

Spannzange / *collet* ER20 DIN6499
 Spannbereich / *clamping range*: 1,0 - 13,0

Gewindebohrzange / *tapping collet*
 ET-1-20 M2-M6

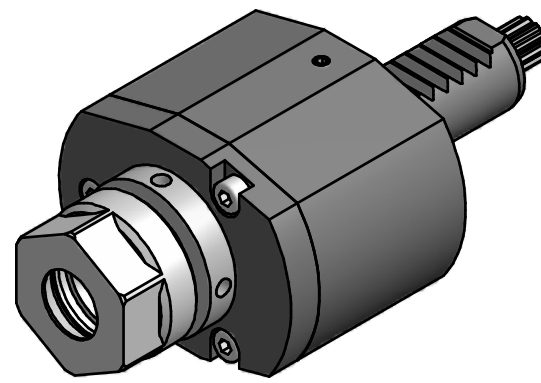
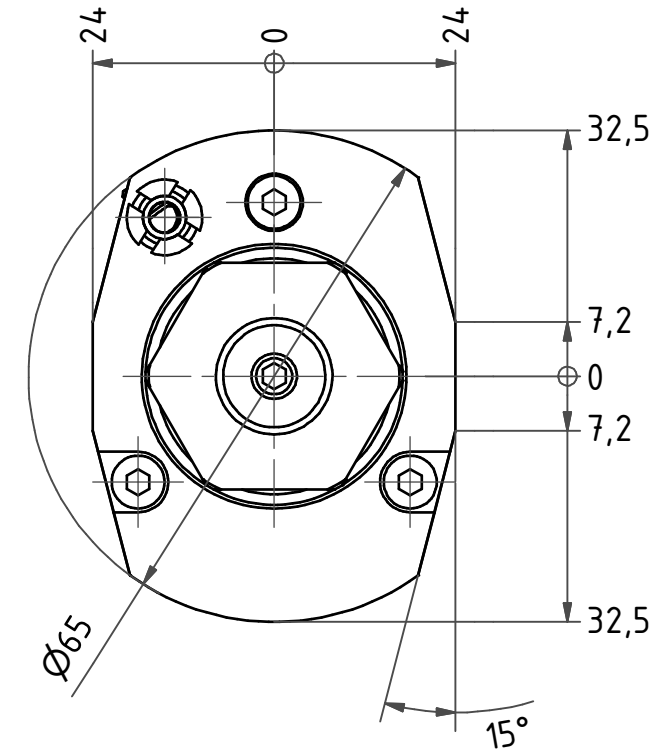
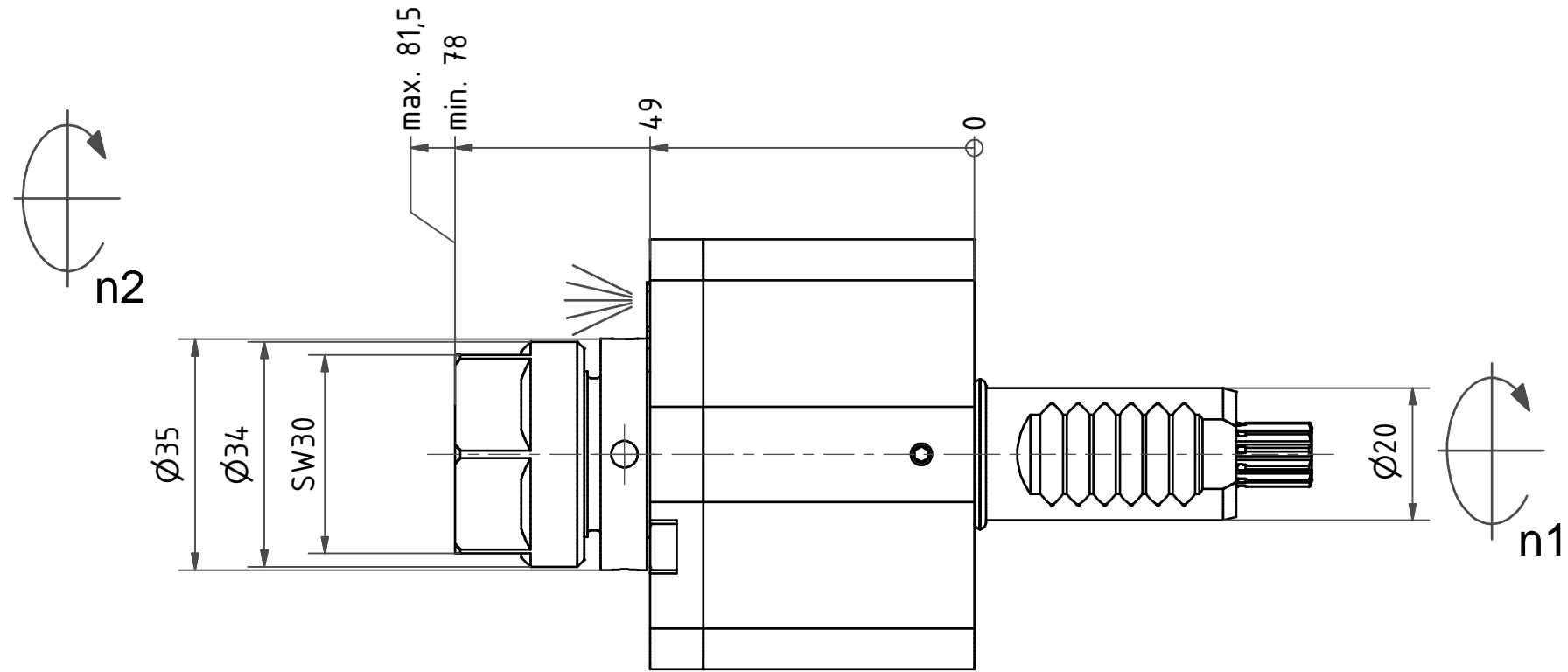

 Hakenschlüssel
 mit Zapfen
*Hook wrench
 with fixed pin*
 DIN1810 B 34x36

Copyright **EWS Tool Technologies**
 Weitergabe und Vervielfältigung dieser Unterlage,
 Verwertung und Mitteilung ihres Inhalts nicht
 gestattet, soweit nicht ausdrücklich zugestanden.
 Zuwiderhandlungen verpflichten zu Schadenersatz.

Bemerkung - <i>Note</i>	Technische Daten - <i>technical data</i> M1 / M2 = 10 / 10 Nm n1 / n2 = 8000 / 8000 1/min i (N1:N2) = 1:1	Benennung - <i>Title</i> Axial Bohr und Fräskopf <i>Axial drilling and milling head</i>	name	date	Technische Änderungen vorbehalten! <i>Subject to technical modifications!</i>	 DIN A3	
			drawing	Theiss			21.01.2008
			 EWS Weigete GmbH & Co. KG Maybachstr. 1 D-73066 Uhingen Tel. +49(0)7161/93040-100		MNR: 100110	IDENT: D-EWS-002835 B	Blatt - <i>page</i> 1 (1)