

Spannzange / collet ER20 DIN6499  
 Spannbereich / clamping range: 1,0 - 13,0

Gewindebohrzange / tapping collet  
 ET-1-20 M2-M6

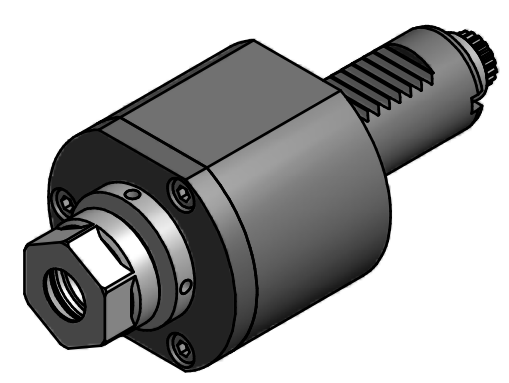

Hakenschlüssel  
 mit Zapfen  
 Hook wrench  
 with fixed pin  
 DIN1810 B 40x42

Copyright **EWS Tool Technologies**  
 Weitergabe und Vervielfaeltigung dieser Unterlage,  
 Verwertung und Mitteilung ihres Inhalts nicht  
 gestattet, soweit nicht ausdrecklich zugestanden.  
 Zuwiderhandlungen verpflichten zu Schadenersatz.

Bemerkung - Note	Technische Daten - technical data M1 / M2= 25 /25 Nm n1 / n2= 8000 /8000 1/min i (N1:N2) = 1:1	Benennung - Title <b>Axial Bohr und Fräskopf</b> <i>Axial drilling and milling head</i>	<table border="1"> <tr> <th>name</th> <th>date</th> </tr> <tr> <td>CAD</td> <td>19.02.2007</td> </tr> </table>	name	date	CAD	19.02.2007	Technische Aenderungen vorbehalten! Subject to technical modifications! Nr. <b>40.3020CTX</b>	 DIN A3
name	date								
CAD	19.02.2007								
			 EWS Weigete GmbH & Co. KG Maybachstr. 1 D-73066 Uhingen Tel. +49(0)7161/93040-100	MNR: 100521 IDENT: D-EWS-003569 A	Blatt - page 05 (199)				