

Spannzange / collet ER25 DIN6499
 Spannbereich / clamping range: 1,0 - 16,0

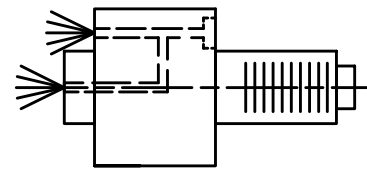

Innen- und Aussenkuehlung / Inside and outside coolant supply
 Kein Trockenlauf / No dry run
 Kuehlmittelfiltrierung 50μ / coolant filtration 50μ

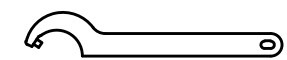
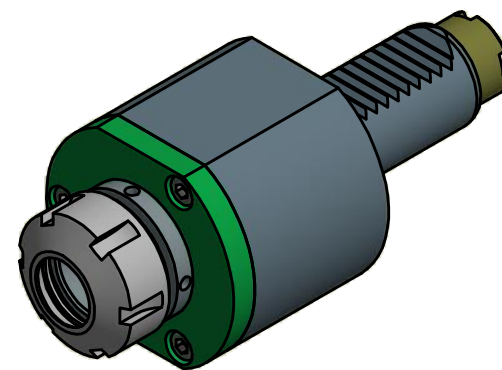

Hakenschlüssel
 mit Zapfen
 Hook wrench
 with fixed pin
 DIN1810 B 40x42

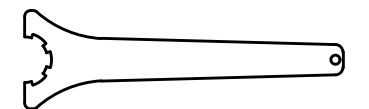

Spannzangenschlüssel
 Clamping wrench
 225

Copyright **EWS Tool Technologies**
 Weitergabe und Vervielfaeltigung dieser Unterlage,
 Verwertung und Mitteilung ihres Inhalts nicht
 gestattet, soweit nicht ausdrecklich zugestanden.
 Zuwiderhandlungen verpflichten zu Schadenersatz.

Bemerkung - Note
 Nicht ohne Kuehlmittel betreiben!
 Not for use without coolant-fluid!

Technische Daten - technical data
 Weight = 1.961 [kg]
 Torque max. (M1/M2) = 25 / 25 [Nm]
 Speed max. (n1/n2) = 8000 / 8000 [1/min]
 Gear ratio (i)=n1:n2 = 1:1
 Pressure (pmax) = 25 [bar]

Benennung - Title
 Axial Bohr und Fräskopf
 Axial drilling and milling head

EWS Tool Technologies
 EWS Weigle GmbH & Co. KG
 Maybachstr. 1
 D-73066 UHINGEN
 www.ews-tools.de
 Nr. - No.
 40.3025LB10IK

Technische Aenderungen vorbehalten!
 Subject to technical modifications!
 IDENT: DEWS082654

REV: -/C
 MNR.
 100543

