

Spannzange / collet ER25 DIN6499
 Spannbereich / clamping range: 1,0 - 16,0

Gewindebohrzange / tapping collet
 ET-1-25 M3-M10

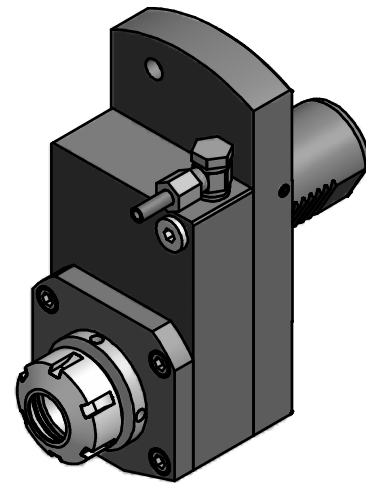

Hakenschlüssel
 mit Zapfen
 Hook wrench
 with fixed pin
 DIN1810 B 45x50

Spannzangenschlüssel
 Clamping wrench
 225

Copyright **EWS Tool Technologies**
 Weitergabe und Vervielfaeltigung dieser Unterlage,
 Verwertung und Mitteilung ihres Inhalts nicht
 gestattet, soweit nicht ausdruuecklich zugestanden.
 Zuwiderhandlungen verpflichten zu Schadenersatz.

Bemerkung - Note	Technische Daten - technical data M1 / M2 = 50 / 50 Nm n1 / n2 = 6000 / 6000 1/min i (N1:N2) = 1:1	Benennung - Title Axial Bohr u. Fräskopf achsversetzt Ax. drill. and mill. head offset	<table border="1"> <tr> <td>name</td> <td>date</td> </tr> <tr> <td>drawing</td> <td>15.03.2007</td> </tr> </table>	name	date	drawing	15.03.2007	Technische Aenderungen vorbehalten! Subject to technical modifications! Nr. 50.4025SQT10R File: 50.4025SQT10_OUT.idw	 DIN A3 Blatt - page 1 (1)
name	date								
drawing	15.03.2007								