

Spannzange / *collet* ER25 DIN6499
 Spannbereich / *clamping range*: 1,0 - 16,0

Gewindebohrzange / *tapping collet*
 ET-1-25 M3-M10

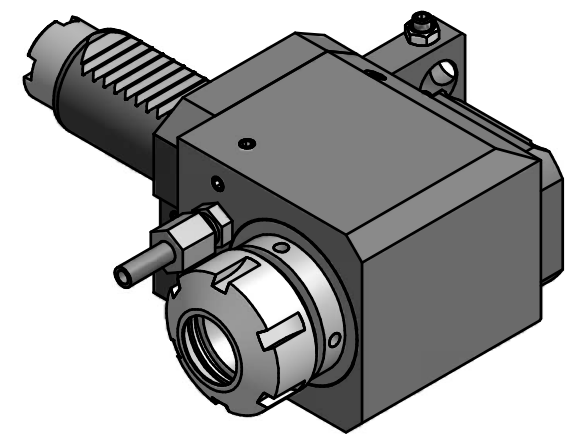
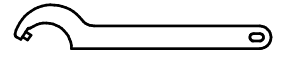
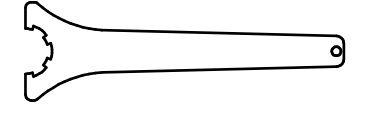

-  Hakenschlüssel mit Zapfen
Hook wrench with fixed pin
DIN1810 B 40x42
-  Spannzangenschlüssel
Clamping wrench
225

Copyright **EWS Tool Technologies**
 Weitergabe und Vervielfaeltigung dieser Unterlage,
 Verwertung und Mitteilung ihres Inhalts nicht
 gestattet, soweit nicht ausdrecklich zugestanden.
 Zuwiderhandlungen verpflichten zu Schadenersatz.

Bemerkung - <i>Note</i> 	Technische Daten - <i>technical data</i> M1 / M2 = 25 / 25 Nm n1 / n2 = 8000 / 8000 1/min i (N1:N2) = 1:1	Benennung - <i>Title</i> Radial Bohr und Fräskopf <i>Radial drilling and milling head</i>	<table border="1"> <tr> <th>name</th> <th>date</th> </tr> <tr> <td>drawing</td> <td>08.03.2007</td> </tr> </table>	name	date	drawing	08.03.2007	Technische Aenderungen vorbehalten! <i>Subject to technical modifications!</i> Nr. 60.3025LB10LGL MNR: 100730 IDENT: D-EWS-009220 A Blatt - page 1 (1)	 DIN A3
name	date								
drawing	08.03.2007								