

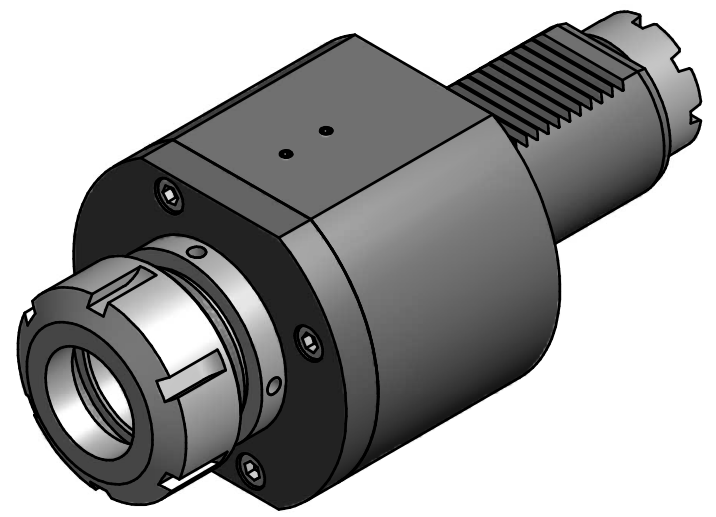



Spannzange / collet ER40 DIN6499  
 Spannbereich / clamping range: 3,0 - 26,0

Gewindebohrzange / tapping collet  
 ET-1-40 M6-M16



Copyright **EWS Tool Technologies**  
 Weitergabe und Vervielfaeltigung dieser Unterlage,  
 Verwertung und Mitteilung ihres Inhalts nicht  
 gestattet, soweit nicht ausdruuecklich zugestanden.  
 Zuwiderhandlungen verpflichten zu Schadenersatz.

Bemerkung - Note	Technische Daten - technical data Weight = 5.887 [kg] Torque max. (M1/M2) = 100 / 100 [Nm] Speed max. (n1/n2) = 4.000 / 4.000 [1/min] Gear ratio (i)=n1:n2 = 1:1	Benennung - Title <b>Axial Bohr und Fräskopf</b> <i>Axial drilling and milling head</i>	 EWS Weigle GmbH & Co. KG Maybachstr. 1 D-73066 Utingen www.ews-tools.de	Technische Aenderungen vorbehalten! Subject to technical modifications! IDENT: D-EWS-006344	 REV: -/- MNR. <b>108971</b>	
			Nr. - No. <b>40.5040TOEM</b>			