

Spannzange / collet ER25 DIN6499  
 Spannbereich / clamping range: 1,0 - 16,0

Gewindebohrzange / tapping collet  
 ET-1-25 M3-M10

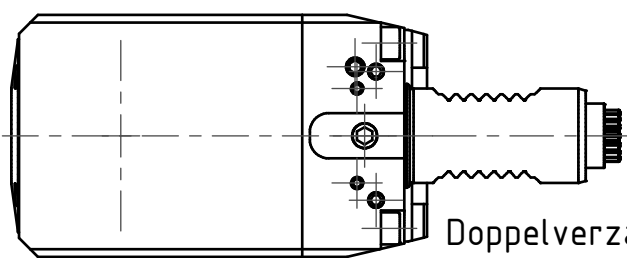

Doppelverzahnung Lizenz Traub  
 double tooth system licence Traub

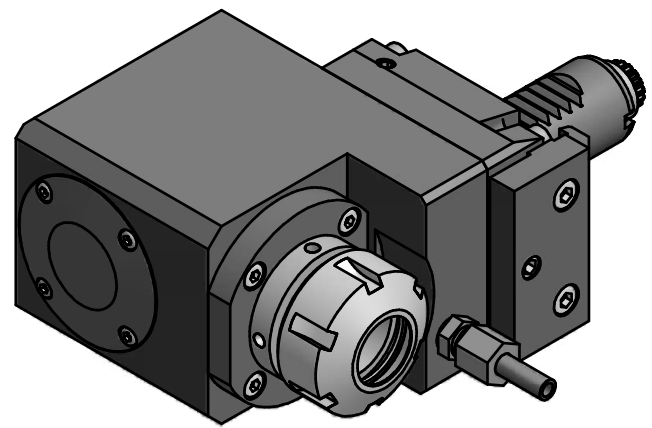

Hakenschlüssel  
 mit Zapfen  
 Hook wrench  
 with fixed pin  
 DIN1810 B 40x42

Spannzangenschlüssel  
 Clamping wrench  
 225

Copyright **EWS Tool Technologies**  
 Weitergabe und Vervielfaeltigung dieser Unterlage,  
 Verwertung und Mitteilung ihres Inhalts nicht  
 gestattet, soweit nicht ausdrecklich zugestanden.  
 Zuwiderhandlungen verpflichten zu Schadenersatz.

Bemerkung - Note	Technische Daten - technical data M1 / M2= 25 /25 Nm n1 / n2 = 8000 /8000 1/min i (N1:N2) = 1:1	Benennung - Title <b>Radial Bohr und Fräskopf. zurückges</b> <b>Radial drill. and mill. head offset</b>	<table border="1"> <tr> <th>name</th> <th>date</th> </tr> <tr> <td>drawing</td> <td>28.02.2007</td> </tr> </table>	name	date	drawing	28.02.2007	Technische Aenderungen vorbehalten! Subject to technical modifications! Nr. <b>80.2525E332RL</b> DIN A3 MNR: 109617 IDENT: D-EWS-006811 A Blatt - page 1 (1)
name	date							
drawing	28.02.2007							