

Spannzange / collet ER20 DIN6499
 Spannbereich / clamping range: 1,0 - 13,0

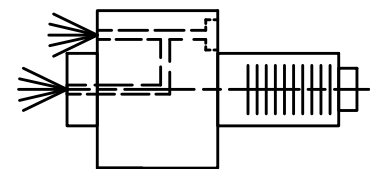

Innen- und Aussenkuehlung / Inside and outside coolant supply
 Kein Trockenlauf / No dry run
 Kuehlmittelfiltrierung <math>< 50\mu</math> / coolant filtration <math>< 50\mu</math>

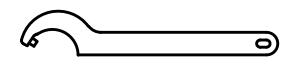
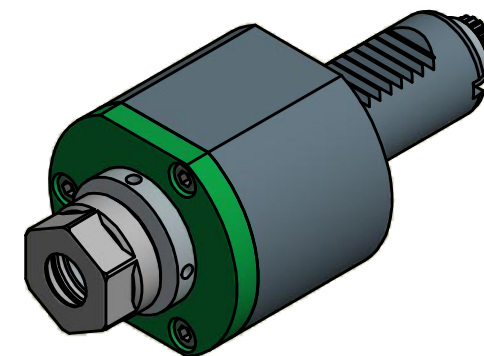

Hakenschlüssel
 mit Zapfen
 Hook wrench
 with fixed pin
 DIN1810 B 40x42

Copyright **EWS Tool Technologies**
 Weitergabe und Vervielfaeltigung dieser Unterlage,
 Verwertung und Mitteilung ihres Inhalts nicht
 gestattet, soweit nicht ausdrecklich zugestanden.
 Zuwiderhandlungen verpflichten zu Schadenersatz.

<p>Bemerkung - Note</p> <p>Nicht ohne Kuehlmittel betreiben! <i>Not for use without coolant-fluid!</i></p>	<p>Technische Daten - technical data</p> <p>Weight = 1.918 [kg] Torque max. (M1/M2) = 25 / 25 [Nm] Speed max. (n1/n2) = 8000 / 8000 [1/min] Gear ratio (i)=n1:n2 = 1:1 Pressure (pmax) = 25 [bar]</p>	<p>Benennung - Title</p> <p>Axial Bohr und Fräskopf <i>Axial drilling and milling head</i></p>	<p>EWS Tool Technologies <small>EWS Weigle GmbH & Co. KG Maybachstr. 1 D-73066 Uehingen www.ews-tools.de</small></p> <p>Nr. - No. 40.3020CTXIK</p>	<p>Technische Aenderungen vorbehalten! <i>Subject to technical modifications!</i></p> <p>IDENT: DEWS082577</p>	<p> REV: -/B MNR. 110560</p>	<p>QR</p>
---	---	---	---	---	---	------------------