

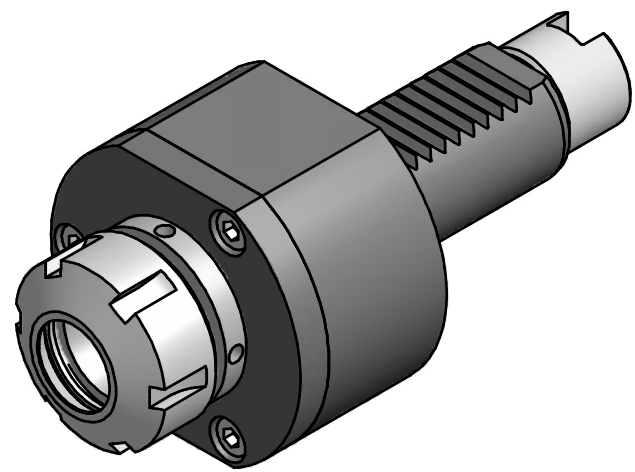

Spannzange / collet ER25 DIN6499
 Spannbereich / clamping range: 1,0 - 16,0

Gewindebohrzange / tapping collet
 ET-1-25 M3-M10



Hakenschlüssel
 mit Zapfen
 Hook wrench
 with fixed pin
 DIN1810 B 40x42



Spannzangenschlüssel
 Clamping wrench
 225

Copyright **EWS Tool Technologies**
 Weitergabe und Vervielfaeltigung dieser Unterlage,
 Verwertung und Mitteilung ihres Inhalts nicht
 gestattet, soweit nicht ausdrecklich zugestanden.
 Zuwiderhandlungen verpflichten zu Schadenersatz.

Bemerkung - Note	Technische Daten - technical data $M1 / M2 = 25 / 25 \text{ Nm}$ $n1 / n2 = 8000 / 8000 \text{ 1/min}$ $i (N1:N2) = 1:1$	Benennung - Title Axial Bohr und Fräskopf <i>Axial drilling and milling head</i>	<table border="1"> <tr> <th>name</th> <th>date</th> </tr> <tr> <td>drawing CAD</td> <td>05.03.2007</td> </tr> </table>	name	date	drawing CAD	05.03.2007	Technische Aenderungen vorbehalten! Subject to technical modifications! Nr. 40.3025KG300	 DIN A3
name	date								
drawing CAD	05.03.2007								
			 EWS Weigete GmbH & Co. KG Maybachstr. 1 D-73066 Uhingen Tel. +49(0)7161/93040-100	MNR: 111120 IDENT: D-EWS-008175 - Blatt: 01.02 Page: 1 (1)					