

Spannzange / collet ER40 DIN6499
 Spannbereich / clamping range: 3,0 - 26,0

Gewindebohrzange / tapping collet
 ET-1-40 M6-M16

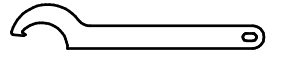

Hakenschlüssel
 mit Nase
 Hook wrench with
 nose end

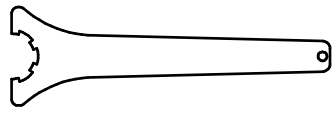

Spannzangenschlüssel
 Clamping wrench
 240

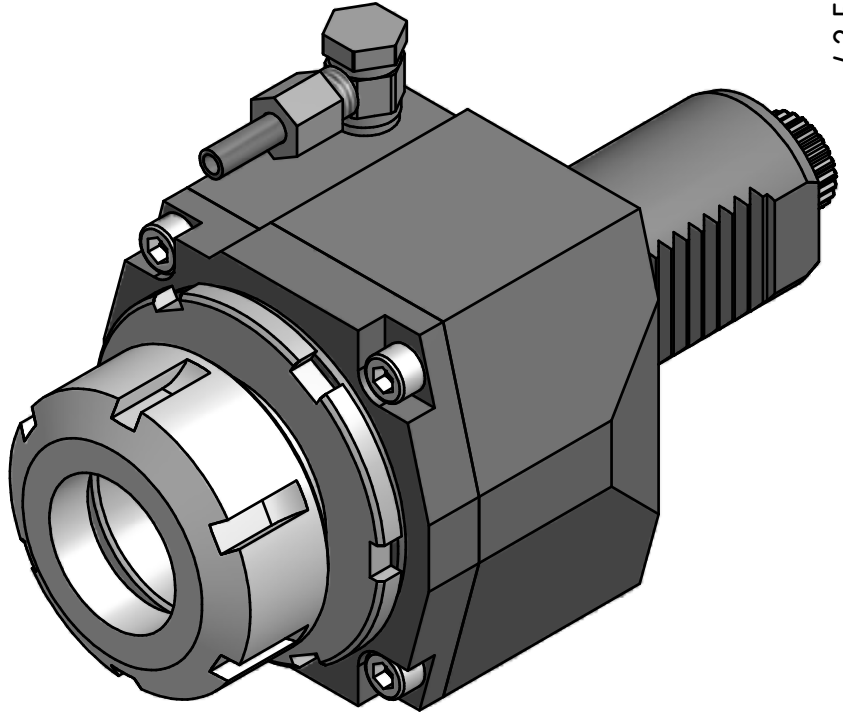

Copyright **EWS Tool Technologies**
 Weitergabe und Vervielfaeltigung dieser Unterlage,
 Verwertung und Mitteilung ihres Inhalts nicht
 gestattet, soweit nicht ausdrecklich zugestanden.
 Zuwiderhandlungen verpflichten zu Schadenersatz.

Bemerkung - Note	Technische Daten - technical data M1 / M2= 50 /50 Nm n1 / n2 = 6000 /6000 1/min i (N1:N2) = 1:1	Benennung - Title Axial Bohr und Fräskopf <i>Axial drilling and milling head</i>	name	date	Technische Aenderungen vorbehalten! Subject to technical modifications!	
			drawing	03.02.2009		
			Weigle GmbH & Co. KG Maybachstr. 1 D-73066 Utingen Tel. +49(0)7161/93040-10		File: D-EWS-004477A.idw	Blatt - page 1 (1)