

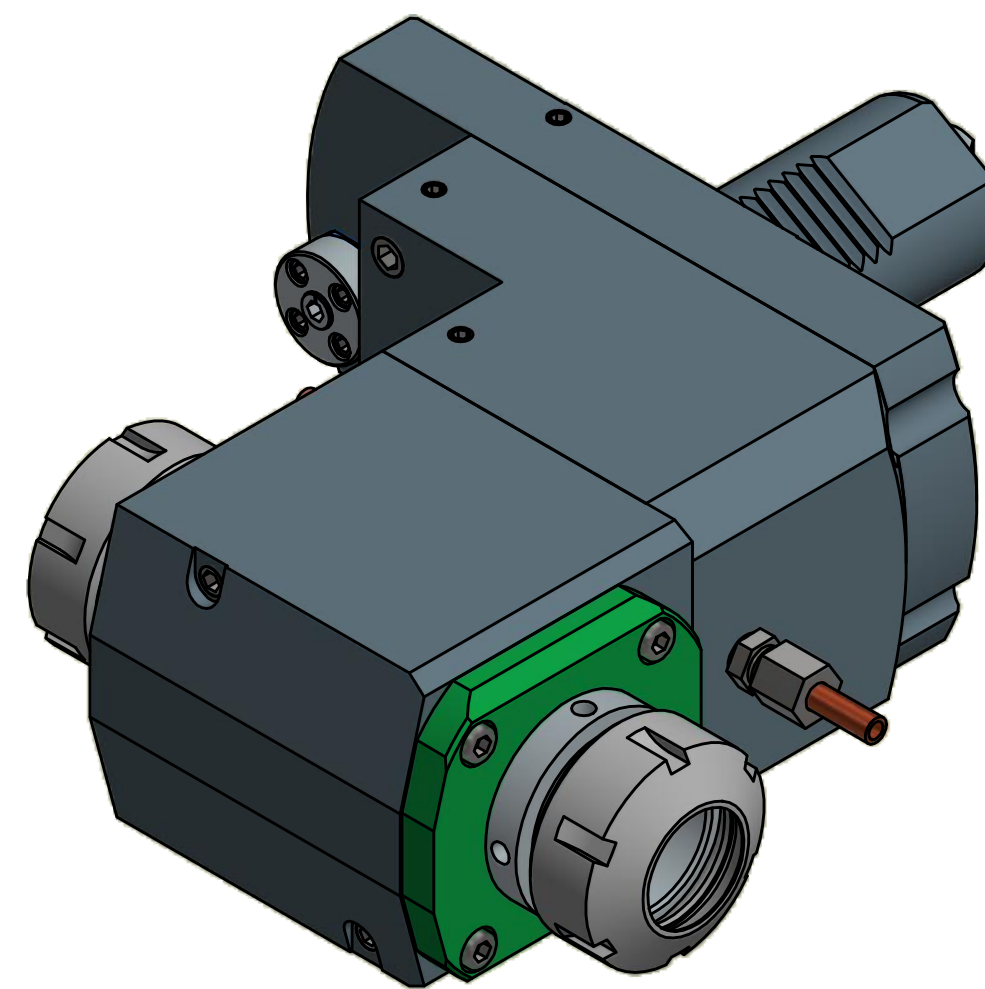

Spannzange / collet ER32 DIN6499  
Spannbereich / clamping range: 2,0 - 20,0

Gewindebohrzange / tapping collet  
ET-1-32 M5-M12



Copyright **EWS Tool Technologies**  
Weitergabe und Vervielfältigung dieser Unterlage,  
Verwertung und Mitteilung ihres Inhalts nicht  
gestattet, soweit nicht ausdrücklich zugestanden.  
Zuwerhandlungen verpflichten zu Schadenersatz.

Bemerkung - Note Technische Daten - technical data Weight = 9,966 [kg] Torque max. (M1/M2) = 50 / 50   50 [Nm] Speed max. (n1/n2) = 6000 / 6000   6000 [1/min] Gear ratio (i)=n1:n2 = 1:1   1:1	Benennung - Title <b>Radial Bohr und Fräskopf, zurückges</b> <i>Radial drill. and mill. head offset</i>	 EWS Weigle GmbH & Co. KG Maybachstr. 1 D-73066 Ulm/ingen www.ews-tool.de Technische Änderungen vorbehalten! Subject to technical modifications! IDENT: DEWS099158 Nr. - No. 80.4032DSQT15L MNR. 114470	
--	---	--	---