

Spannzange / collet ER25 DIN6499
 Spannbereich / clamping range: 1,0 - 16,0

Gewindebohrzange / tapping collet
 ET-1-25 M3-M10

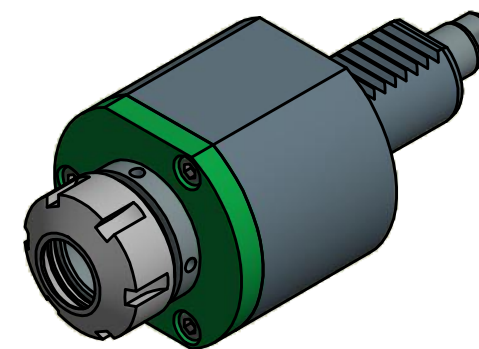

 Hakenschlüssel
 mit Zapfen
 Hook wrench
 with fixed pin
 DIN1810 B 40x42

 Spannzangenschlüssel
 Clamping wrench
 225

Copyright **EWS Tool Technologies**
 Weitergabe und Vervielfaeltigung dieser Unterlage,
 Verwertung und Mitteilung ihres Inhalts nicht
 gestattet, soweit nicht ausdrecklich zugestanden.
 Zuwiderhandlungen verpflichten zu Schadenersatz.

Bemerkung - Note

Technische Daten - technical data

Weight = 1.908 [kg]
 Torque max. (M1/M2) = 25 / 25 [Nm]
 Speed max. (n1/n2) = 8000 / 8000 [1/min]
 Gear ratio (i)=n1:n2 = 1:1

Benennung - Title

Axial Bohr und Fräskopf
 Axial drilling and milling head

EWS
 Tool Technologies

EWS Weigle GmbH & Co. KG
 Maybachstr. 1
 D-73066 UHINGEN
 www.ews-tools.de

Technische Aenderungen vorbehalten!
 Subject to technical modifications!

IDENT: DEWS117420

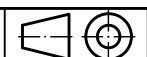

REV: -/B

Nr. - No.

40.3025HD1809

MNR.

115815

QR