

6 | 5 | 4 | 3 | 2 | 1

D

D

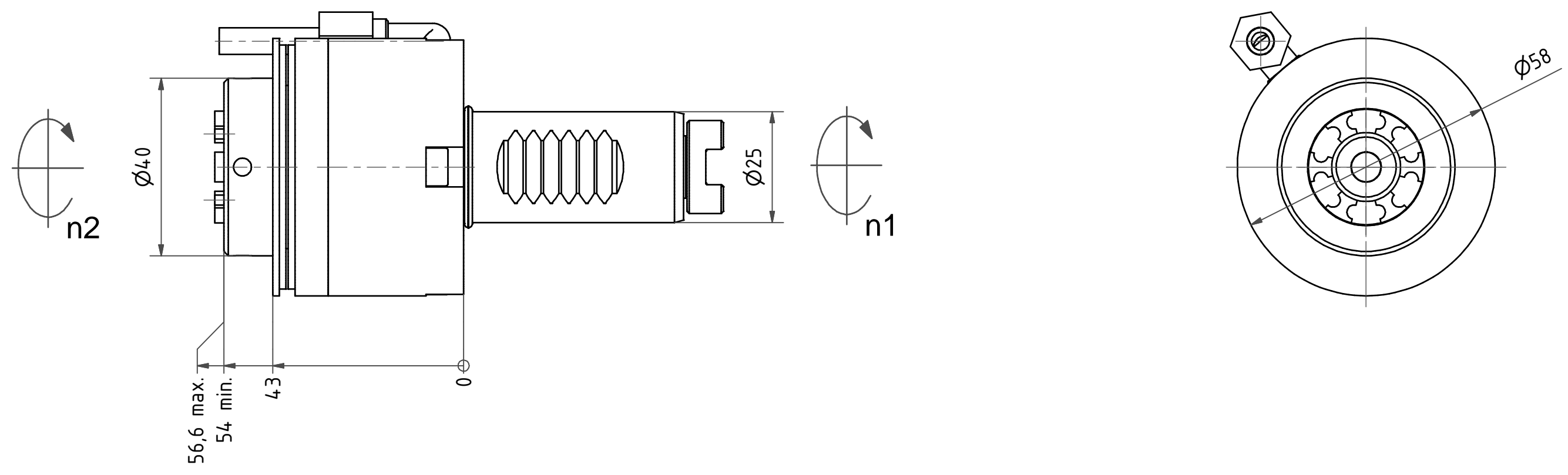

Spannzange / collet ER20 DIN6499
Spannbereich / clamping range: 1,0 - 13,0

Gewindebohrzange / tapping collet
ET-1-20 M2-M6

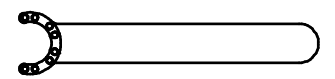

Spannzangenschlüssel für
innenliegende Mutter
Clamping wrench for
internal collet
EA 20 K

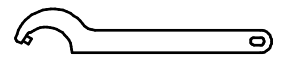

Hakenschlüssel
mit Zapfen
Hook wrench
with fixed pin
DIN1810 B 40x42

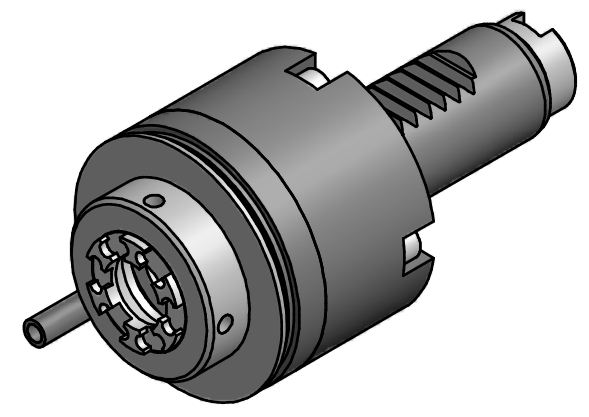

Copyright **EWS Tool Technologies**
Weitergabe und Vervielfältigung dieser Unterlage,
Verwertung und Mitteilung ihres Inhalts nicht
gestattet, soweit nicht ausdrücklich zugestanden.
Zuwendungen verpflichten zu Schadenersatz.

A

A

Bemerkung - Note	Technische Daten - technical data M1 / M2= 16 /16 Nm n1 / n2 = 8000 /8000 1/min i (N1:N2) = 1:1	Benennung - Title Axial Bohr und Fräskopf <i>Axial drilling and milling head</i>	<table border="1"> <tr> <th>name</th> <th>date</th> </tr> <tr> <td>drawing</td> <td>28.02.2007</td> </tr> </table>	name	date	drawing	28.02.2007	Technische Aenderungen vorbehalten! Subject to technical modifications! Nr. 40.2520G200BIM	 DIN A3
name	date								
drawing	28.02.2007								
			 EWS Weigete GmbH & Co. KG Maybachstr. 1 D-73066 Uhingen Tel. +49(0)7161/93040-100	MNR: 119311 IDENT: D-EWS-007001 A	Blatt - page 1 (1)				

6 | 5 | 4 | 3 | 2 | 1