

Spannzange / collet ER40 DIN6499
 Spannbereich / clamping range: 3,0 - 26,0

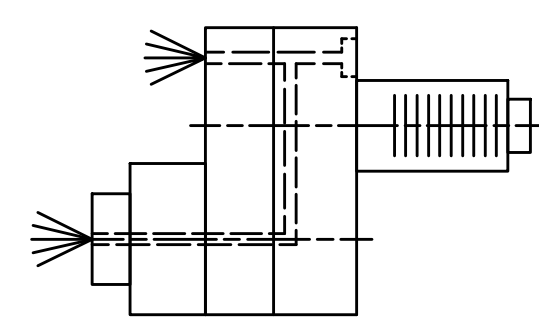

Innen- und Aussenkuehlung
 Inside and outside coolant supply

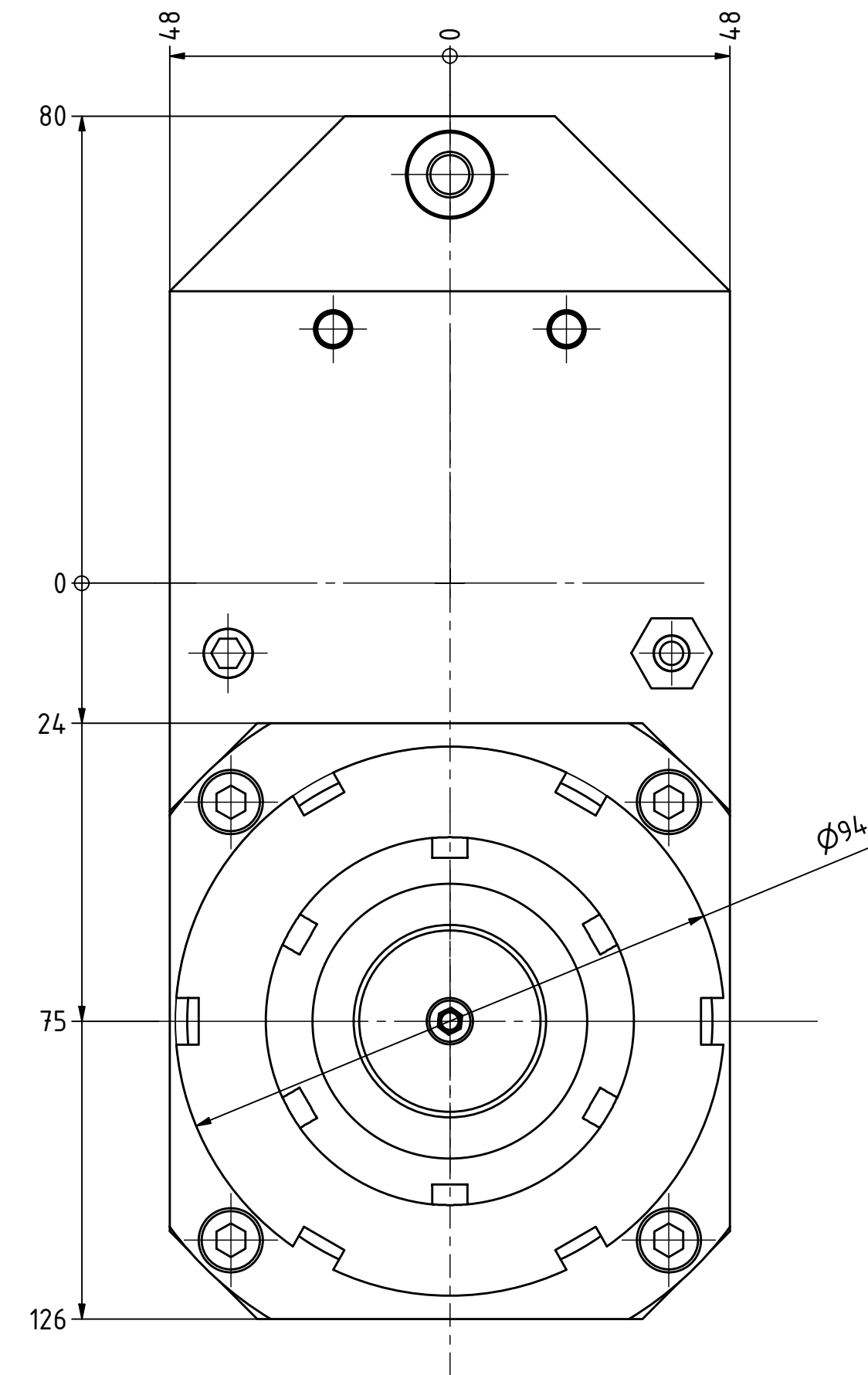
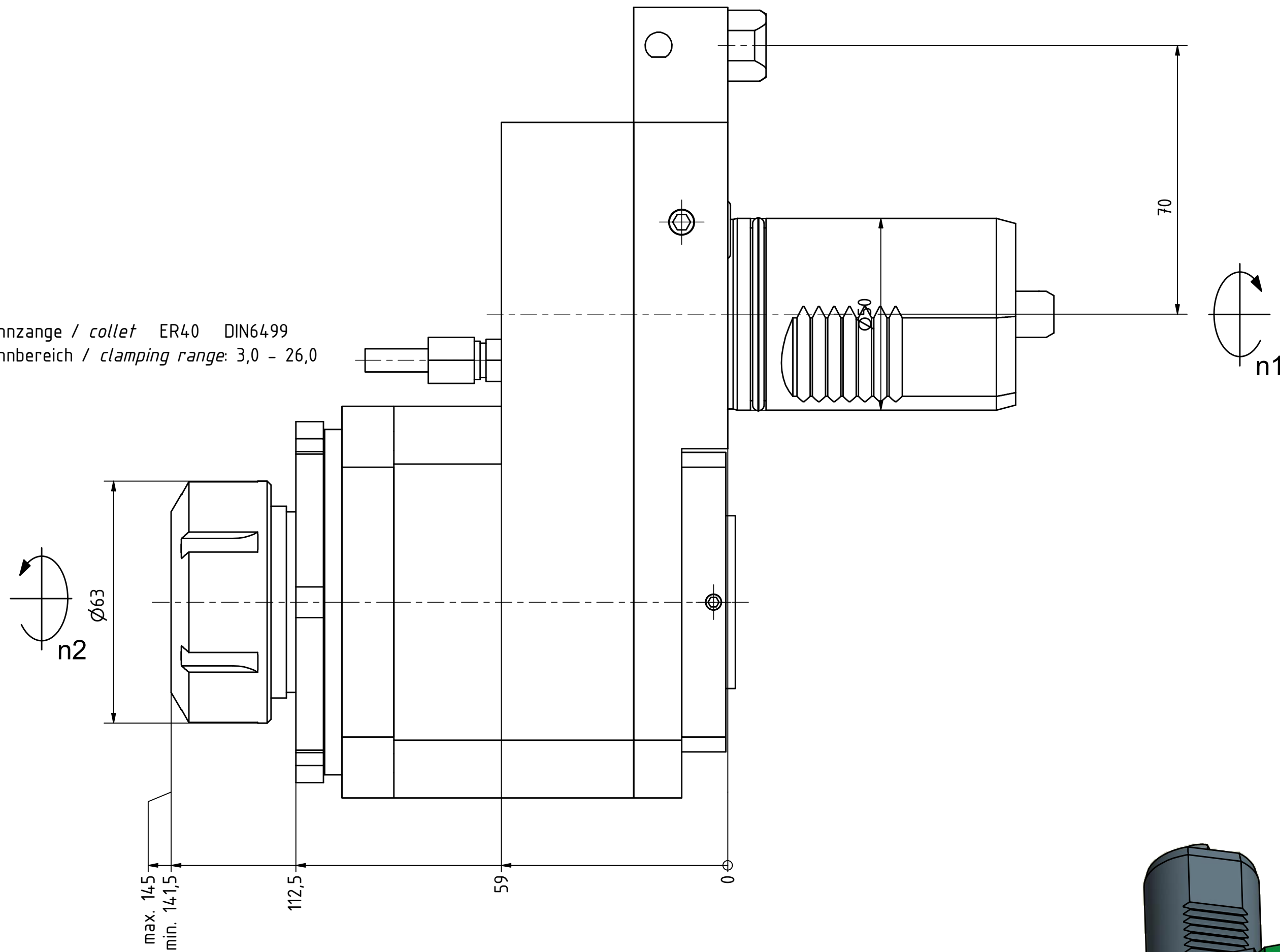
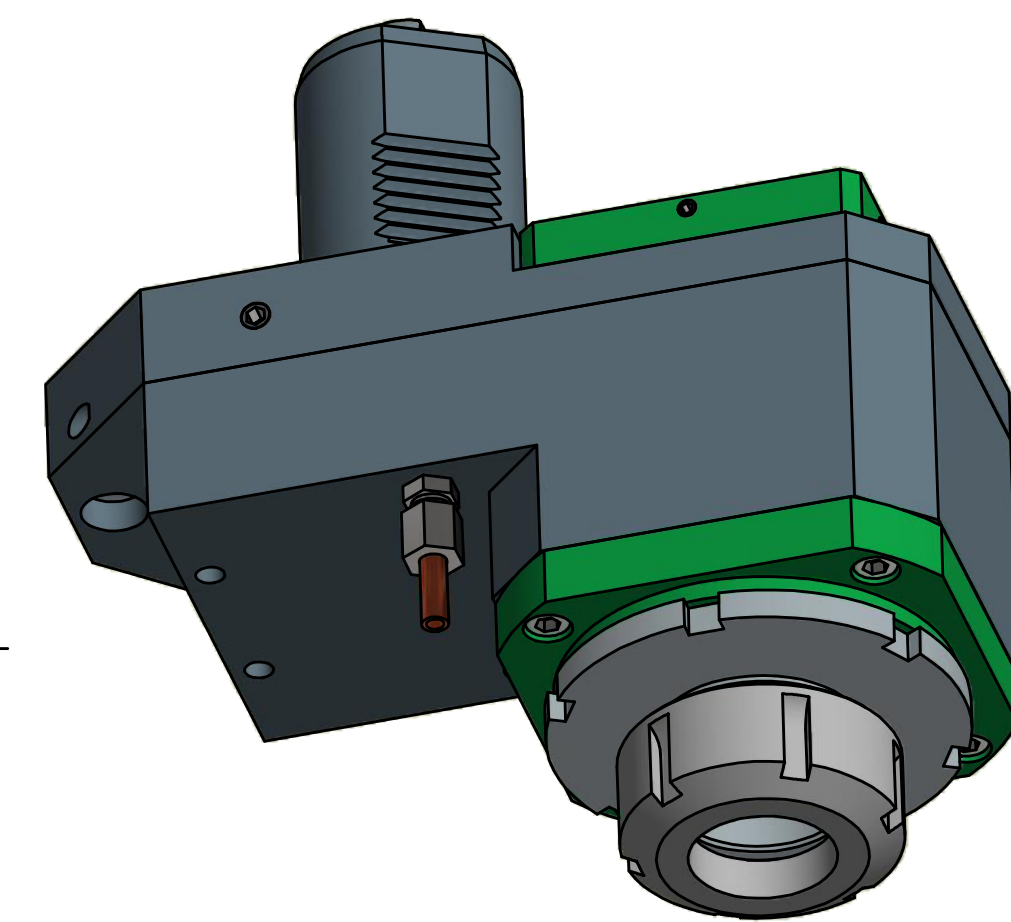
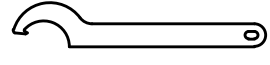

 Hakenschlüssel
 mit Nase
 Hook wrench with
 nose end
 DIN1810 A 110x115

 Spannzangenschlüssel
 Clamping wrench
 240

Copyright **EWS Tool Technologies**
 Weitergabe und Vervielfaeltigung dieser Unterlage,
 Verwertung und Mitteilung ihres Inhalts nicht
 gestattet, soweit nicht ausdrecklich zugestanden.
 Zuwiderhandlungen verpflichten zu Schadenersatz.

<p>Bemerkung - Note Nicht ohne Kuehlmittel betreiben! <i>Not for use without coolant-fluid!</i></p>	<p>Technische Daten - technical data Weight = 11.466 [kg] Torque max. (M1/M2)= 100 / 100 [Nm] Speed max. (n1/n2) = 6000 / 6000 [1/min] Gear ratio (i)=n1:n2= 1:1 Pressure (pmax) = 70 [bar]</p>	<p>Benennung - Title Axial Bohr u. Fräskopf achsversetzt <i>Ax. drill. and mill. head offset</i></p>	<p>EWS EWS Weigle GmbH & Co. KG Maybachstr. 1 D-73066 Uhlingen www.ews-tools.de</p>	<p>Technische Aenderungen vorbehalten! Subject to technical modifications! IDENT: D-EWS-014294</p>	<p>Nr. - No. 50.5040SQT28RIK</p> <p>REV: -/- MNR. 119972</p>
--	---	---	---	--	---

