

Spannzange / collet ER32 DIN6499
Spannbereich / clamping range: 2,0 - 20,0

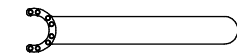

Spannzangenschlüssel für
innenliegende Mutter
Clamping wrench for
internal collet
EA 32 K

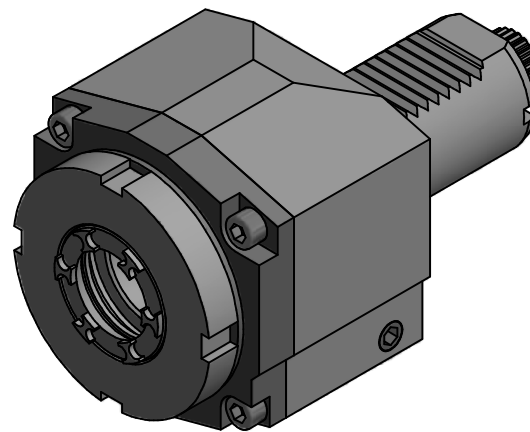
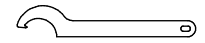

Hakenschlüssel
mit Nase
Hook wrench with
nose end
DIN1810 A 68x75

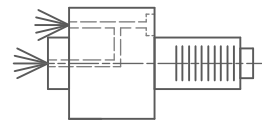

Innen- und Aussenkuehlung / Inside and outside coolant supply
Kein Trockenlauf / No dry run
Kuehlmittelfiltrierung-50µ / coolant filtration-50µ

Copyright **EWS Tool Technologies**
Weitergabe und Vervielfaeltigung dieser Unterlage,
Verwertung und Mitteilung ihres Inhalts nicht
gestattet, soweit nicht ausdruücklich zugestanden.
Zuwaiderhandlungen verpflichten zu Schadenersatz.

<p>Bemerkung - Note</p> <p>Nicht ohne Kuehlmittel betreiben! Not for use without coolant-fluid!</p>	<p>Technische Daten - technical data</p> <p>Weight = 3.567 [kg] Torque max. (M1/M2) = 50 / 50 [Nm] Speed max. (n1/n2) = 6000 / 6000 [1/min] Gear ratio (i)=n1:n2 = 1:1 Pressure (pmax) = 25 [bar]</p>	<p>Benennung - Title</p> <p>Axial Bohr und Fräskopf Axial drilling and milling head</p>	<p>EWS Tool Technologies EWS Weigelt GmbH & Co. KG Maybachstr. 1 D-73066 Uhlingen www.ews-tools.de</p> <p>Nr. - No. 40.4032KCTXIKIM</p>	<p>Technische Aenderungen vorbehalten! Subject to technical modifications!</p> <p>IDENT: DEWS009030 REV: -/C MNR. 122723</p>	<p>QR</p>
---	---	---	---	---	-----------