

Spannzange / Collet ER16 DIN6499
 Spannereich / Clamping range: 1,0 - 10,0

Gewindebohrzange / Tapping Collet
 ET-1-16 M1-M6

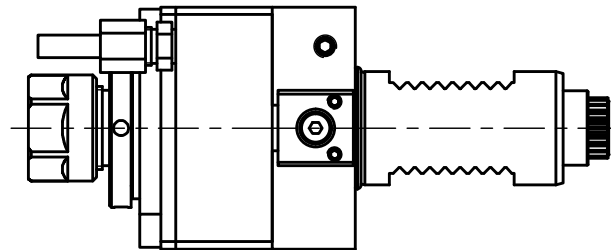

Doppelverzahnung Lizenz Traub
 double tooth system licence Traub

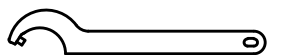
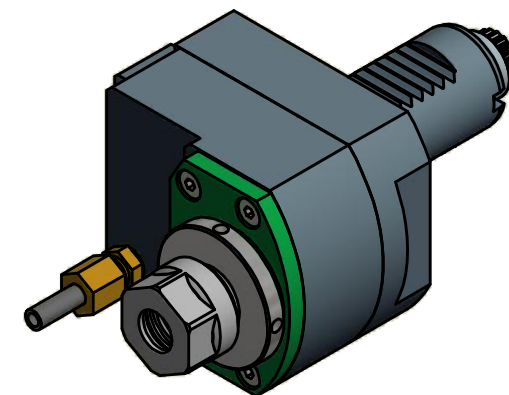

Hakenschlüssel
 mit Zapfen
 Hook wrench
 with fixed pin
 DIN1810 B 40x42

Copyright **EWS Tool Technologies**
 Weitergabe und Vervielfaeltigung dieser Unterlage,
 Verwertung und Mitteilung ihres Inhalts nicht
 gestattet, soweit nicht ausdrecklich zugestanden.
 Zuwiderhandlungen verpflichten zu Schadenersatz.

Bemerkung - Note

Technische Daten - technical data

Weight = 2.364 [kg]
 Torque max. (M1/M2) = 15 / 5 [Nm]
 Speed max. (n1/n2) = 6000 / 18000 [1/min]
 Gear ratio (i)=n1:n2 = 1:3,2

Benennung - Title

Axial Bohr u. Fräskopf achsversetzt
 Ax. drill. and mill. head offset



Nr. - No.

50.3016CTXRLI13

EWS Weigle GmbH & Co. KG
 Maybachstr. 1
 D-73066 UHINGEN
 www.ews-tools.de

Technische Aenderungen vorbehalten!
 Subject to technical modifications!

IDENT: DEWS037722

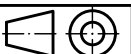

REV: -/B

MNR.

125876

