

Spannzange / collet ER25 DIN6499  
 Spannbereich / clamping range: 1,0 - 16,0

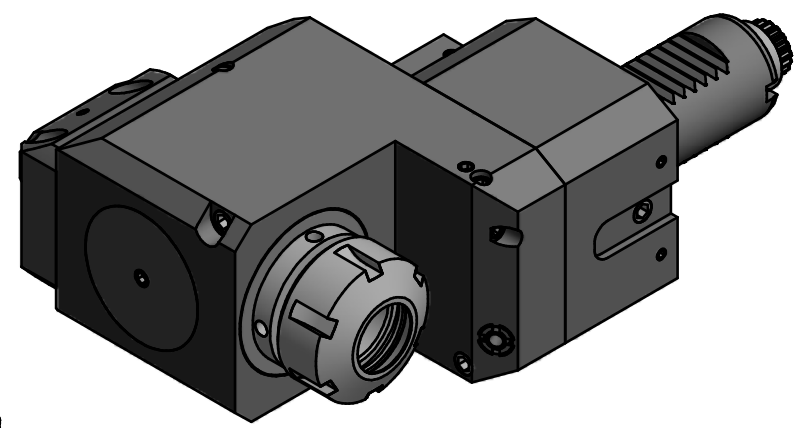

  
 Spannzangenschlüssel  
 Clamping wrench  
 225

  
 Hackenschlüssel  
 mit Zapfen  
 Hook wrench  
 with fixed pin  
 DIN1810 B 40x42

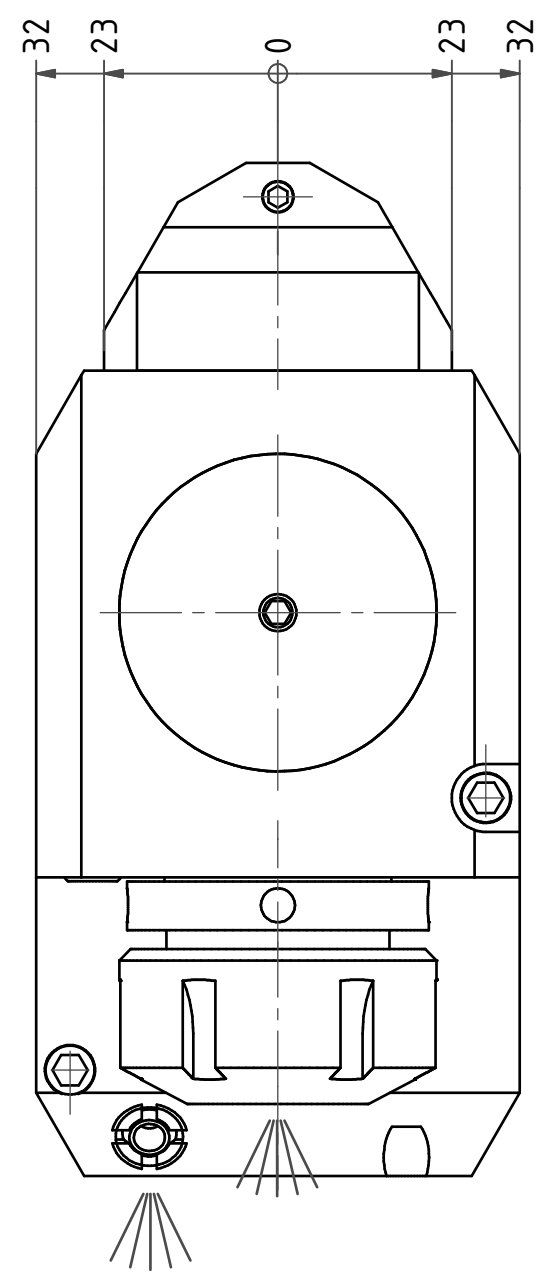
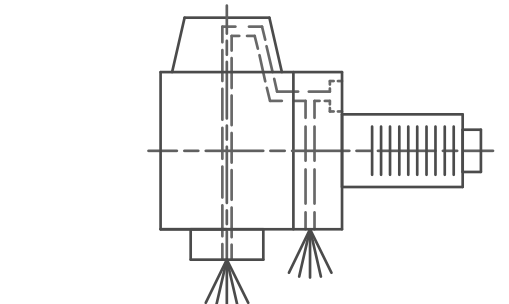

Innen- und Aussenkuehlung / Inside and outside coolant supply  
 Kein Trockenlauf / No dry run  
 Kuehlmittelfiltrierung-50µ / coolant filtration-50µ

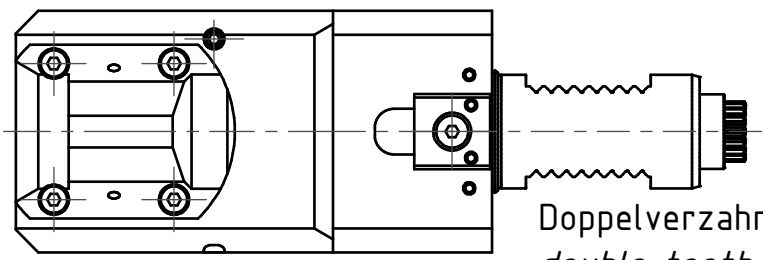

Doppelverzahnung Lizenz Traub  
 double tooth system licence Traub

Copyright **EWS Tool Technologies**  
 Weitergabe und Vervielfaeltigung dieser Unterlage,  
 Verwertung und Mitteilung ihres Inhalts nicht  
 gestattet, soweit nicht ausdrecklich zugestanden.  
 Zuwiderhandlungen verpflichten zu Schadenersatz.

Bemerkung - Note  
 Nicht ohne Kuehlmittel betreiben!  
 Not for use without coolant-fluid!

Technische Daten - technical data	
Weight	= 4.545 [kg]
Torque max. (M1/M2)	= 25 / 25 [Nm]
Speed max. (n1/n2)	= 8000 / 8000 [1/min]
Gear ratio (i)=n1:n2	= 1:1
Pressure (pmax)	= 70 [bar]

Benennung - Title  
**Radial Bohr und Fräskopf, zurückges**  
**Radial drill. and mill. head offset**

**EWS** Tool Technologies  
 EWS Weigle GmbH & Co. KG  
 Maybachstr. 1  
 D-73066 Utingen  
 www.ews-tools.de

Nr. - No.  
**80.3025LCTXRLIK**

Technische Aenderungen vorbehalten! Subject to technical modifications!	
IDENT: D-EWS-004203	REV: A/-
MNR.	<b>126170</b>

