

Spannzange / collet ER32 DIN6499  
 Spannbereich / clamping range: 2,0 - 20,0

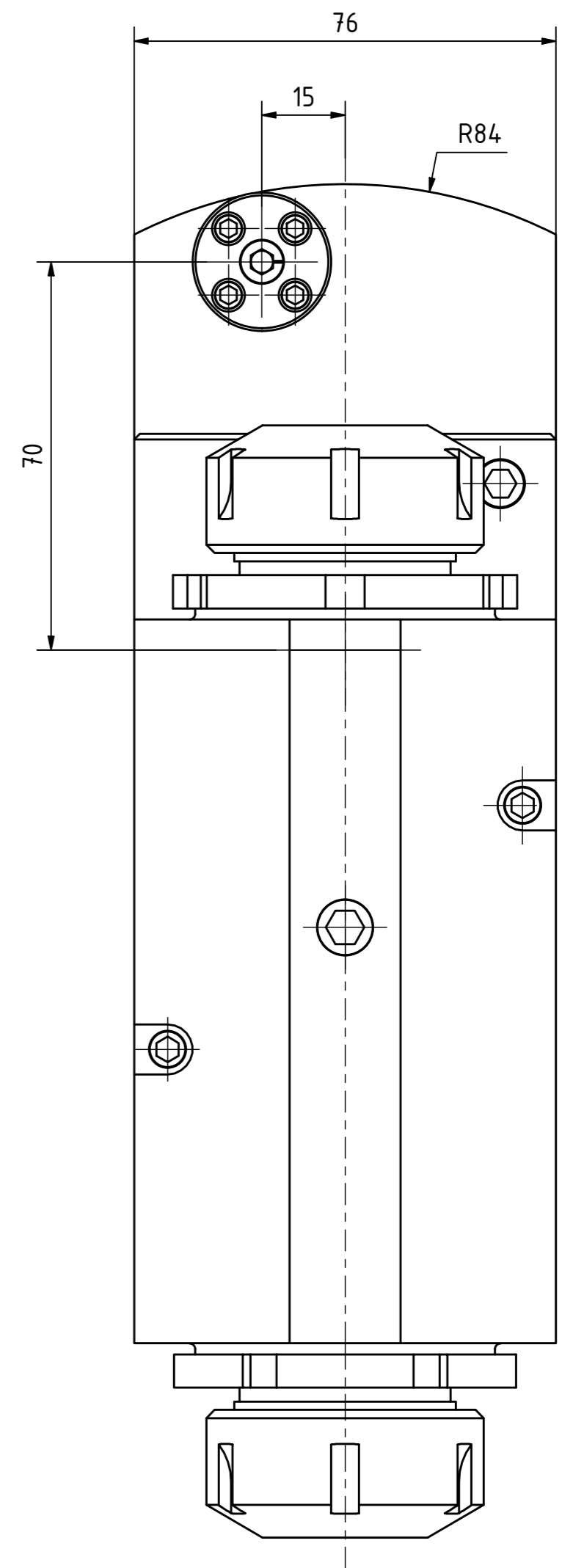

Hakenschlüssel mit Nase  
 Hook wrench with nose end  
 DIN1810 A 58x62

Spannzangenschlüssel  
 Clamping wrench  
 232

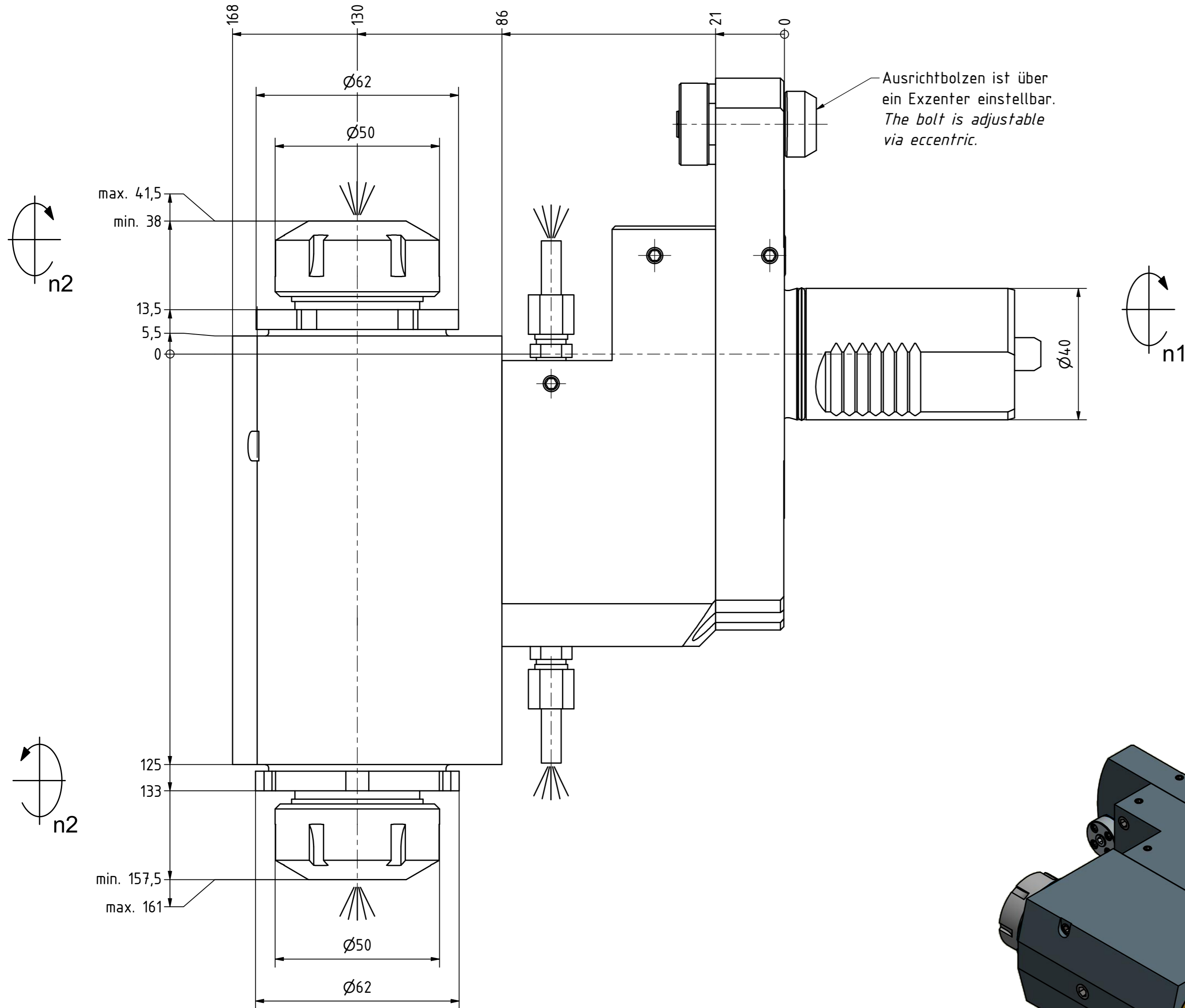
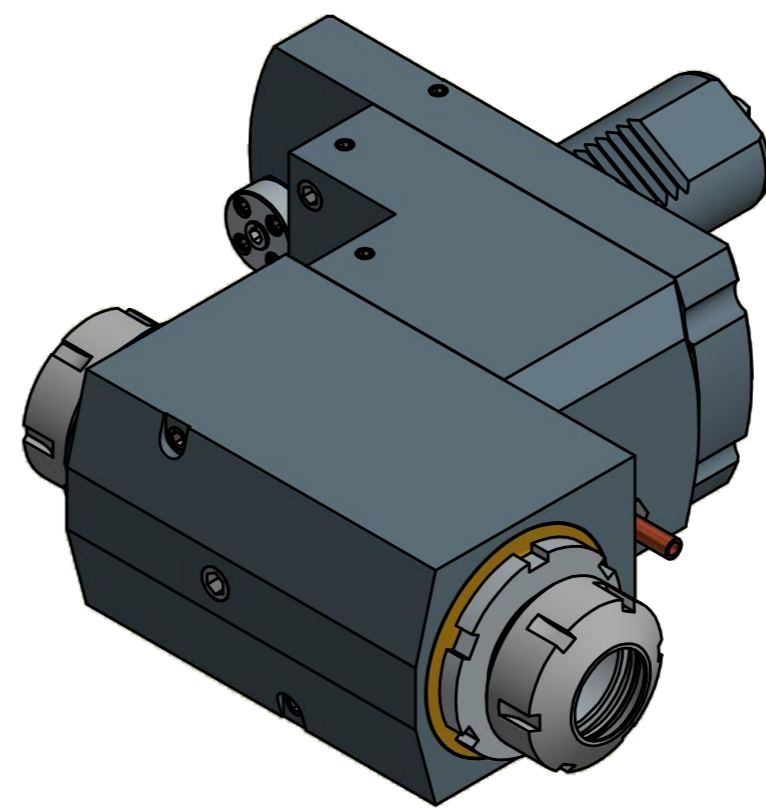

Spannzange / collet ER32 DIN6499  
 Spannbereich / clamping range: 2,0 - 20,0

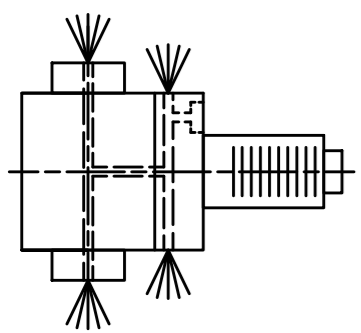

Innen- und Aussenkuehlung / Inside and outside coolant supply  
 Kein Trockenlauf / No dry run  
 Kuehlmittefiltrierung-50µ / coolant filtration-50µ

Copyright **EWS Tool Technologies**  
 Weitergabe und Vervielfaeltigung dieser Unterlage,  
 Verwertung und Mitteilung ihres Inhalts nicht  
 gestattet, soweit nicht ausdrecklich zugestanden.  
 Zuwiderhandlungen verpflichten zu Schadenersatz.

<p>Bemerkung - Note                  Nicht ohne Kuehlmittel betreiben!                  Not for use without coolant-fluid!</p>	<p>Technische Daten - technical data                  Weight = 11,441 [kg]                  Torque max. (M1/M2) = 50 / 50   50 [Nm]                  Speed max. (n1/n2) = 6000 / 6000   6000 [1/min]                  Gear ratio (i)=n1:n2 = 1:1   1:1                  Pressure (pmax) = 25 [bar]</p>	<p>Benennung - Title                  Radial Bohr und Fräskopf, zurückges                  Radial drill. and mill. head offset</p>	<p><b>EWS</b> Tool Technologies                  EWS Weigle GmbH &amp; Co. KG                  Maybachstr. 1                  D-73066 Uhlingen                  www.ews-tool.de</p>	<p>Technische Aenderungen vorbehalten!                  Subject to technical modifications!                  IDENT: DEWS104068                  REV: -/B</p>	<p>Nr. - No.                  80.4032DSQT15LIK                  MNR.                  131672</p>
--	--	--	---	--	--

