

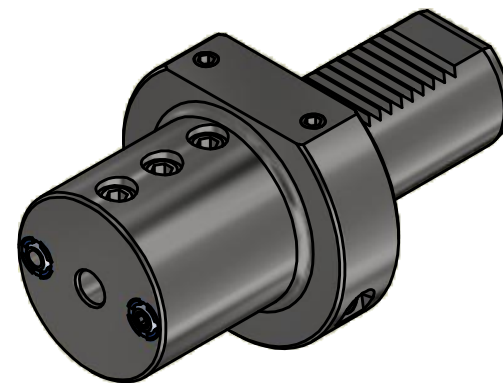



Achtung: Darf nur mit Verschlussstopfen verwendet werden!
 Attention: May only be used with sealing plug!

Anzugsmoment: 40 Nm
 Tightening torque: 40 Nm



Copyright **EWS Tool Technologies**
 Weitergabe und Vervielfaeltigung dieser Unterlage,
 Verwertung und Mitteilung ihres Inhalts nicht
 gestattet, soweit nicht ausdrecklich zugestanden.
 Zuwiderhandlungen verpflichten zu Schadenersatz.

Bemerkung - Note	Technische Daten - technical data Weight = 2.176 [kg]	Benennung - Title Bohrstangenhalter Boring bar holder	 EWS Weigle GmbH & Co. KG Maybachstr. 1 D-73066 UHINGEN www.ews-tools.de	Technische Aenderungen vorbehalten! Subject to technical modifications! IDENT: DEWS120468	 REV: -/A MNR. 135661	
			Nr. - No. 19.4010			