

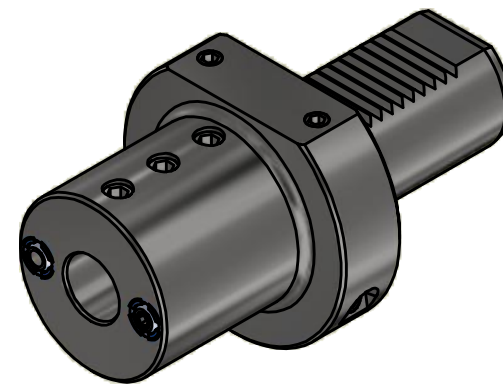



Achtung: Darf nur mit Verschlussstopfen verwendet werden!  
 Attention: May only be used with sealing plug!

Anzugsmoment: 40 Nm  
 Tightening torque: 40 Nm



Copyright **EWS Tool Technologies**  
 Weitergabe und Vervielfaeltigung dieser Unterlage,  
 Verwertung und Mitteilung ihres Inhalts nicht  
 gestattet, soweit nicht ausdruendlich zugestanden.  
 Zuwiderhandlungen verpflichten zu Schadenersatz.

Bemerkung - Note	Technische Daten - technical data Weight = 2.081 [kg]	Benennung - Title <b>Bohrstangenhalter</b> <i>Boring bar holder</i>	 EWS Weigle GmbH & Co. KG Maybachstr. 1 D-73066 UHINGEN www.ews-tools.de	Technische Aenderungen vorbehalten! Subject to technical modifications! IDENT: DEWS115797	 REV: -/C MNR. 135665	
		Nr. - No. 19.4020				