

Spannzange / collet ER25 DIN6499  
 Spannbereich / clamping range: 1,0 - 16,0

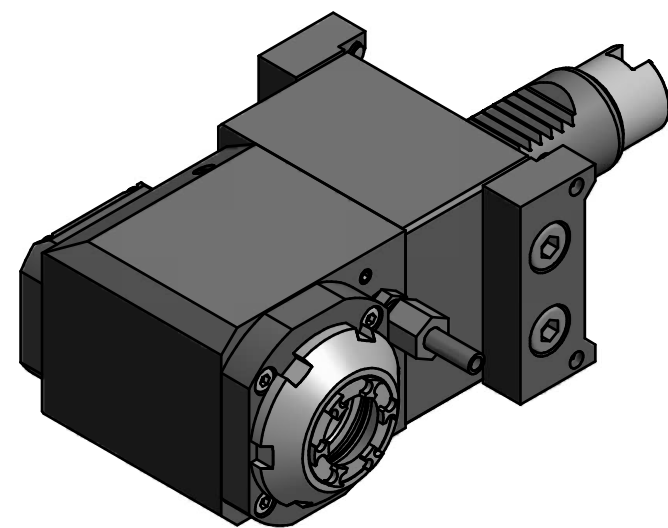

 Hakenschlüssel mit Nase  
 Hook wrench with nose end  
 DIN1810 A 52x55

 Spannzangenschlüssel für innenliegende Mutter  
 Clamping wrench for internal collet  
 EA 25 K

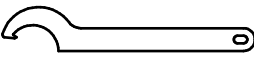
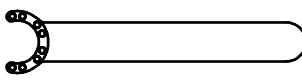
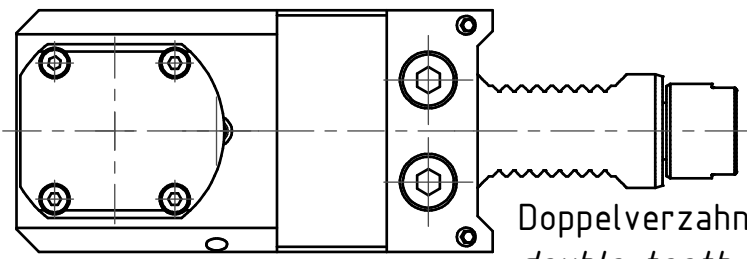

Doppelverzahnung Lizenz Traub  
 double tooth system licence Traub

Copyright **EWS Tool Technologies**  
 Weitergabe und Vervielfältigung dieser Unterlage, Verwertung und Mitteilung ihres Inhalts nicht gestattet, soweit nicht ausdrücklich zugestanden. Zuwiderhandlungen verpflichten zu Schadenersatz.

Bemerkung - Note	Technische Daten - technical data M1 / M2 = 25 / 25 Nm n1 / n2 = 8000 / 8000 1/min i (N1:N2) = 1:1	Benennung - Title <b>Radial Bohr und Fräskopf</b> <i>Radial drilling and milling head</i>	name	date	Technische Änderungen vorbehalten! Subject to technical modifications!	 DIN A3
			drawing	Theiss		
			 EWS Weigete GmbH & Co. KG Maybachstr. 1 D-73066 Uhingen Tel. +49(0)7161/93040-100		Nr. <b>60.3025TNX65RLIM</b>	
			MNR: 14.0039		IDENT: D-EWS-050900 A	
			Blatt - page		1 (1)	