

Spannzange / collet ER32 DIN6499
 Spannungsbereich / clamping range: 2,0 - 20,0

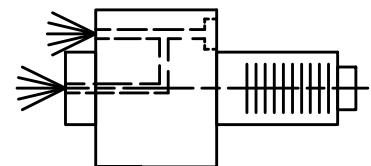

Innen- und Aussenkuehlung / Inside and outside coolant supply
 Kuehlmittelfiltrierung 50μ / coolant filtration 50μ

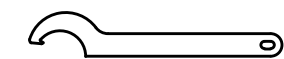
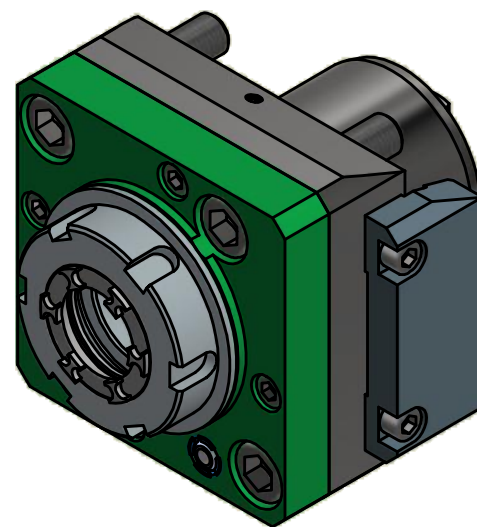

Hakenschlüssel
 mit Nase
 Hook wrench with
 nose end
 DIN1810 A 58x62

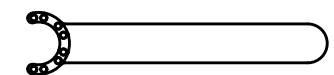

Spannzangenschlüssel für
 innenliegende Mutter
 Clamping wrench for
 internal collet
 EA 32 K

Copyright **EWS Tool Technologies**
 Weitergabe und Vervielfaeltigung dieser Unterlage,
 Verwertung und Mitteilung ihres Inhalts nicht
 gestattet, soweit nicht ausdruercklich zugestanden.
 Zuwiderhandlungen verpflichten zu Schadenersatz.

Bemerkung - Note
 Für Trockenlauf geeignet!
 Use without coolant fluid allowed!

Technische Daten - technical data
 Weight = 4.667 [kg]
 Torque max. (M1/M2) = 50 / 50 [Nm]
 Speed max. (n1/n2) = 6000 / 6000 [1/min]
 Gear ratio (i)=n1:n2 = 1:1
 Pressure (pmax) = 70 [bar]

Benennung - Title
 Axial Bohr und Fräskopf
 Axial drilling and milling head



Nr. - No.
 40.6032LB2000BMTIKDIM

Technische Aenderungen vorbehalten!
 Subject to technical modifications!
 IDENT: DEWS024996

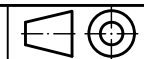

REV: -/D

MNR.
 14 14 15

