

Spannzange / collet ER25 DIN6499
 Spannungsbereich / clamping range: 1,0 - 16,0

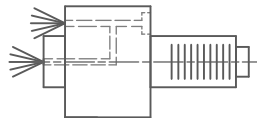

Innen- und Aussenkuehlung / Inside and outside coolant supply
 Kein Trockenlauf / No dry run
 Kuehlmittelfiltrierung 50μ / coolant filtration 50μ

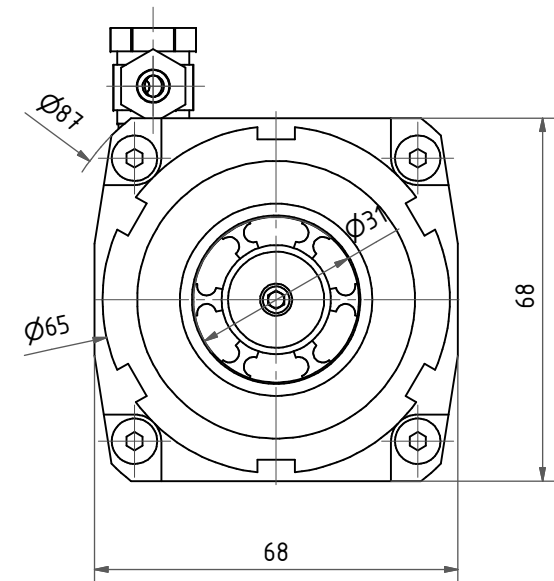
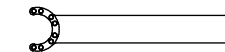
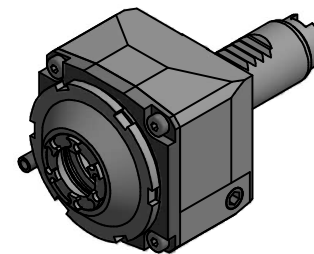

Spannzangenschlüssel für
 innenliegende Mutter
 Clamping wrench for
 internal collet
 EA 25 K

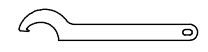

Hakenschlüssel
 mit Nase
 Hook wrench with
 nose end
 DIN1810 A 58x62

Copyright **EWS Tool Technologies**
 Weitergabe und Vervielfaeltigung dieser Unterlage,
 Verwertung und Mitteilung ihres Inhalts nicht
 gestattet, soweit nicht ausdruercklich zugestanden.
 Zuwiderhandlungen verpflichten zu Schadenersatz.

| | | | | | | |
|---|---|--|--|--|--|-----------|
| <p>Bemerkung - Note</p> <p>Nicht ohne Kuehlmittel betreiben! <i>Not for use without coolant-fluid!</i></p> | <p>Technische Daten - technical data</p> <p>Weight = 1.774 [kg] Torque max. (M1/M2) = 25 / 25 [Nm] Speed max. (n1/n2) = 8000 / 8000 [1/min] Gear ratio (i) = n1:n2 1:1 Pressure (pmax) = 25 [bar]</p> | <p>Benennung - Title</p> <p>Axial Bohr und Fräskopf Axial drilling and milling head</p> | <p>EWS Tool Technologies <small>EWS Weigelt GmbH & Co. KG Maybachstr. 1 D-73066 Uhlingen www.ews-tools.de</small></p> <p>Nr. - No. 40.2525G200IKIM</p> | <p>Technische Aenderungen vorbehalten! Subject to technical modifications!</p> <p>IDENT: D-EWS-116198</p> | <p>REV: -/A</p> <p>MNR. 148075</p> | <p>QR</p> |
|---|---|--|--|--|--|-----------|