

Spannzange / Collet ER16 DIN6499  
 Spannbereich / Clamping range: 1,0 - 10,0

Gewindebohrzange / Tapping Collet  
 ET-1-16 M1-M6

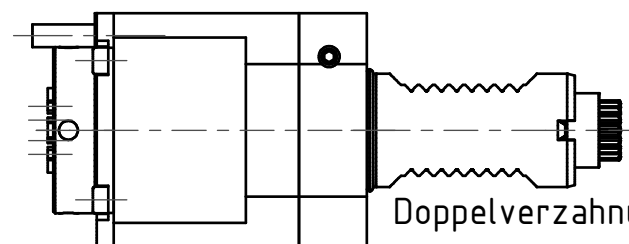

Doppelverzahnung Lizenz Traub  
*double tooth system licence Traub*

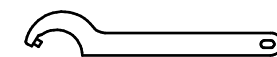
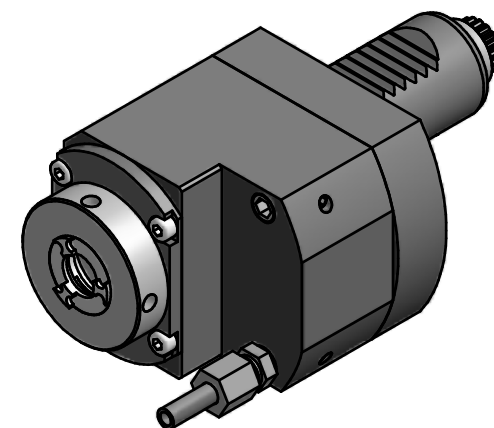

Hakenschlüssel  
 mit Zapfen  
*Hook wrench  
 with fixed pin*  
 DIN1810 B 45x50

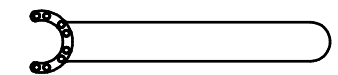

Spannzangenschlüssel für  
 innenliegende Mutter  
*Clamping wrench for  
 internal collet*  
 EA 16 K

Copyright **EWS Tool Technologies**  
 Weitergabe und Vervielfältigung dieser Unterlage,  
 Verwertung und Mitteilung ihres Inhalts nicht  
 gestattet, soweit nicht ausdrücklich zugestanden.  
 Zuwiderhandlungen verpflichten zu Schadenersatz.

Bemerkung - Note
------------------

Technische Daten - technical data	
Weight	= 2.295 [kg]
Torque max. (M1/M2)	= 15 / 5 [Nm]
Speed max. (n1/n2)	= 6000 / 18000 [1/min]
Gear ratio (i)=n1:n2	= 1:3,053

Benennung - Title	
<b>Axial Bohr und Fräskopf</b>	
<i>Axial drilling and milling head</i>	

<b>EWS</b> Tool Technologies	EWS Weigele GmbH & Co. KG Maybachstr. 1 D-73066 Uhingen www.ews-tools.de
	Nr. - No. <b>40.3016CTXRLI13GLIM</b>

Technische Änderungen vorbehalten! Subject to technical modifications!	IDENT: D-EWS-084846
REV: A/-	MNR. <b>149153</b>

