

W-Verzahnung Lizenz Index-Werke  
*W-tooth system licence Index-Corporation*

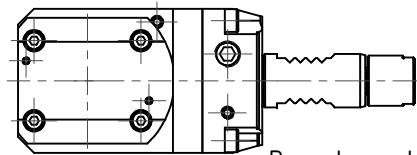

Spannzange / *collet* ER20 DIN6499  
 Spannbereich / *clamping range*: 1,0 - 13,0

Gewindebohrzange / *tapping collet*  
 ET-1-20 M2-M6



Doppelverzahnung Lizenz Traub  
*double tooth system licence Traub*

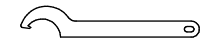
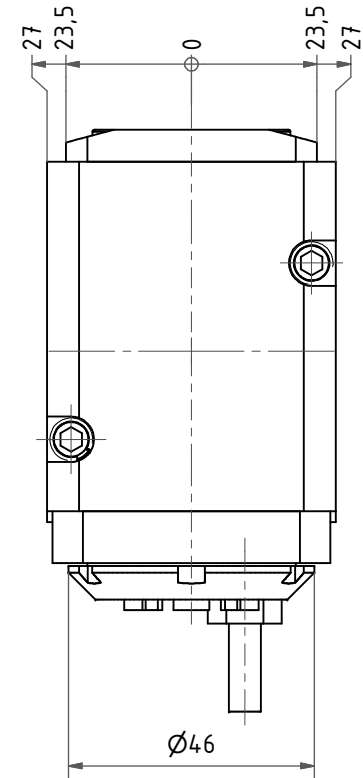
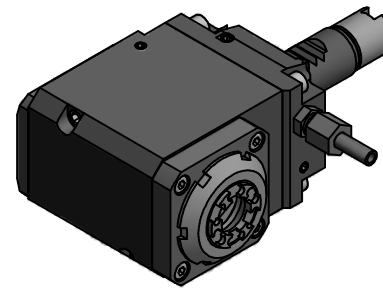

Hakenschlüssel  
 mit Nase  
*Hook wrench with  
 nose end*  
 DIN1810 A 45x50

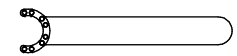

Spannzangenschlüssel für  
 innenliegende Mutter  
*Clamping wrench for  
 internal collet*  
 EA 20 K

Copyright **EWS Tool Technologies**  
 Weitergabe und Vervielfältigung dieser Unterlage,  
 Verwertung und Mitteilung ihres Inhalts nicht  
 gestattet, soweit nicht ausdrücklich zugestanden.  
 Zuwiderhandlungen verpflichten zu Schadenersatz.

Bemerkung - *Note*

Technische Daten - *technical data*

*Weight* = 2.314 [kg]  
*Torque max.* (M1/M2) = 11 / 11 [Nm]  
*Speed max.* (n1/n2) = 8000 / 8000 [1/min]  
*Gear ratio* (i1)=n1:n2 = 1:1

Benennung - *Title*

**Radial Bohr und Fräskopf**  
*Radial drilling and milling head*



Nr. - *No.*

60.2020C100RLWIM

EWS Weigelt GmbH & Co. KG  
 Maybachstr. 1  
 D-73066 Uhingen  
 www.ews-tools.de

Technische Änderungen vorbehalten!  
*Subject to technical modifications!*

IDENT: DEWS007488

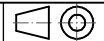

REV: -/B

MNR.

150368

