

Schwenkbereich $\pm 92^\circ$
Swivel area $\pm 92^\circ$

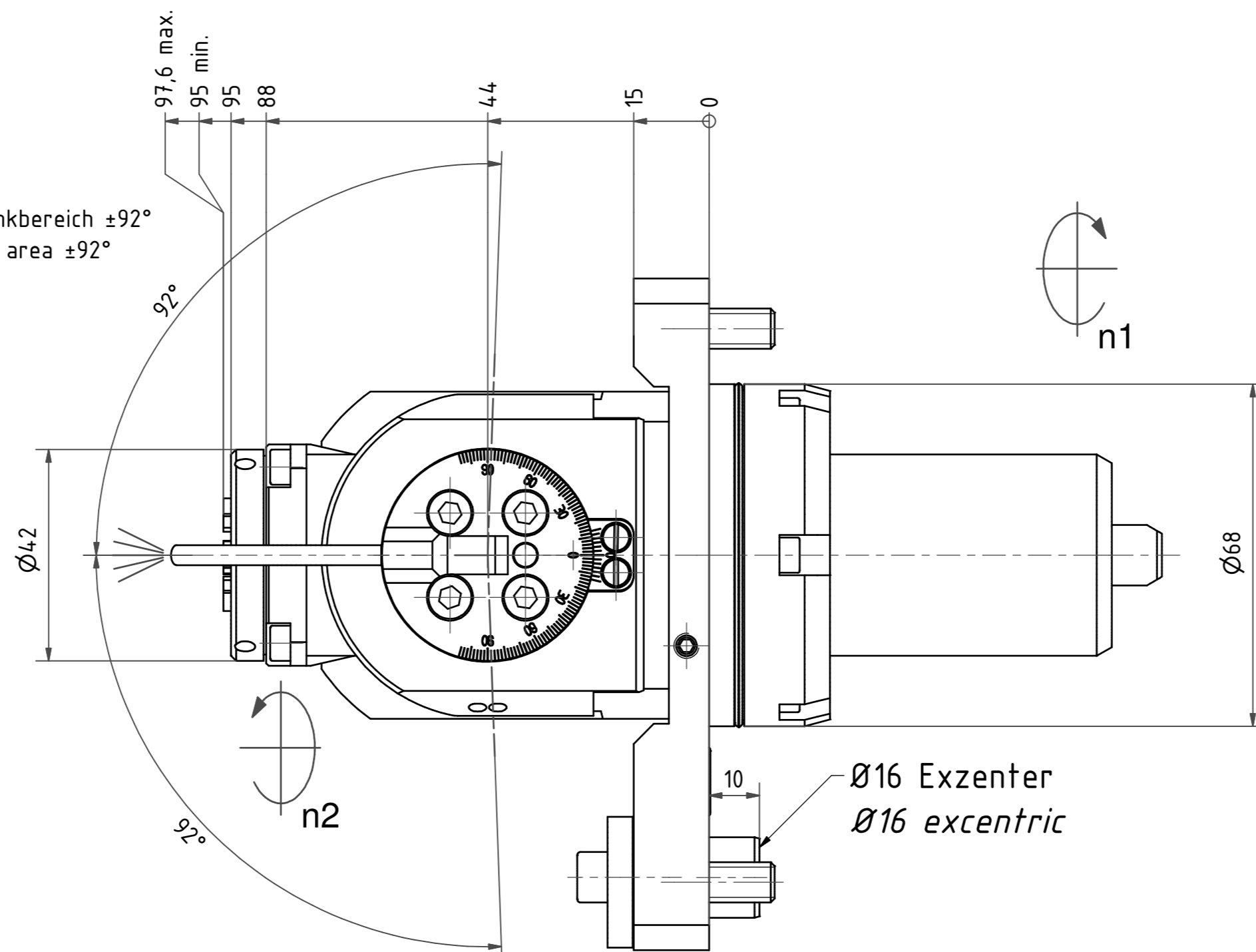

Spannzange / Collet ER16 DIN6499
Spannbereich / Clamping range: 1,0 - 10,0

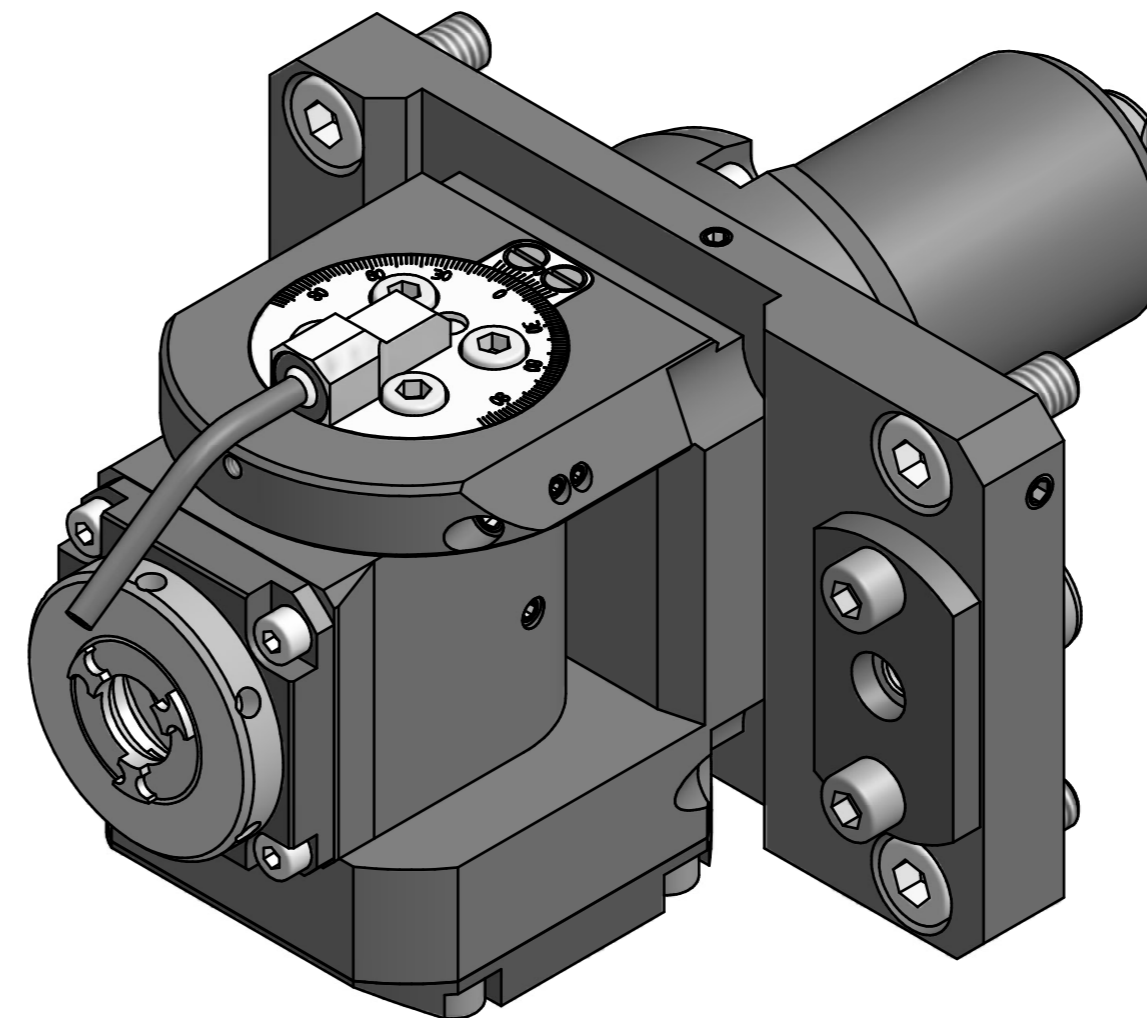
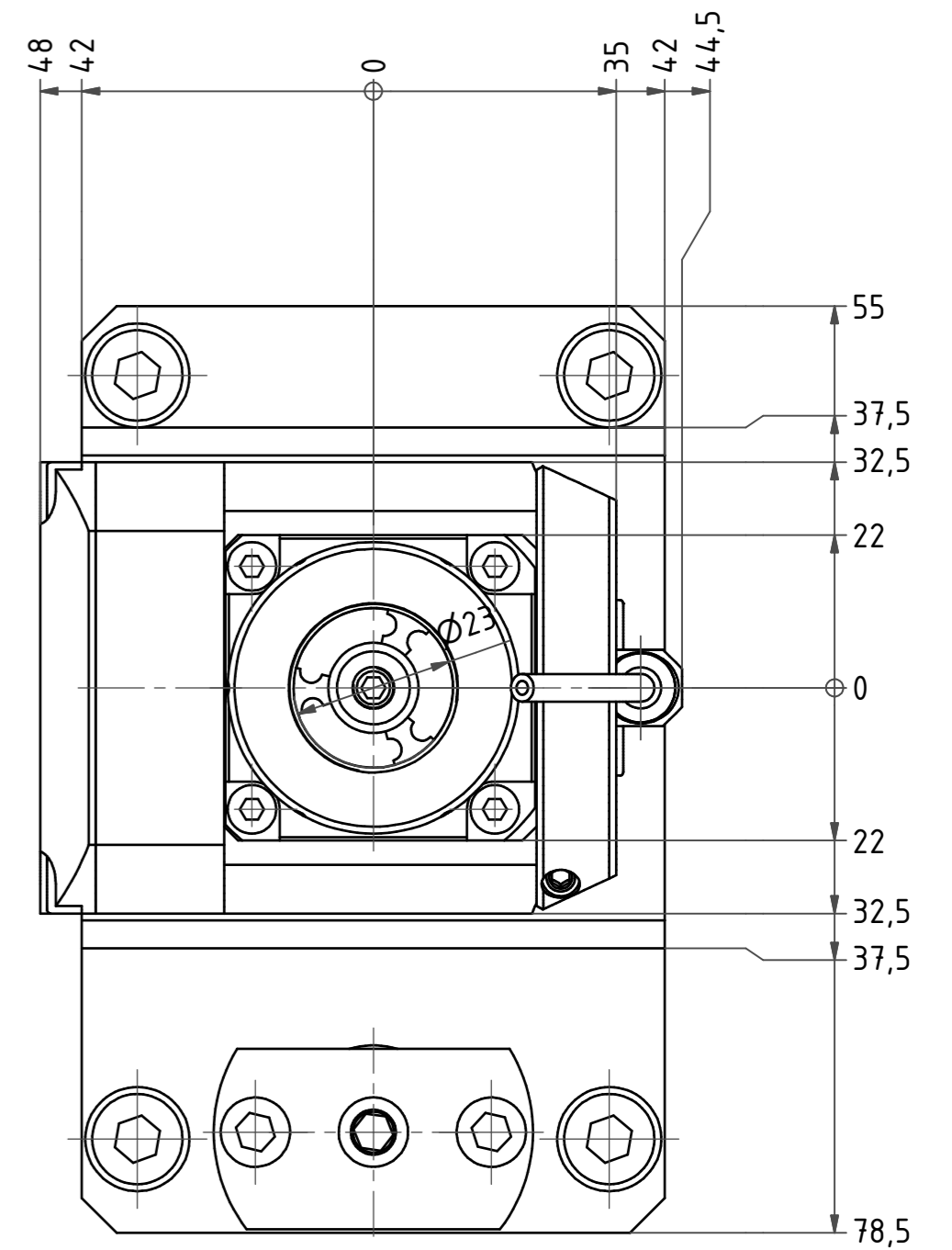

Hakenschlüssel
mit Zapfen
Hook wrench
with fixed pin
DIN1810 B 40x42

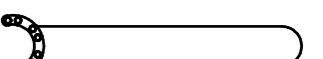
Spannzangenschlüssel für
innenliegende Mutter
Clamping wrench for
internal collet
EA 16 K

Copyright **EWS Tool Technologies**
Weitergabe und Vervielfältigung dieser Unterlage,
Verwertung und Mitteilung ihres Inhalts nicht
gestattet, soweit nicht ausdrücklich zugestanden.
Zuwendungen verpflichten zu Schadenersatz.

Bemerkung - Note	Technische Daten - Technical data		Benennung - Title	name	date	Technische Änderungen vorbehalten! Subject to technical modifications!	
	M ₁ / M ₂ = 16 / 16 Nm	n ₁ / n ₂ = 6000 / 6000 1/min					Schmid
	i (N ₁ :N ₂) = 1:1						
			Schwenkkopf Swivel head	EWS EWS Weigte GmbH & Co. KG Maybachstr. 1 D-72096 Ulm/lingen Tel. +49(0)7161/93040-100			DIN A2
						MNR: 155376	IDENT: D-EWS-163015 - Blatt - page 1 (1)