

Spannzange / collet ER32 DIN6499
 Spannbereich / clamping range: 2,0 - 20,0

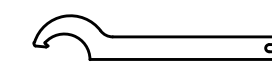

Hakenschlüssel
 mit Nase
 Hook wrench with
 nose end
 DIN1810 A 68x75

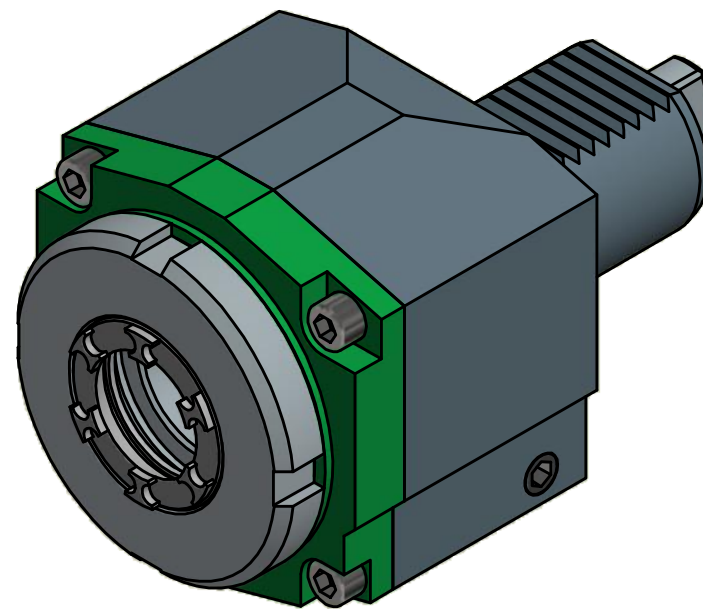
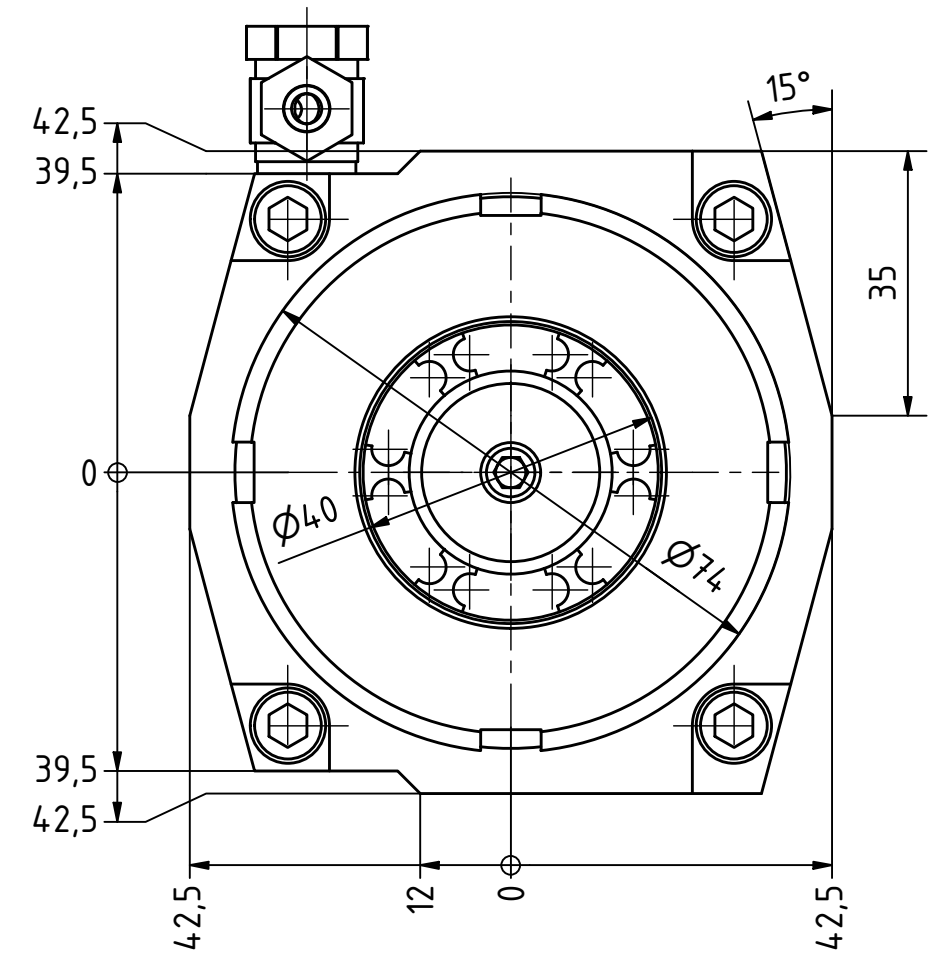
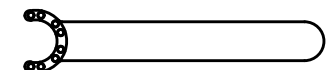

Spannzangenschlüssel für
 innenliegende Mutter
 Clamping wrench for
 internal collet
 EA 32 K

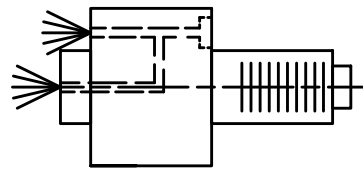

Innen- und Aussenkuehlung / Inside and outside coolant supply
 Kein Trockenlauf / No dry run
 Kuehlmittelfiltrierung $\le 50\mu$ / coolant filtration $\le 50\mu$

Copyright **EWS Tool Technologies**
 Weitergabe und Vervielfaeltigung dieser Unterlage,
 Verwertung und Mitteilung ihres Inhalts nicht
 gestattet, soweit nicht ausdrecklich zugestanden.
 Zuwiderhandlungen verpflichten zu Schadenersatz.

Bemerkung - Note
 Nicht ohne Kuehlmittel betreiben!
 Not for use without coolant-fluid!

Technische Daten - technical data	
Weight	= 3.471 [kg]
Torque max. (M1/M2)	= 50 / 50 [Nm]
Speed max. (n1/n2)	= 6000 / 6000 [1/min]
Gear ratio (i)=n1:n2	= 1:1
Pressure (pmax)	= 25 [bar]

Benennung - Title
 Axial Bohr und Fräskopf
 Axial drilling and milling head



Nr. - No.
 40.4032NZ2000IKIM

Technische Aenderungen vorbehalten!
 Subject to technical modifications!
 IDENT: DEWS093270

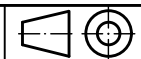

REV: -/B

MNR.

157496

