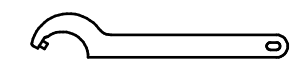
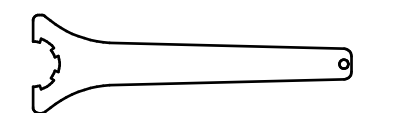

Innen- und Aussenkuehlung / Inside and outside coolant supply
 Kein Trockenlauf / No dry run
 Kuehlmittelfiltrierung <math>< 50\mu</math> / coolant filtration <math>< 50\mu</math>

 Hakenschlüssel mit Zapfen
 Hook wrench with fixed pin
 DIN1810 B 40x42

 Spannzangenschlüssel
 Clamping wrench
 225

Copyright **EWS Tool Technologies**
 Weitergabe und Vervielfaeltigung dieser Unterlage, Verwertung und Mitteilung ihres Inhalts nicht gestattet, soweit nicht ausdruuecklich zugestanden. Zuwiderhandlungen verpflichten zu Schadenersatz.

<p>Bemerkung - Note Nicht ohne Kuehlmittel betreiben! Not for use without coolant-fluid!</p>	<p>Technische Daten - technical data M1 / M2 = 25 / 25 Nm n1 / n2 = 12000 / 12000 1/min i (N1:N2) = 1:1 pmax = 70 bar</p>	<p>Benennung - Title Radial Bohr und Fräskopf Radial drilling and milling head</p>	<table border="1"> <tr> <th>name</th> <th>date</th> </tr> <tr> <td>Schmid</td> <td>22.05.2012</td> </tr> </table>	name	date	Schmid	22.05.2012	<p>Technische Aenderungen vorbehalten! Subject to technical modifications!</p> <p>Nr. 60.3025LCTXLIKTFHSD12</p> <p>MNR: 159735 IDENT: D-EWS-121015 - Blatt - page 1 (1)</p>	 <p>DIN A3</p>
name	date								
Schmid	22.05.2012								