

EWS-Varia VX3

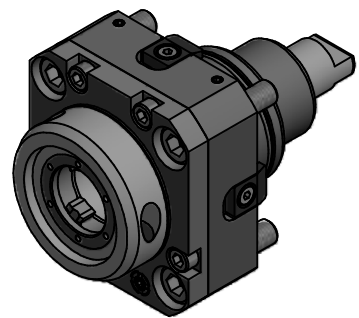
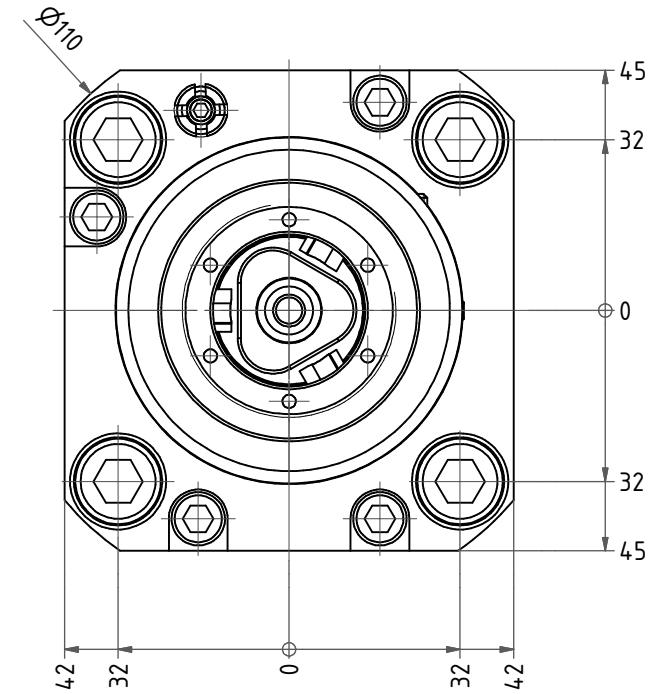
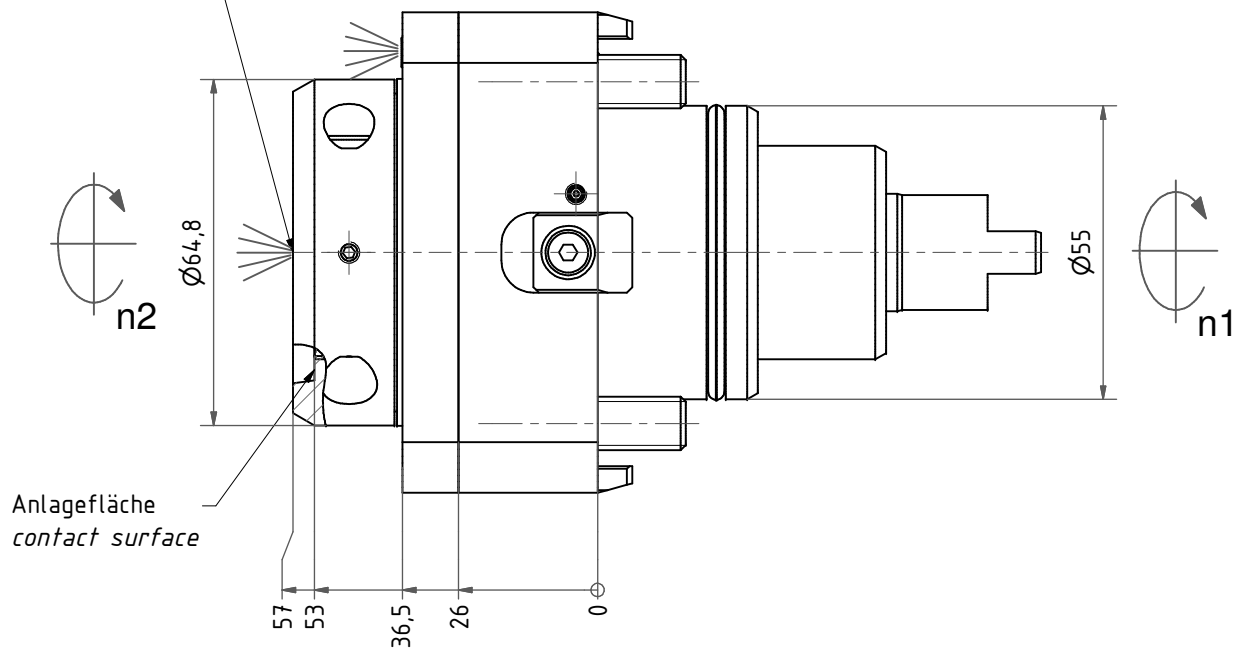

Innen- und Aussenkuehlung / Inside and outside coolant supply
Kuehlmittelfiltrierung-50µ / coolant filtration-50µ

Copyright **EWS Tool Technologies**
Weitergabe und Vervielfaeltigung dieser Unterlage,
Verwertung und Mitteilung ihres Inhalts nicht
gestattet, soweit nicht ausdrecklich zugestanden.
Zuwiderhandlungen verpflichten zu Schadenersatz.

<p>Bemerkung - Note</p> <p>Für Trockenlauf geeignet! Use without coolant fluid allowed!</p>	<p>Technische Daten - technical data</p> <p>Weight = 2.915 [kg] Torque max. (M1/M2) = 50 / 50 [Nm] Speed max. (n1/n2) = 6000 / 6000 [1/min] Gear ratio (i)=n1:n2 = 1:1 Pressure (pmax) = 70 [bar]</p>	<p>Benennung - Title</p> <p>Axial Bohr und Fräskopf Axial drilling and milling head</p>	<p>EWS Tool Technologies EWS Weigelt GmbH & Co. KG Maybachstr. 1 D-73066 Uhlingen www.ews-tools.de</p> <p>Nr. - No. 40.55VX3VL2IKD</p>	<p>Technische Aenderungen vorbehalten! Subject to technical modifications!</p> <p>IDENT: DEWS022701 REV: -/B</p> <p>MNR. 165330</p>	
---	---	---	--	--	--