

Innen- und Aussenkuehlung / Inside and outside coolant supply
 Kuehlmittelfiltrierung-50µ / coolant filtration-50µ

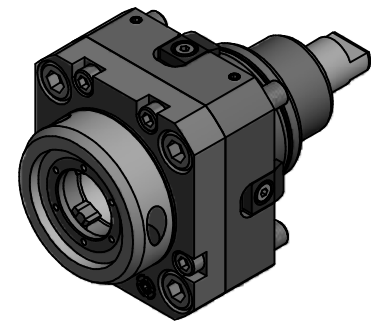

Copyright **EWS Tool Technologies**
 Weitergabe und Vervielfaeltigung dieser Unterlage,
 Verwertung und Mitteilung ihres Inhalts nicht
 gestattet, soweit nicht ausdrecklich zugestanden.
 Zuwiderhandlungen verpflichten zu Schadenersatz.

| | | | | | |
|--|---|--|--|--|-----------|
| <p>Bemerkung - Note</p> <p>Für Trockenlauf geeignet! <i>Use without coolant fluid allowed!</i> mit Kegelrollenlager <i>with taper roller bearing(s)</i></p> | <p>Technische Daten - technical data</p> <p>Weight = 3.201 [kg] Torque max. (M1/M2) = 50 / 50 [Nm] Speed max. (n1/n2) = 6000 / 6000 [1/min] Gear ratio (i)=n1:n2 = 1:1 Pressure (pmax) = 70 [bar]</p> | <p>Benennung - Title</p> <p>Axial Bohr und Fräskopf Axial drilling and milling head</p> | <p>EWS Tool Technologies <small>EWS Weigelt GmbH & Co. KG Maybachstr. 1 D-73066 Uhingen www.ews-tools.de</small></p> | <p>Technische Aenderungen vorbehalten! <i>Subject to technical modifications!</i></p> <p>IDENT: DEWS022697 REV: -/B MNR. 166423</p> | <p>QR</p> |
|--|---|--|--|--|-----------|