

Spannzange / collet ER25 DIN6499
 Spannbereich / clamping range: 1,0 - 16,0

Gewindebohrzange / tapping collet
 ET-1-25 M3-M12

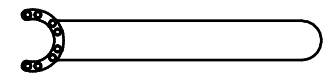

Spannzangenschlüssel für
 innenliegende Mutter
*Clamping wrench for
 internal collet*
 EA 25 K

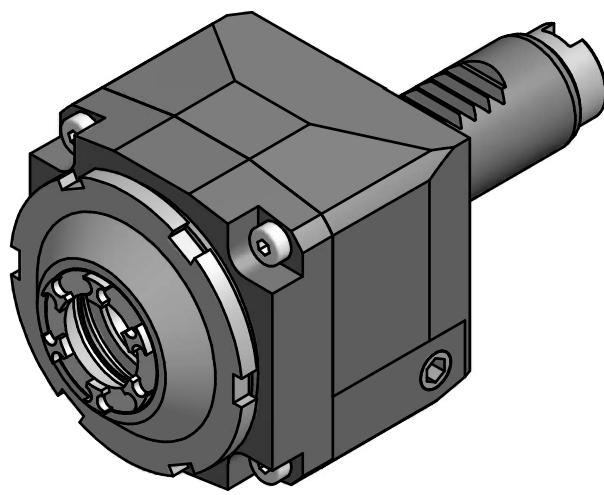
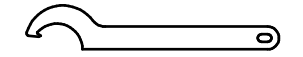

Hakenschlüssel
 mit Nase
*Hook wrench with
 nose end*
 DIN1810 A 58x62

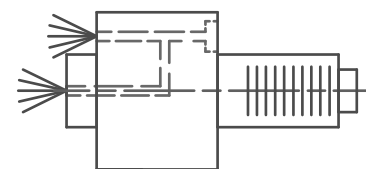

Innen- und Aussenkuehlung / Inside and outside coolant supply
 Kein Trockenlauf / No dry run
 Kuehlmittelfiltrierung 50μ / coolant filtration 50μ

Copyright **EWS Tool Technologies**
 Weitergabe und Vervielfaeltigung dieser Unterlage,
 Verwertung und Mitteilung ihres Inhalts nicht
 gestattet, soweit nicht ausdruuecklich zugestanden.
 Zuwiderhandlungen verpflichten zu Schadenersatz.

Bemerkung - Note Nicht ohne Kuehlmittel betreiben! <i>Not for use without coolant-fluid!</i> mit Kegelrollenlager <i>with taper roller bearing(s)</i>	Technische Daten - technical data $M1 / M2 = 25 / 25 \text{ Nm}$ $n1 / n2 = 5000 / 5000 \text{ 1/min}$ $i (N1:N2) = 1:1$ $p_{max} = 25 \text{ bar}$	Benennung - Title Axial Bohr und Fräskopf <i>Axial drilling and milling head</i>	name M. Simonello	date 02.03.2015	Technische Aenderungen vorbehalten! <i>Subject to technical modifications!</i> Nr. 40.2525KRG200IKIM	
			EWS Weigele GmbH & Co. KG Maybachstr. 1 D-73066 Uhingen Tel. +49(0)7161/93040-100			