

Bewegungsablauf bei 1 Umdrehung der Antriebsspindel:
motion-sequence of 1 revolution of the driveshaft:

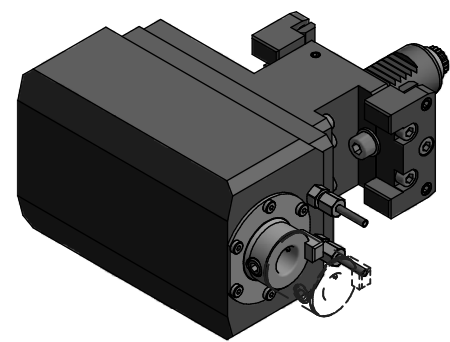
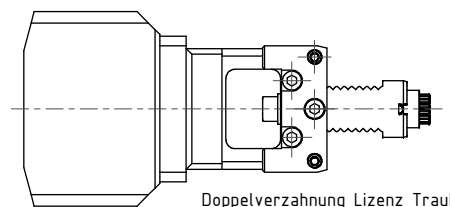
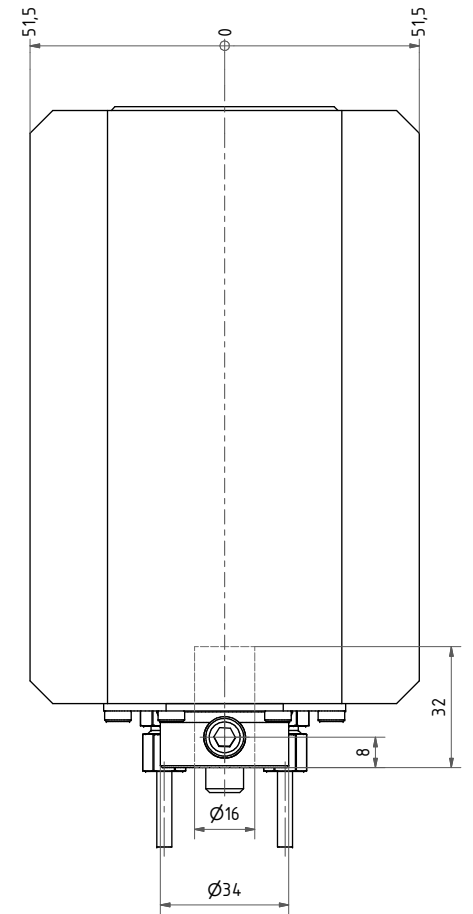
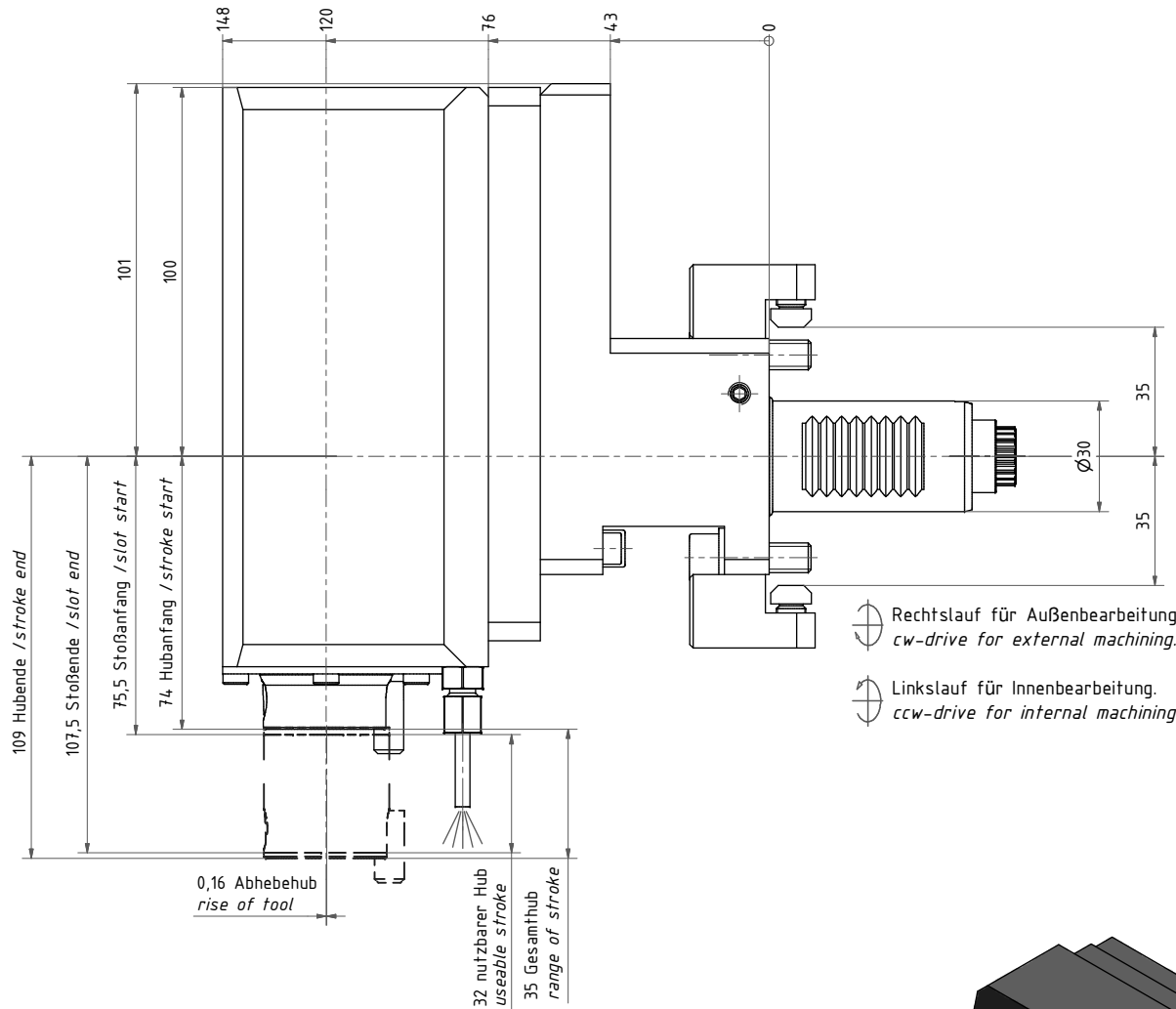
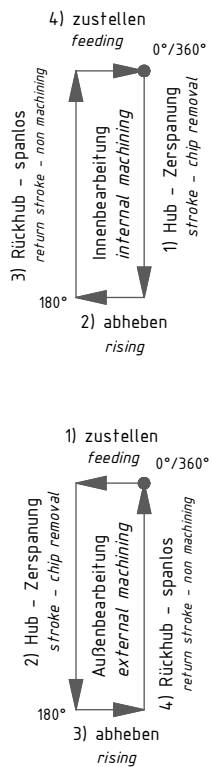

Bemerkung - Note Fett-Dauerschmierung grease life-time lubrication	Technische Daten - Technical data
	Weight = 10.795 [kg] Torque max. (M1/M2) = 20 / [Nm] Speed max. (n1/n2) = 1000 / [1/min] Gear ratio (i)=n1:n2 = 1 Hub/U

Benennung - Title Linear Nutstoßapparat Push type slotter
--

 EWS Werkzeug GmbH & Co. KG Industrieweg 1 D-72084 Löhningen www.ews-tool.de	Technische Änderungen vorbehalten! Subject to technical modifications! IDENT: D-EWS-175628	 REV: -/A 1998	
	Nr. - No. 89.3016WNE365RLX120	180830	

Copyright **EWS Tool Technologies**
 Weitergabe und Vervielfältigung dieser Unterlage,
 Verwertung und Mitteilung ihres Inhalts nicht
 gestattet, soweit nicht ausdrücklich zugestanden.
 Zuwiderhandlungen verpflichten zu Schadenersatz.