

Spannzange / collet ER25 DIN6499
 Spannbereich / clamping range: 1,0 - 16,0

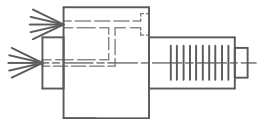

Innen- und Aussenkuehlung / Inside and outside coolant supply
 Kuehlmittelfiltrierung=50µ / coolant filtration=50µ

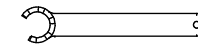
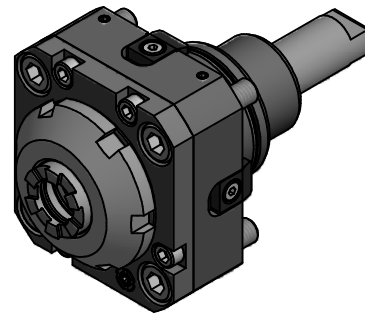

Spannzangenschlüssel für
 innenliegende Mutter
 Clamping wrench for
 internal collet
 225AX

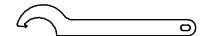

Hakenschlüssel
 mit Nase
 Hook wrench with
 nose end
 DIN1810 A 68x75

Copyright **EWS Tool Technologies**
 Weitergabe und Vervielfaeltigung dieser Unterlage,
 Verwertung und Mitteilung ihres Inhalts nicht
 gestattet, soweit nicht ausdruercklich zugestanden.
 Zuwiderhandlungen verpflichten zu Schadenersatz.

<p>Bemerkung - Note</p> <p>Für Trockenlauf geeignet! <i>Use without coolant fluid allowed!</i></p>	<p>Technische Daten - technical data</p> <p>Weight = 2.827 [kg] Torque max. (M1/M2) = 50 / 50 [Nm] Speed max. (n1/n2) = 6000 / 6000 [1/min] Gear ratio (i)=n1:n2 = 1:1 Pressure (pmax) = 70 [bar]</p>	<p>Benennung - Title</p> <p>Axial Bohr und Fräskopf Axial drilling and milling head</p>	<p>EWS Tool Technologies <small>EWS Weigelt GmbH & Co. KG Maybachstr. 1 D-73066 Ulm/ingen www.ews-tools.de</small></p>	<p>Technische Aenderungen vorbehalten! Subject to technical modifications!</p> <p>IDENT: DEWS007161</p>	<p>REV: -/A</p> <p>MNR.</p> <p>190678</p>	<p>QR</p>
---	---	--	--	--	--	------------------