

Innen- und Aussenkuehlung / Inside and outside coolant supply
 Kuehlmittelfiltrierung+50µ / coolant filtration+50µ

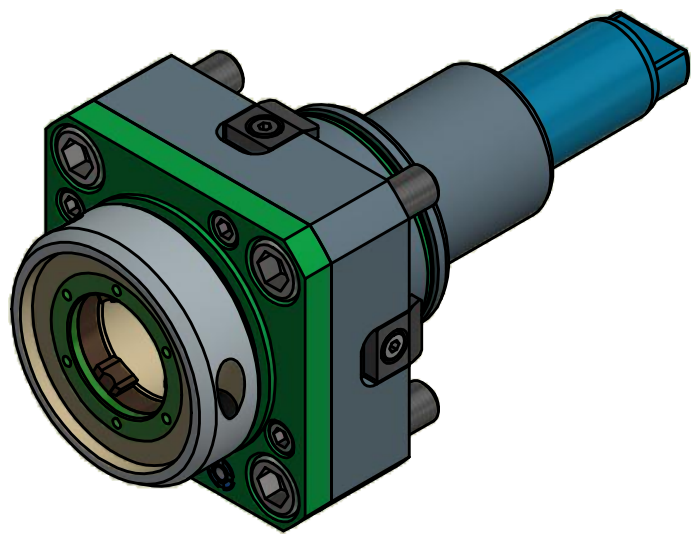

Copyright **EWS Tool Technologies**
 Weitergabe und Vervielfaeltigung dieser Unterlage,
 Verwertung und Mitteilung ihres Inhalts nicht
 gestattet, soweit nicht ausdrecklich zugestanden.
 Zuwiderhandlungen verpflichten zu Schadenersatz.

<p>Bemerkung - Note</p> <p>Für Trockenlauf geeignet! Use without coolant fluid allowed!</p>	<p>Technische Daten - technical data</p> <p>Weight = 4.050 [kg] Torque max. (M1/M2) = 70 / 70 [Nm] Speed max. (n1/n2) = 6000 / 6000 [1/min] Gear ratio (i)=n1:n2 = 1:1 Pressure (pmax) = 70 [bar]</p>	<p>Benennung - Title</p> <p>Axial Bohr und Fräskopf Axial drilling and milling head</p>	<p>EWS Tool Technologies</p> <p><small>EWS Weigle GmbH & Co. KG Maybachstr. 1 D-73066 UHINGEN www.ews-tools.de</small></p> <p>Nr. - No. 40.65VX4VT4IKD</p>	<p>Technische Aenderungen vorbehalten! Subject to technical modifications!</p> <p>IDENT: DEWS006027</p> <p>MNR. 195881</p>	<p>QR</p>
--	---	--	---	---	-----------