

Platzverhältnisse / space conditions

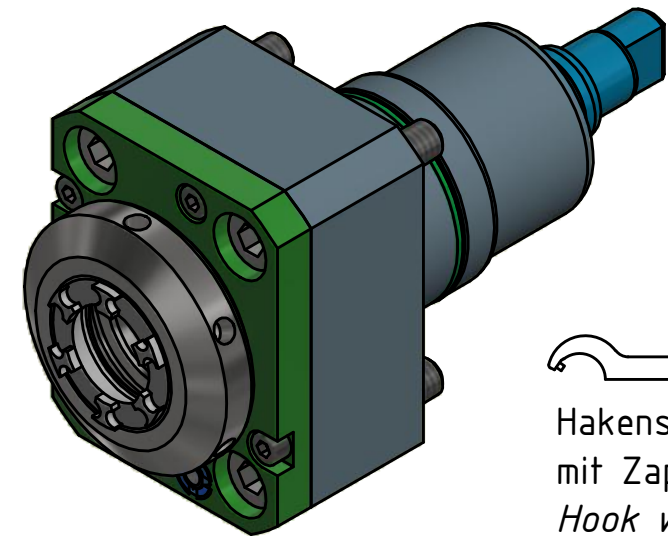
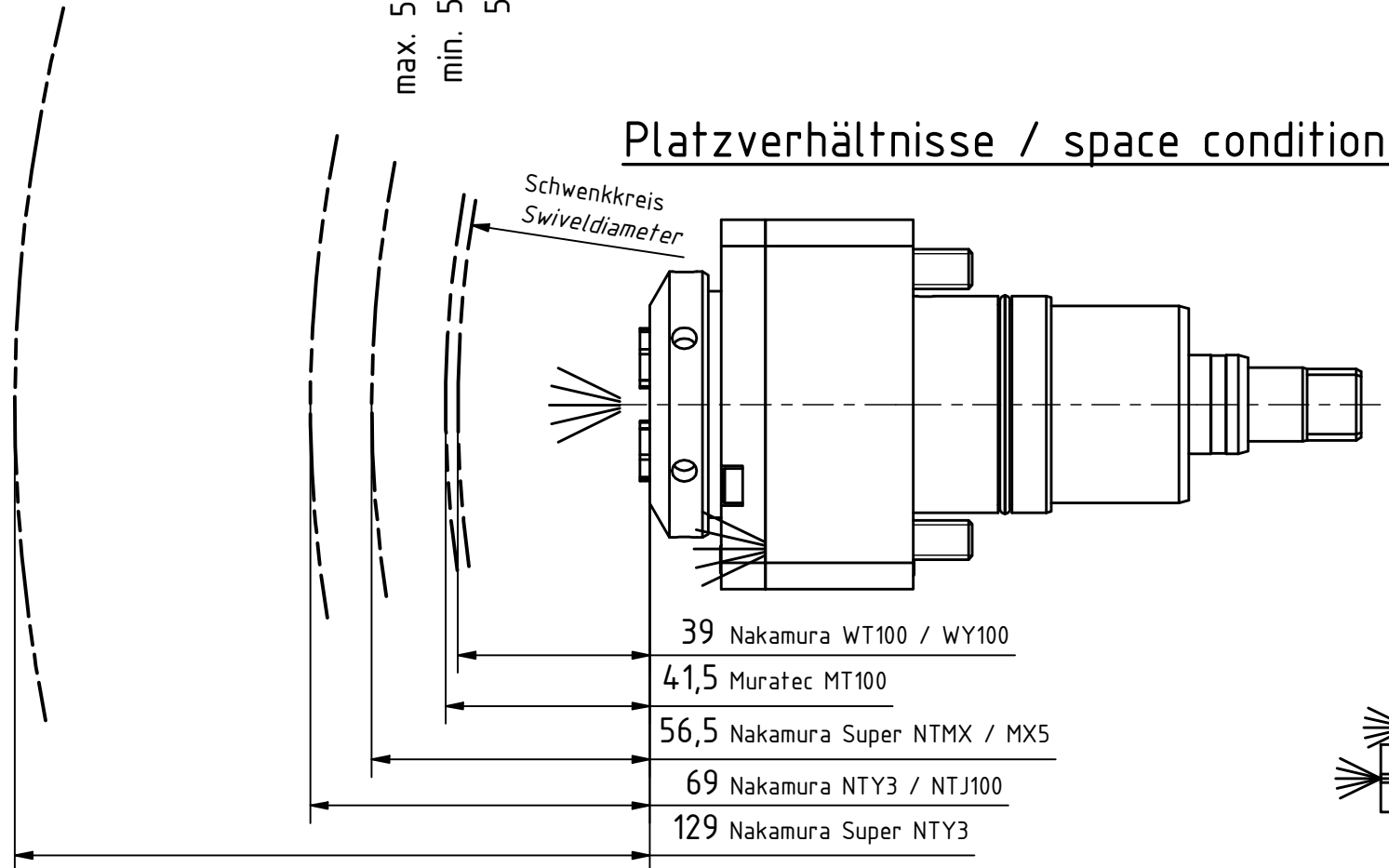
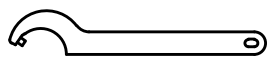
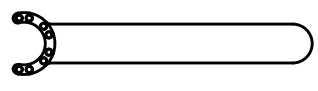

-  Hakenschlüssel mit Zapfen
Hook wrench with fixed pin
DIN1810 B 52x55
-  Spannzangenschlüssel für innenliegende Mutter
Clamping wrench for internal collet
EA 25 K

Innen- und Aussenkuehlung / Inside and outside coolant supply
Kuehlmittelfiltrierung 50μ / coolant filtration 50μ

Copyright **EWS Tool Technologies**
Weitergabe und Vervielfaeltigung dieser Unterlage, Verwertung und Mitteilung ihres Inhalts nicht gestattet, soweit nicht ausdrecklich zugestanden. Zuwiderhandlungen verpflichten zu Schadenersatz.

Bemerkung - Note
Für Trockenlauf geeignet!
Use without coolant fluid allowed!

Technische Daten - technical data

Weight	= 1.902 [kg]
Torque max. (M1/M2)	= 25 / 25 [Nm]
Speed max. (n1/n2)	= 6000 / 6000 [1/min]
Gear ratio (i)=n1:n2	= 1:1
Pressure (pmax)	= 70 [bar]

Benennung - Title
Axial Bohr und Fräskopf
Axial drilling and milling head

EWS Tool Technologies
EWS Weigle GmbH & Co. KG
Maybachstr. 1
D-73066 Uthingen
www.ews-tools.de

Nr. - No.
40.4425NTY3IKCIM

Technische Aenderungen vorbehalten!
Subject to technical modifications!

IDENT: DEWS091059	REV: -/B
MNR.	197694

