

Trifix Anzugsdrehmoment 25 Nm
 Trifix clamping torque 25 Nm

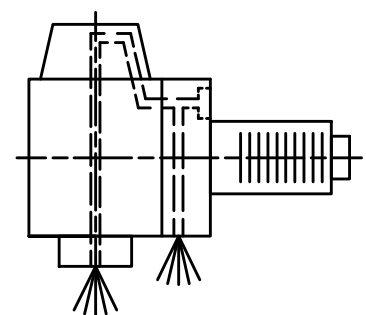
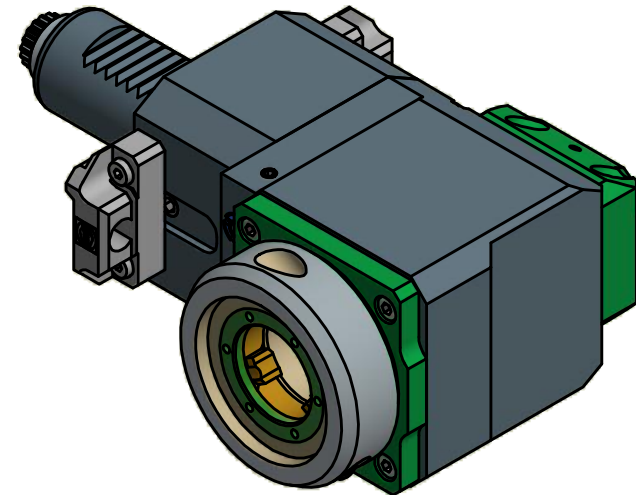
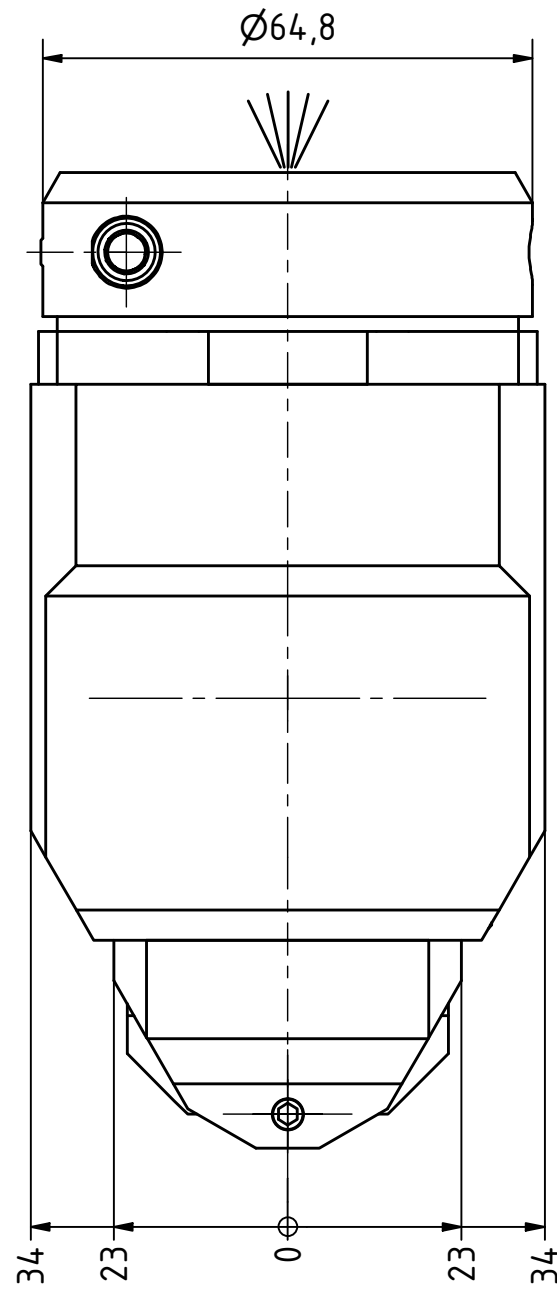
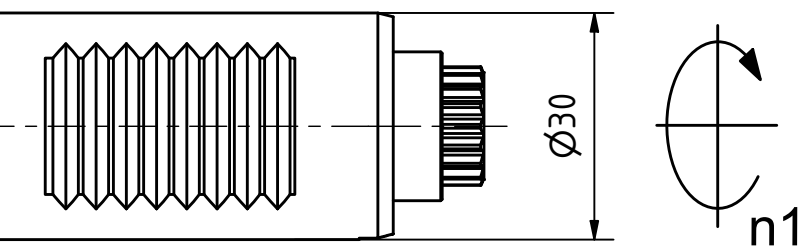

Innen- und Aussenkuehlung / Inside and outside coolant supply
 Kein Trockenlauf / No dry run
 Kuehlmittelfiltrierung<50µ / coolant filtration<50µ

Copyright **EWS Tool Technologies**
 Weitergabe und Vervielfaeltigung dieser Unterlage,
 Verwertung und Mitteilung ihres Inhalts nicht
 gestattet, soweit nicht ausdrecklich zugestanden.
 Zuwiderhandlungen verpflichten zu Schadenersatz.

<p>Bemerkung - Note</p> <p>Nicht ohne Kuehlmittel betreiben! <i>Not for use without coolant-fluid!</i></p>	<p>Technische Daten - technical data</p> <p>Weight = 4.518 [kg] Torque max. (M1/M2) = 25 / 25 [Nm] Speed max. (n1/n2) = 8000 / 8000 [1/min] Gear ratio (i)=n1:n2 = 1:1 Pressure (pmax) = 70 [bar]</p>	<p>Benennung - Title</p> <p>EWS <small>EWS Weigele GmbH & Co. KG Maybachstr. 1 D-73066 Uehingen www.ews-tools.de</small></p> <p>Technische Aenderungen vorbehalten! <i>Subject to technical modifications!</i></p> <p>IDENT: DEWS04.7579</p> <p>Nr. - No. 60.30VX3GT300LIKTF</p>	<p>REV: -/A</p> <p>MNR. 208330</p>	
---	---	--	---	---