

Spannzange / collet ER20 DIN6499
 Spannbereich / clamping range: 1,0 - 13,0

Gewindebohrzange / tapping collet
 ET-1-20 M2-M6

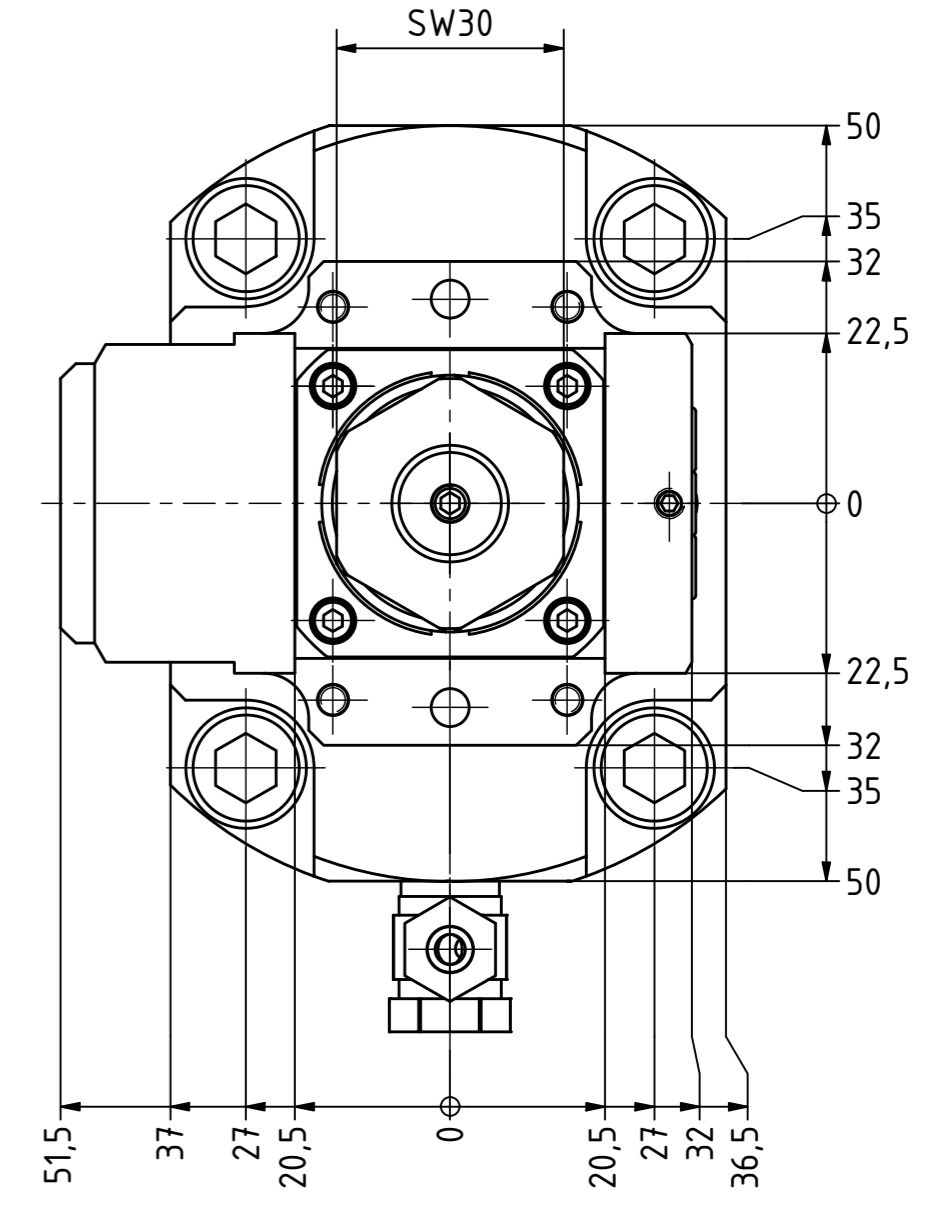

Platzverhältnisse / space conditions
Muratec MD60 / MD120

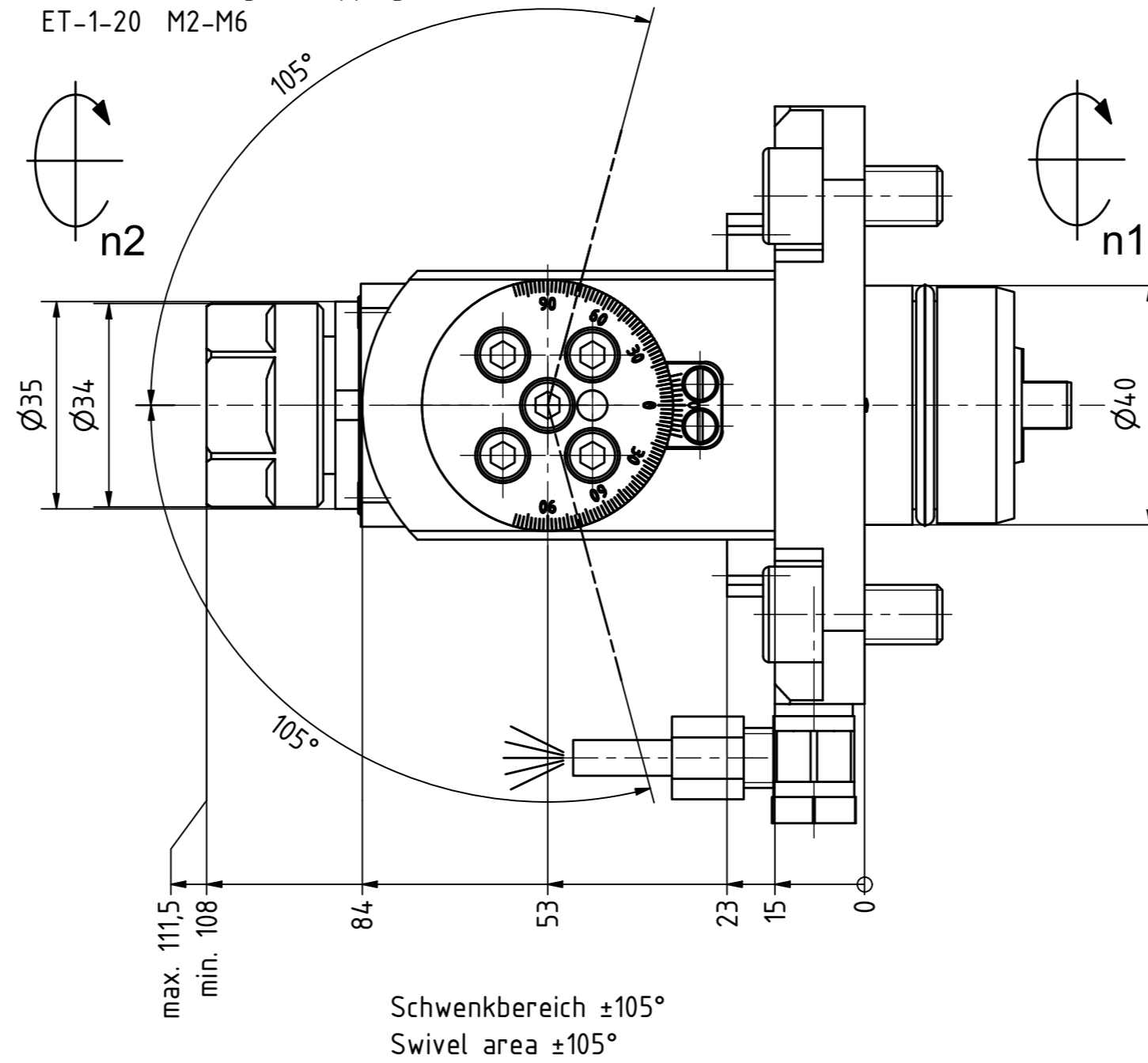
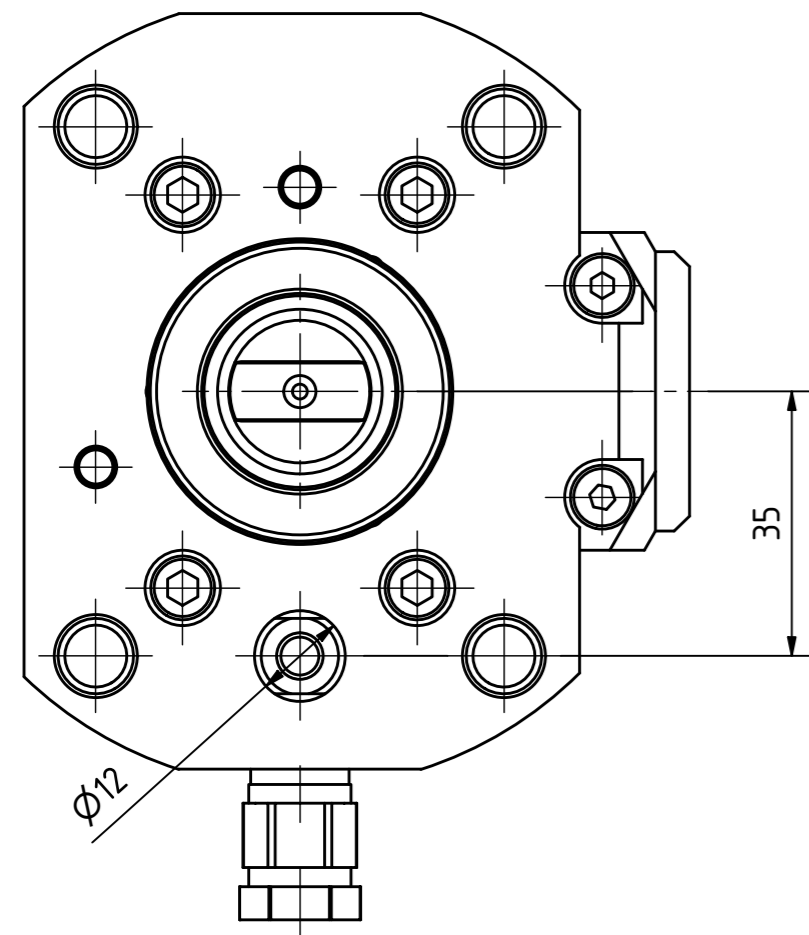
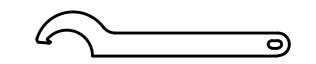
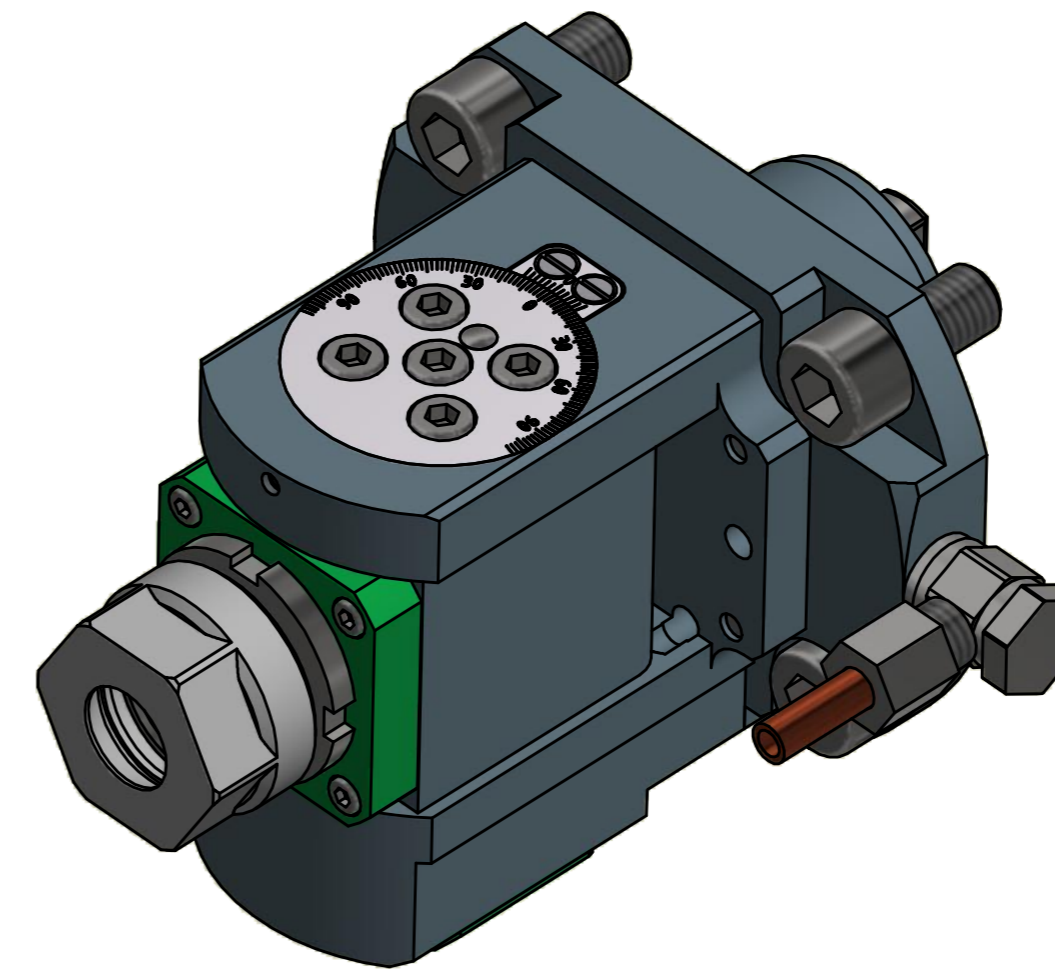
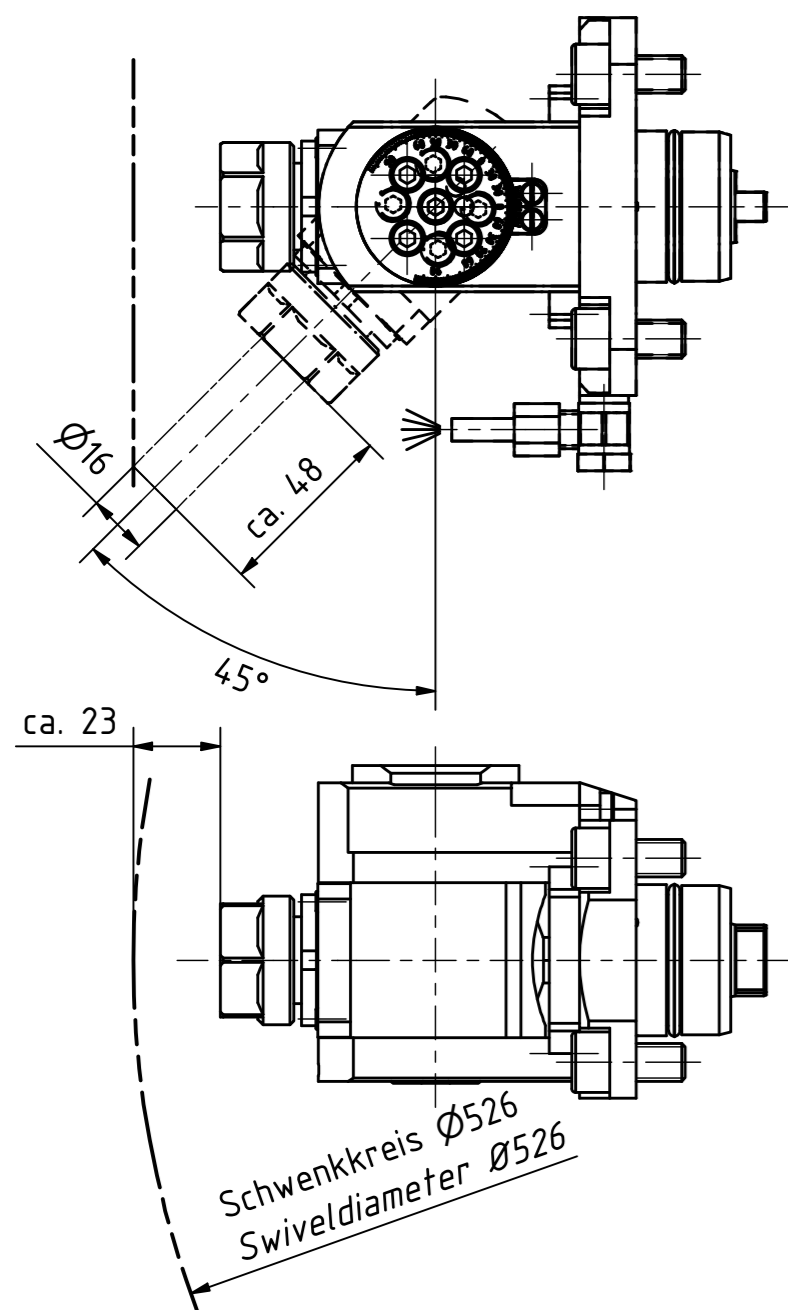

Hakenschlüssel
 mit Nase
 Hook wrench with
 nose end
 DIN1810 A 34x36

Copyright **EWS Tool Technologies**
 Weitergabe und Vervielfältigung dieser Unterlage,
 Verwertung und Mitteilung ihres Inhalts nicht
 gestattet, soweit nicht ausdrücklich zugestanden.
 Zuwiderhandlungen verpflichten zu Schadenersatz.

Bemerkung - Note

Technische Daten - technical data

Weight = 3.236 [kg]
 Torque max. (M1/M2) = 16 / 16 [Nm]
 Speed max. (n1/n2) = 6000 / 6000 [1/min]
 Gear ratio (i)=n1:n2 = 1:1

Benennung - Title

Schwenkkopf
 Swivel head



Technische Änderungen vorbehalten!
 Subject to technical modifications!
 IDENT: DEWS077637

Nr. - No.
 63.4020MD60

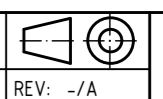

QR