

Spannzange / collet ER40 DIN6499
 Spannbereich / clamping range: 3,0 - 26,0

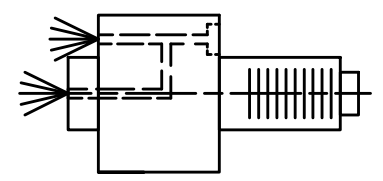

Innen- und Aussenkuehlung / Inside and outside coolant supply
 Kuehlmittelfiltrierung 50μ / coolant filtration 50μ

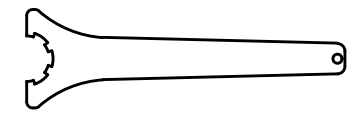
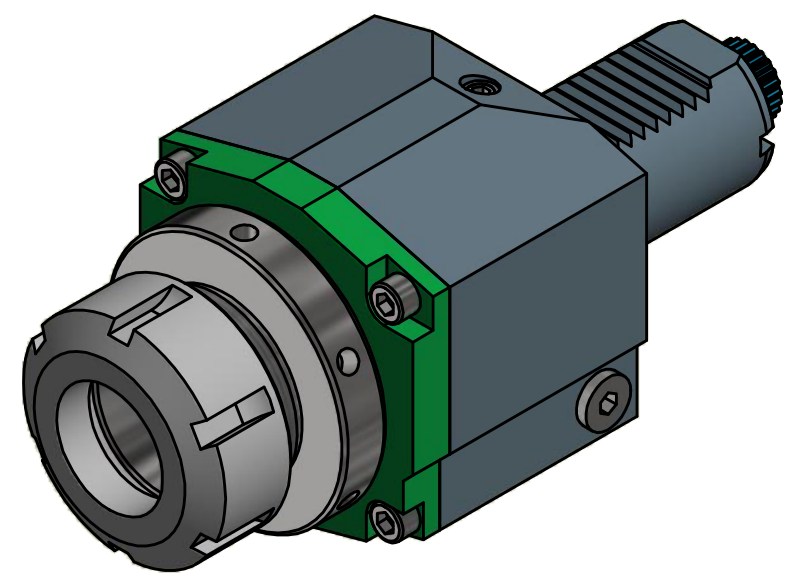

Spannzangenschlüssel
 Clamping wrench
 240

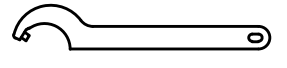

Hakenschlüssel
 mit Zapfen
 Hook wrench
 with fixed pin
 DIN1810 B 68x75

Copyright **EWS Tool Technologies**
 Weitergabe und Vervielfaeltigung dieser Unterlage,
 Verwertung und Mitteilung ihres Inhalts nicht
 gestattet, soweit nicht ausdrecklich zugestanden.
 Zuwiderhandlungen verpflichten zu Schadenersatz.

Bemerkung - Note
 Für Trockenlauf geeignet!
 Use without coolant fluid allowed!

Technische Daten - technical data	
Weight	= 4.642 [kg]
Torque max. (M1/M2)	= 50 / 50 [Nm]
Speed max. (n1/n2)	= 6000 / 6000 [1/min]
Gear ratio (i)=n1:n2	= 1:1
Pressure (pmax)	= 70 [bar]

Benennung - Title
Axial Bohr und Fräskopf
 Axial drilling and milling head

EWS Tool Technologies
 EWS Weigele GmbH & Co. KG
 Maybachstr. 1
 D-73066 UHINGEN
 www.ews-tools.de

Nr. - No.
40.4040CTXIKC

Technische Aenderungen vorbehalten! Subject to technical modifications!	IDENT: DEWS079045
REV: -/A	MNR. 215015

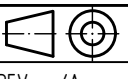

QR