

Hakenschlüssel  
mit Zapfen  
Hook wrench  
with fixed pin  
DIN1810 B 40x42

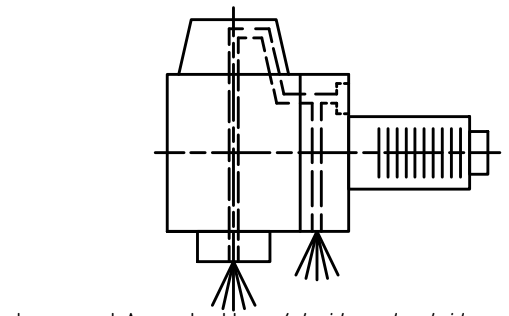

Innen- und Aussenkuehlung / Inside and outside coolant supply  
Kuehlmittelfiltrierung <math>< 50\mu</math> / coolant filtration <math>< 50\mu</math>

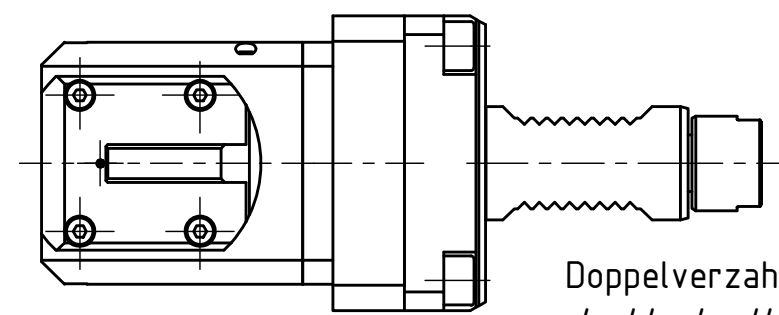

Doppelverzahnung Lizenz Traub  
double tooth system licence Traub

Copyright **EWS Tool Technologies**  
Weitergabe und Vervielfaeltigung dieser Unterlage,  
Verwertung und Mitteilung ihres Inhalts nicht  
gestattet, soweit nicht ausdrecklich zugestanden.  
Zuwiderhandlungen verpflichten zu Schadenersatz.

Bemerkung - Note  
Für Trockenlauf geeignet!  
Use without coolant fluid allowed!

| Technische Daten - technical data |                        |
|-----------------------------------|------------------------|
| Weight                            | = 4.965 [kg]           |
| Torque max. (M1/M2)               | = 24 / 12 [Nm]         |
| Speed max. (n1/n2)                | = 6000 / 12000 [1/min] |
| Gear ratio (i)=n1:n2              | = 1:2                  |
| Pressure (pmax)                   | = 70 [bar]             |

Benennung - Title  
**Radial Bohr und Fräskopf**  
Radial drilling and milling head

**EWS** Tool Technologies  
EWS Weigle GmbH & Co. KG  
Maybachstr. 1  
D-73066 UHINGEN  
www.ews-tools.de

|  |          |
|--|----------|
| Technische Aenderungen vorbehalten!<br>Subject to technical modifications! |          |
| IDENT: DEWS083666  | REV: -/A |
| Nr. - No.  | MNR.     |
| 60.3020G300RLIKDI1W-COB  | 215950   |

