

Capto C3-Aufnahme  
Capto C3-Adaptor

Anlagefläche  
contact surface

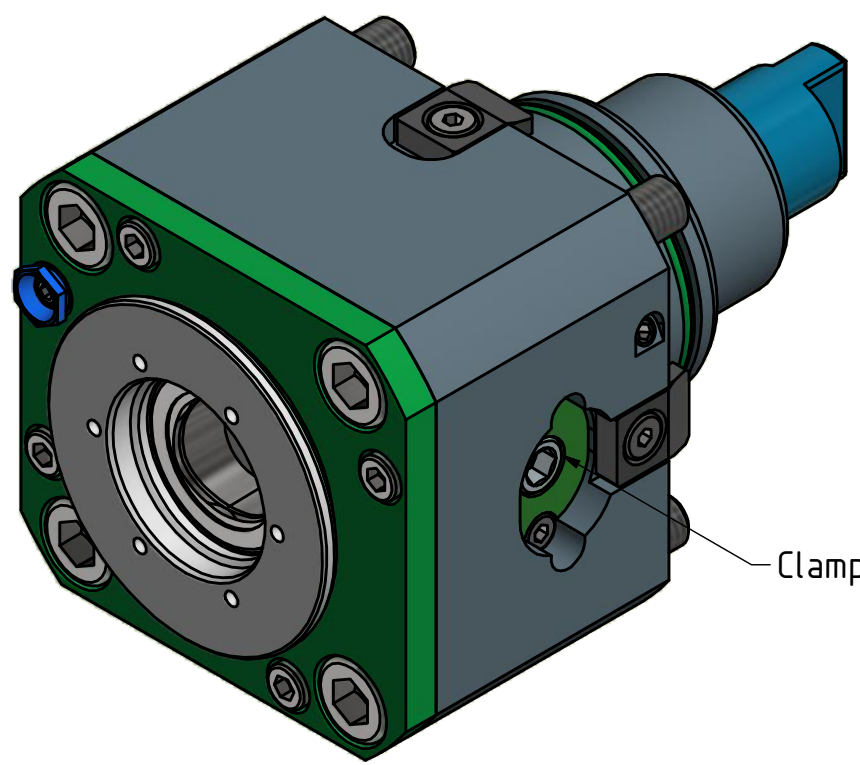

Clamping torque 35 Nm

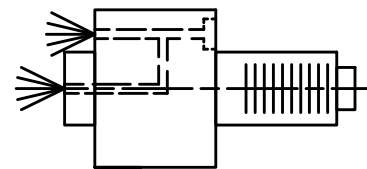

Innen- und Aussenkuehlung / Inside and outside coolant supply  
Kuehlmittelfiltrierung <math>50\mu</math> / coolant filtration <math>50\mu</math>

Copyright **EWS Tool Technologies**  
Weitergabe und Vervielfaeltigung dieser Unterlage,  
Verwertung und Mitteilung ihres Inhalts nicht  
gestattet, soweit nicht ausdruendlich zugestanden.  
Zuwiderhandlungen verpflichten zu Schadenersatz.

<p>Bemerkung - Note</p> <p>Für Trockenlauf geeignet! Use without coolant fluid allowed!</p>	<p>Technische Daten - technical data</p> <p>Weight = 3.845 [kg] Torque max. (M1/M2) = 50 / 50 [Nm] Speed max. (n1/n2) = 12000 / 12000 [1/min] Gear ratio (i)=n1:n2 = 1:1 Pressure (pmax) = 70 [bar]</p>	<p>Benennung - Title</p> <p>Axial Bohr und Fräskopf Axial drilling and milling head</p>	<p><b>EWS</b> Tool Technologies</p> <p><small>EWS Weigle GmbH &amp; Co. KG Maybachstr. 1 D-73066 UHINGEN www.ews-tools.de</small></p>	<p>Technische Aenderungen vorbehalten! Subject to technical modifications!</p> <p>IDENT: DEWS098631</p>	<p></p> <p>REV: -/A</p> <p>MNR.</p> <p>218094</p>	<p><b>QR</b></p>
<p>Nr. - No.</p> <p>40.55C3VL2IKCHSD12</p>		<p>218094</p>		<p>218094</p>		