

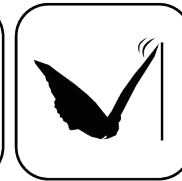

Ceramic Seal



Butterfly Seal



Tech Details

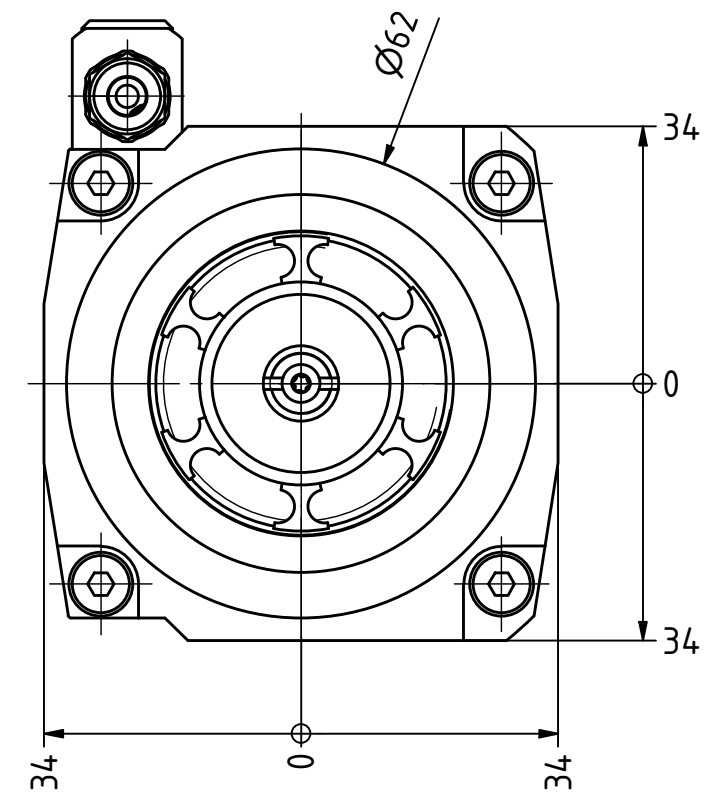
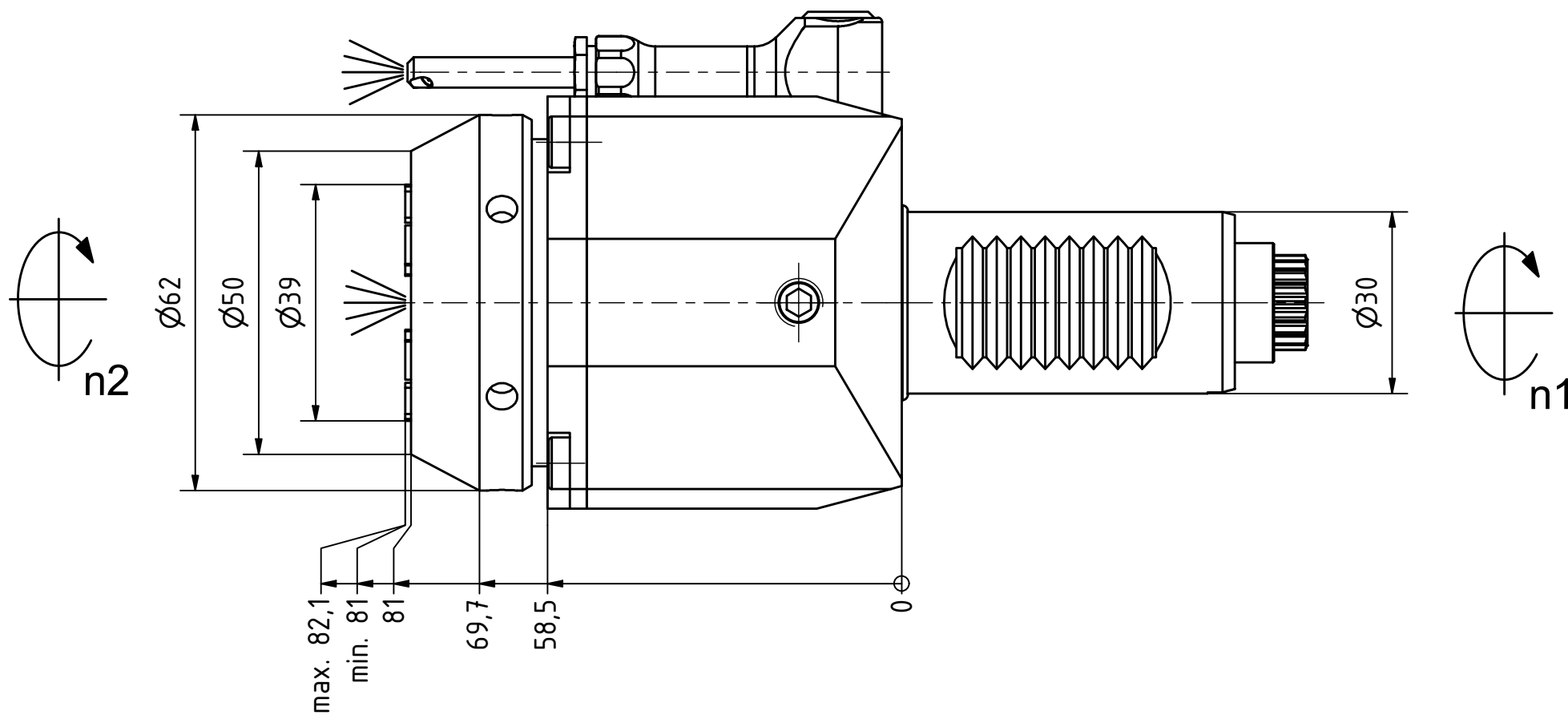

Spannzange / collet ER32 DIN6499
Spannbereich / clamping range: 2,0 - 20,0

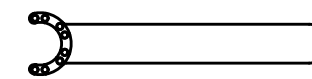

Spannzangenschlüssel für innenliegende Mutter
Clamping wrench for internal collet
EA 32 K



Hakenschlüssel mit Zapfen
Hook wrench with fixed pin
DIN1810 B 58x62

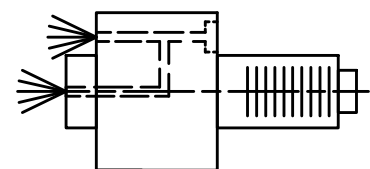
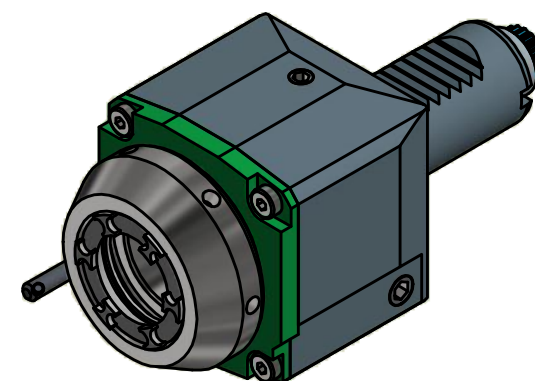

Innen- und Aussenkuehlung / Inside and outside coolant supply
Kuehlmittelfiltrierung <math>< 50\mu</math> / coolant filtration <math>< 50\mu</math>

Copyright **EWS Tool Technologies**
Weitergabe und Vervielfaeltigung dieser Unterlage, Verwertung und Mitteilung ihres Inhalts nicht gestattet, soweit nicht ausdrecklich zugestanden. Zuwiderhandlungen verpflichten zu Schadenersatz.

Bemerkung - Note
Für Trockenlauf geeignet!
Use without coolant fluid allowed!

Technische Daten - technical data	
Weight	= 2.269 [kg]
Torque max. (M1/M2)	= 32 / 32 [Nm]
Speed max. (n1/n2)	= 8000 / 8000 [1/min]
Gear ratio (i)=n1:n2	= 1:1
Pressure (pmax)	= 70 [bar]

Benennung - Title
Axial Bohr und Fräskopf
Axial drilling and milling head

EWS Tool Technologies
EWS Weigle GmbH & Co. KG
Maybachstr. 1
D-73066 UHINGEN
www.ews-tools.de
Nr. - No.
40.3032CTXIKCIM

Technische Aenderungen vorbehalten!
Subject to technical modifications!
IDENT: DEWS105756
REV: -/B
MNR.
219363

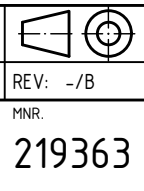

QR