

Spannzange / collet ER25 DIN6499
Spannbereich / clamping range: 1,0 - 16,0

Gewindebohrzange / tapping collet
ET-1-25 M3-M12

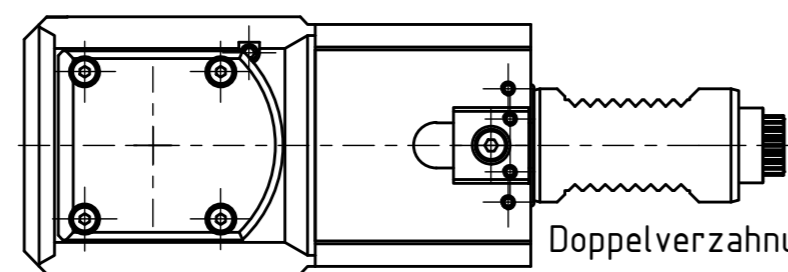

Doppelverzahnung Lizenz Traub
double tooth system licence Traub

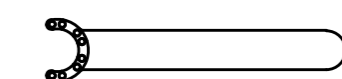
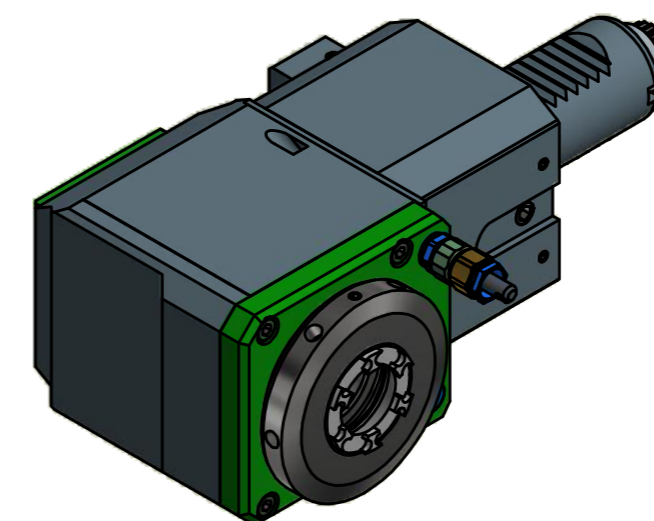

Spannzangenschlüssel für
innenliegende Mutter
Clamping wrench for
internal collet
EA 25 K

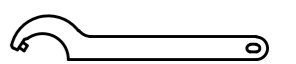

Hakenschlüssel
mit Zapfen
Hook wrench
with fixed pin
DIN1810 B 58x62
EA 25 K

Copyright **EWS Tool Technologies**
Weitergabe und Vervielfältigung dieser Unterlage,
Verwertung und Mitteilung ihres Inhalts nicht
gestattet, soweit nicht ausdrücklich zugestanden.
Zuwendungen verpflichten zu Schadenersatz.

Bemerkung - Note	Technische Daten - technical data Weight = 4,478 [kg] Torque max. (M1/M2) = 32 / 32 [Nm] Speed max. (n1/n2) = 8000 / 8000 [1/min] Gear ratio (i)=n1:n2 = 1:1	Benennung - Title Radial Bohr und Fräskopf Radial drilling and milling head	<div style="display: flex; justify-content: space-between;"> <div data-bbox="2226 1915 2463 2043"> EWS Weigle GmbH & Co. KG Maybachstr. 1 D-73066 Ulm/ingen www.ews-tool.de </div> <div data-bbox="2463 1915 2700 2043"> Technische Änderungen vorbehalten! Subject to technical modifications! IDENT: DEWS096528 Nr. - No. 60.3025LCTXRLIM#01 </div> <div data-bbox="2700 1915 2908 2043"> REV: -/A MNR. 219366 <div style="font-size: 2em; font-weight: bold; text-align: center;">QR</div> </div> </div>
------------------	--	---	---