

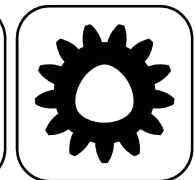

Butterfly Seal



Polygon Joint



Tech Details

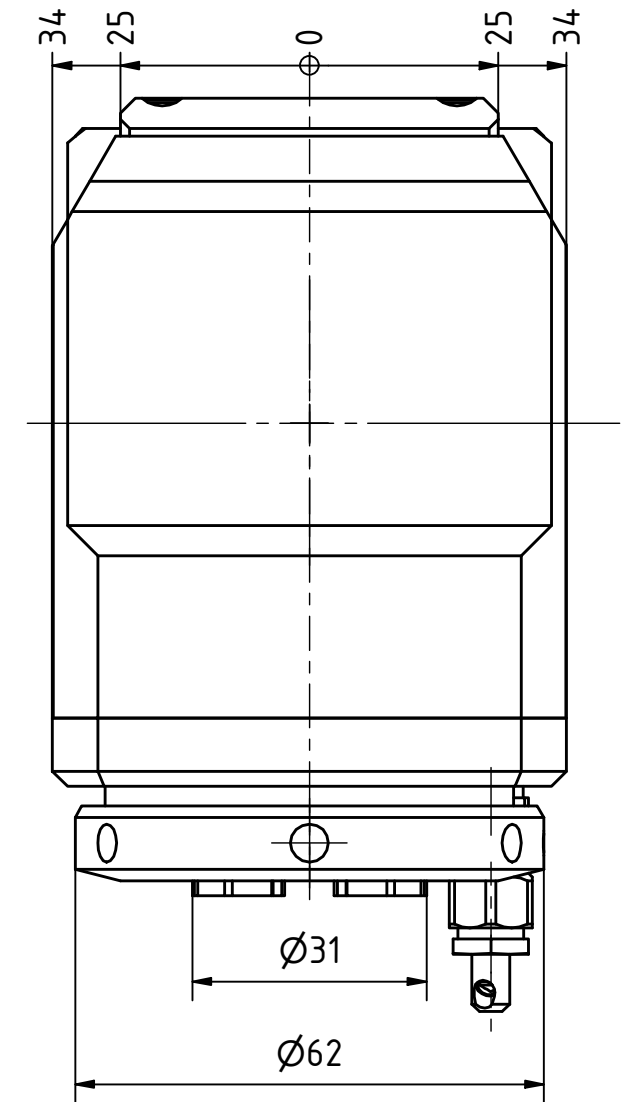
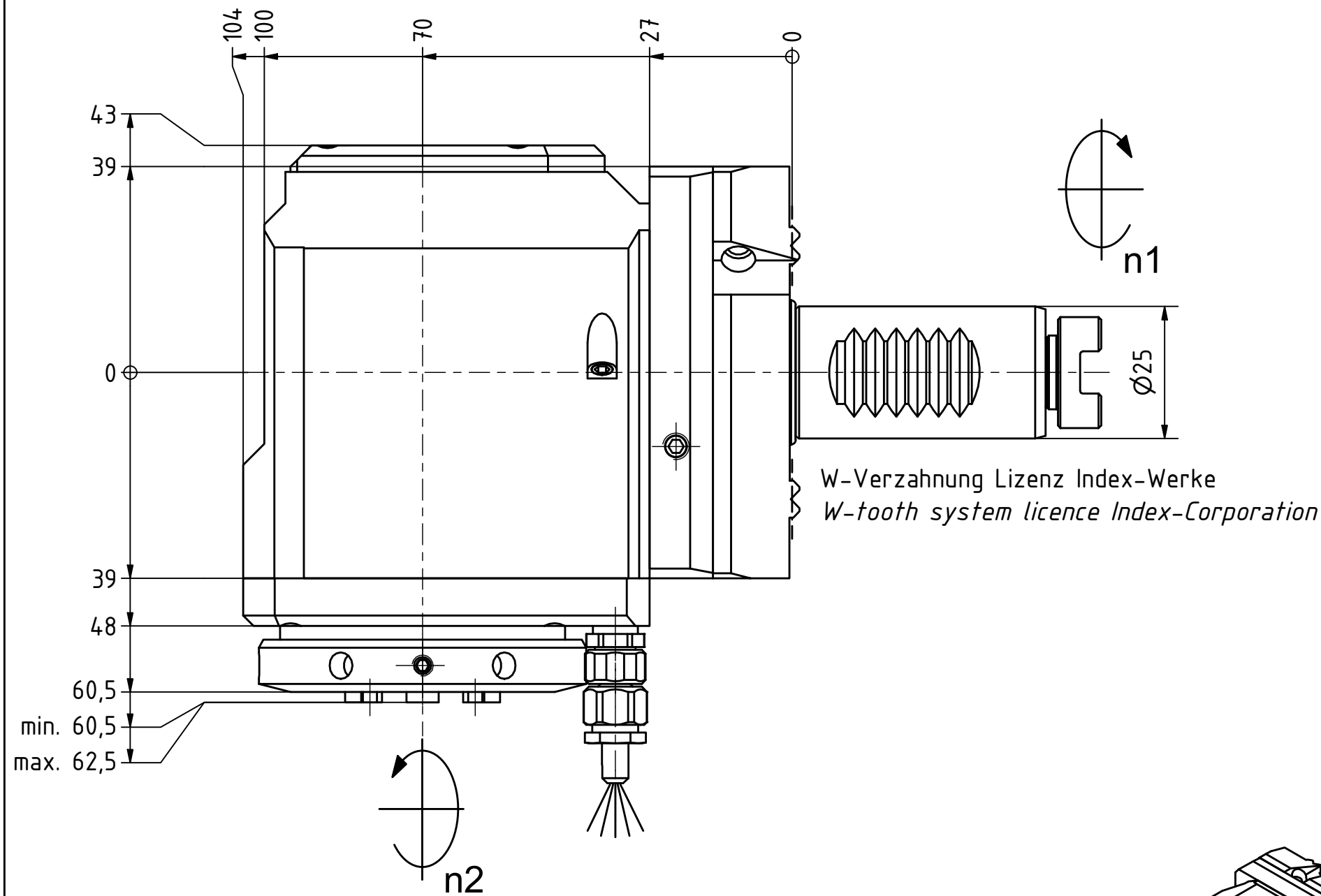

Spannzange / collet ER25 DIN6499
Spannbereich / clamping range: 1,0 - 16,0

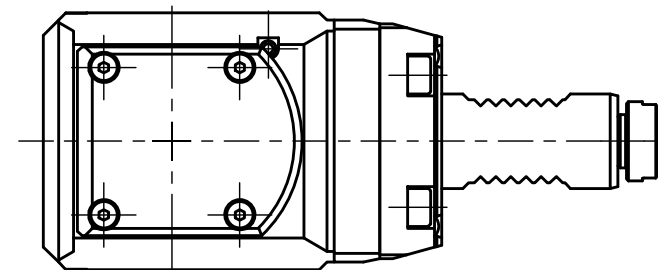

Doppelverzahnung Lizenz Traub
double tooth system licence Traub

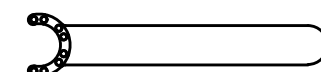
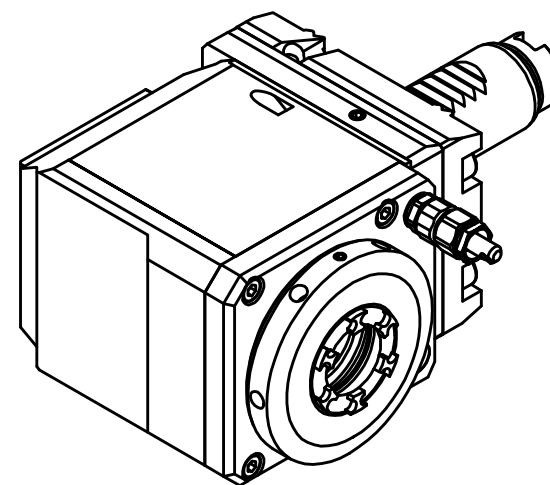

Spannzangenschlüssel für
innenliegende Mutter
Clamping wrench for
internal collet
EA 25 K

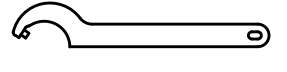

Hakenschlüssel
mit Zapfen
Hook wrench
with fixed pin
DIN1810 B 58x62

Copyright **EWS Tool Technologies**
Weitergabe und Vervielfältigung dieser Unterlage,
Verwertung und Mitteilung ihres Inhalts nicht
gestattet, soweit nicht ausdrücklich zugestanden.
Zuwendungen verpflichten zu Schadenersatz.

Bemerkung - Note

Technische Daten - technical data

Weight = 3.900 [kg]
Torque max. (M1/M2) = 25 / 25 [Nm]
Speed max. (n1/n2) = 8000 / 8000 [1/min]
Gear ratio (i)=n1:n2 = 1:1

Benennung - Title

Radial Bohr und Fräskopf
Radial drilling and milling head



EWS Weigle GmbH & Co. KG
Maybachstr. 1
D-73066 UHINGEN
www.ews-tools.de

Technische Änderungen vorbehalten!
Subject to technical modifications!

IDENT: DEWS102113

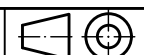

REV: -/A

Nr. - No.

60.2525G200RLWIM#01

MNR.

220036

QR