

Product Datasheet model uvex pure-fit 9145 015

**UVEX ARBEITSSCHUTZ GMBH, Würzburger Str. 181-189,
D-90766 Fürth**

1. Product Characteristics

- reduced to the max - pure, ultralight safety spectacle with innovative side arm concept weighing only 19 grams
- frameless lens design for a wide field of vision
- x-tended sideshield offers additional protection from hazards
- flexible side arms deliver the perfect secure, pressure-free fit
- nose bridge designed for all-day comfort
- robust polycarbonate lens
- UV400 – 100 % protection against dangerous UVA and UVB radiation up to 400 nm
- metal-free

2. Technical Details Body

Side arms

Material	PC
Features	flexible side arms
Colour	transparent

Marking

Manufacturer 's ID code	W
Applicable EN norm	166
Impact resistance	F (45 m/s)
Resistance to high speed particles at extremes of temperature	T
Conformity symbol	CE

3. Technical Details Lens



Material	PC
Thickness	1.91 mm at PD
Coating	uncoated
Colour	clear
UV protection	UV400

Marking

Filter	2C-1,2 (EN 170)
Manufacturer 's ID code	W
Optical class	1
Impact resistance	F (45 m/s)
Resistance to high speed particles at extremes of temperature	T
Conformity symbol	CE
Factory symbol	

4. Logistical Information

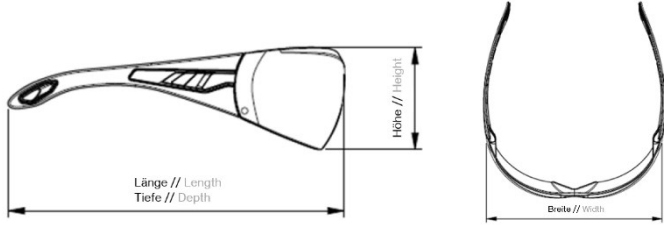
Product

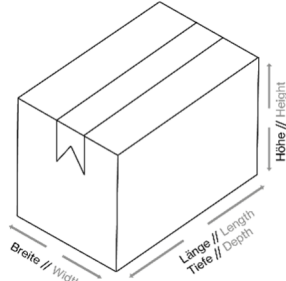
Weight	19g	
Dimensions (L x W x B) in approx. mm	 <p style="text-align: right;">picture only for reference</p>	
	94 x 142 x 46	
	Packing unit 1	Packing unit 2
EAN Code	4031101927978	4031101927978
Quantity in pcs.	1	75
Dimensions (L x W x H) in approx. mm	 <p style="text-align: center;">picture only for reference</p>	
	160 x 230 x 57	440 x 345 x 318
Net weight in approx. g	19	1,425
Gross weight in approx. g	48	4,055
Country of Origin	Germany	

5. Miscellaneous

Standards	EN 166 + EN 170
PPE Category	Category II