



KL-0029-200 (E/K) + KL-0029-1.. Removal and Mounting Aid for McPherson Suspension Struts



Operating instructions EN
⚠ Read and understand before use!



www.gedore-automotive.com

GEDORE Automotive GmbH

Breslauer Straße 41
78166 - Donaueschingen
Postfach 1329
78154 Donaueschingen - GERMANY

☎ +49 (0) 771 / 8 32 23-0
☎ +49 (0) 771 / 8 32 23-90
✉ info.gam@gedore.com
🌐 gedore-automotive.com

GEDORE TOOLS, INC.

Only for USA, Canada & Mexico / Sólo para EE.UU., Canadá y México
Seulement pour les USA, le Canada et le Mexique
7187 Bryhawke Circle, Suite 700
North Charleston, SC 29418, USA

☎ +1-843 / 225 50 15
☎ +1-843 / 225 50 20
✉ info@gedoretools.com
🌐 gedore.com

Version 10/2022

0029-200+1..Serie_EN220802.indd



ENGLISH

EN

EN

Address of the manufacturer

GEDORE Automotive GmbH

Breslauer Straße 41 // 78166 Donaueschingen - GERMANY

☎ +49 (0)771/83223-71 // ✉ info.gam@gedore.com

Imprint

In the course of improvement and adaptation to the state of the art, we reserve the right to make changes with regard to appearance, dimensions, weights and properties, and performance.

This does not imply any claim to correction or subsequent delivery of already delivered products. Deletions can be made at any time without any legal claim arising.

Instructions for use and safety are not binding. They never substitute for any legal or trade association regulations.

We do not accept any liability for printing errors.

Any reproduction, in whole or in part, requires the prior written consent of **GEDORE Automotive GmbH**.

All rights reserved worldwide.

© Copyright by **GEDORE Automotive GmbH** Donaueschingen (GERMANY)

We refer to our general terms and conditions, which can be found in the imprint at:

www.gedore-automotive.com



Contents

1. READ AND UNDERSTAND FOR YOUR SAFETY	4
1.1 Target group	4
1.2 Obligations of the owner	4
1.3 Intended use	4
1.4 Reasonably foreseeable misuse.....	4
1.5 Personal protective equipment	5
1.6 Labelling of the warnings.....	5
1.7 Basic warnings.....	5
1.8 Basic safety instructions	6
1.9 Work environment	7
1.10 Emissions	7
1.11 Maintenance.....	7
1.12 Troubleshooting.....	7
2. PRODUCT DESCRIPTION	8
2.1 KL-0029-200 (E/K) - Removal and mounting aid for McPherson suspension struts	8
2.2 Scope of delivery.....	8
2.3 Specifications	8
2.4 Supplementary kits for the removal and mounting aid	9
3. PREPARATION	13
3.1 Checking the scope of delivery	13
3.2 Preparing the removal and mounting aid.....	13
3.3 Preparing the vehicle	13
4. TYPICAL APPLICATION	14
4.1 Placing the basic tool to the suspension strut...	
4.1.1 ...in combination with KL-0029-111	14
4.1.2 ...in combination with KL-0029-120 A	15
4.1.3 ...in combination with KL-0029-122.....	16
4.1.4 ...in combination with KL-0029-130 A	17
4.1.5 ...in combination with KL-0029-150.....	18
4.1.6 ...in combination with KL-0029-152.....	19
4.1.7 ...in combination with KL-0029-160 A	20
4.1.8 ...in combination with KL-0029-170.....	21
4.2 Dismounting a suspension strut	22
4.3 Mounting a suspension strut.....	24
5. CARE / STORAGE	25
6. REPAIR	25
7. INDIVIDUAL PART OVERVIEW	26
8. ENVIRONMENTALLY COMPLIANT DISPOSAL	26

1. READ AND UNDERSTAND FOR YOUR SAFETY



Read and understand these operating instructions **before using** the removal and mounting aid for McPherson suspension struts, and observe all safety and warning instructions! Misuse can result in **DEATH** or **SEVERE INJURIES**! These operating instructions are an integral part of the removal and mounting aid. Keep them at a safe place for future reference, and always pass them on to subsequent users of the removal and mounting aid! The removal and mounting aid complies with the recognised rules of technology as well as the relevant safety regulations!

1.1 Target group

These operating instructions are **exclusively** intended for skilled personnel in specialised motor vehicle workshops!

The removal and mounting aid **may only be** used by skilled personnel in specialised motor vehicle workshops who are familiar with the basic regulations on work safety and accident prevention!

✔ **Never** allow unauthorised, inexperienced persons, minors and children, or persons with limited physical, sensory, and mental abilities to use the removal and mounting aid!

1.2 Obligations of the owner

Pursuant to the German Ordinance on Industrial Safety and Health (*BetrSichV*), employers are obliged to provide their employees with safe work equipment in accordance with the recognised rules of technology and the relevant safety regulations!

✔ The owner of the removal and mounting aid **must** ensure that **only** trained personnel in specialised vehicle workshops use the removal and mounting aid!

✔ The owner of the removal and mounting aid **must** ensure that the instructions for use are available to the user and that the user has completely read and understood the instructions for use **before** using the removal and mounting aid!

✔ The owner of the removal and mounting aid **must** ensure that the user is familiar with the basic regulations on work safety and accident prevention, and that the personal protective equipment is available to him!

1.3 Intended use

The removal and mounting aid ...

✔ **may only** be used for compressing McPherson struts.

✔ **may only be** used in combination with the vehicle-specific supplementary kits!

✔ **may only** be used on vehicles as specified in **Chapter 2 - Product description**!

✔ **may only** be used up to a **max. load of 17500 Newton**!

✔ **may only** be used by hand with muscle power with a manual drive!

✔ **may only** be used with **GEDORE Automotive** genuine spare parts and accessories!

✔ **may only** be used in the way described in these operating instructions!

⚠ Any other use can result in **DEATH** or **SEVERE INJURIES**!

1.4 Reasonably foreseeable misuse

The removal and mounting aid ...

✔ **must never** be used for compressing coil springs and struts other than that intended for it!

✔ **must never** be used for disassembling a strut!

✔ **must never** be used without the components required for compressing!

✔ **must never** be used together with an impulse or impact screwdriver!

✔ **must never** be used with a machine-operated drive or a drive other than that intended for it!

✔ **must never** be used for batch processing with many compressing processes within a few minutes!

✔ **must never** be used with a bridged, modified, or removed safety device!

✔ **must never** be modified, converted, or used for other purposes without authorisation!

⚠ Use the wheel hub extractor **always** as intended. Any other use can result in **DEATH** or in **SEVERE INJURIES**!

1.5 Personal protective equipment

For your safety, **always** wear personal protective equipment when using the removal and mounting aid! The removal and mounting aid can bring about mechanical hazards such as crushing, cutting, and shock injuries.



Always wear **EYE PROTECTION** (for example to DIN EN 166, OSHA 29 CFR 1910.133, ANSI Z87) when using the removal and mounting aid to protect yourself against flying parts or particles!

When using the removal and mounting aid, flying parts or particles can cause **SEVERE INJURIES** to your **eyes!**



Always wear **PROTECTIVE GLOVES** (for example to DIN EN 388, OSHA 29 CFR 1910.138, ANSI 105) when using the removal and mounting aid to protect yourself against sharp edges and crushing between parts!

When working with the removal and mounting aid, sharp edges and crushing between parts can cause **SEVERE INJURIES** to your **hands!**



Always wear **SAFETY SHOES** (for example to DIN EN ISO 20345, OSHA 29 CFR 1910.136, ANSI Z41) when using the removal and mounting aid to protect yourself against dropping parts!

When working with the removal and mounting aid, dropping parts can cause **SEVERE INJURIES** to your **feet and toes!**

EN

1.6 Labelling of the warnings

Warnings warn of potential **hazards**. **Always** observe these warnings to avoid **DEATH** or **INJURIES!**

For better differentiation, warnings in these operating instructions are classified as follows:

Warning sign	Meaning
WARNING	Indicates a hazardous situation which, if not avoided, could cause DEATH or SEVERE INJURIES .
CAUTION	Indicates a hazardous situation which, if not avoided, could cause MODERATE or MINOR INJURIES .
ATTENTION	Indicates a situation which, if not avoided, can cause damage to the tool or an object in its vicinity.
	Note on important information and useful tips.

1.7 Basic warnings

WARNING - Danger to life from MISUSE

MISUSE can cause the removal and mounting aid to slip, break and thus drop, or be hurled about. This can cause **DEATH** or **SEVERE INJURIES!**

- Read and understand these operating instructions **before using** the removal and mounting aid, and observe all safety and warning instructions for **safe use!**
- Always** work with the removal and mounting aid in accordance with the basic regulations on work safety and accident prevention!
- Only** use the removal and mounting aid as intended and as described in these operating instructions!
- Always** observe the vehicle-specific application procedures in the repair guide of the vehicle manufacturer!
- Never** use the removal and mounting aid if it is damaged or has loose parts or unauthorised modifications!
- Never** use the removal and mounting aid with a machine-operated drive; **only** drive it by hand with muscle power with a manual drive!
- Never** use the removal and mounting aid for batch processing with many compressing operations within a few minutes!
- Never** open the piston rod nut on the removal and mounting aid or disassemble the suspension strut in any way while using the removal and mounting aid!
- Always** wear your personal protective equipment (*safety goggles, protective gloves, safety shoes*) during work!
- Never** hit the removal and mounting aid with a hammer or anything similar!

⚠ WARNING - Danger to life from OVERLOAD

OVERLOAD can cause the removal and mounting aid to slip, break and thus drop, or be hurled about. This can cause **DEATH** or **SEVERE INJURIES!**

- ✔ **Never** exceed the **maximum loading capacity** of the removal and mounting aid!
- ✔ **Never** use the removal and mounting aid if it is damaged or has loose parts or unauthorised modifications!
- ✔ **Never** use the removal and mounting aid with an impulse or impact wrench!
- ✔ **Never** use the removal and mounting aid with a machine-operated drive; **only** drive it by hand with muscle power with a manual drive!
- ✔ **Never** use the removal and mounting aid for batch processing with many compressing operations within a few minutes!
- ✔ **Always** wear your personal protective equipment (*safety goggles, protective gloves, safety shoes*) during work!

⚠ WARNING - Danger of injury from FALLING

There is a risk of the removal and mounting aid **DROPPING** during preparation and use (overhead, for example). This can cause **SEVERE INJURIES!**

- ✔ **Always** make sure that the removal and mounting aid is securely attached to the suspension strut!
- ✔ Avoid dropping the removal and mounting aid tool **at all costs**, especially when it is under load!
- ✔ **Never** leave the removal and mounting aid unattended in loaded condition on the suspension strut!
- ✔ Put down the removal and mounting aid **safely** to prevent it from dropping (for example on a workbench)!
- ✔ **Always** wear your personal protective equipment (*safety goggles, protective gloves, safety shoes*) during work!

ATTENTION - Risk of DAMAGE

The vehicle, the suspension strut, and the removal and mounting aid can be **damaged**.

- ✔ **Always** observe the installation position of the suspension strut specified by the vehicle manufacturer!
- ✔ **Always** observe vehicle-specific application procedures in the repair guide of the vehicle manufacturer.
- ✔ **Prior to each use**, check the moving parts and the spindle of the removal and mounting aid for sufficient lubrication. If necessary, lubricate them only with molybdenum disulphide paste (for example **GEDORE Automotive - KL-0014-0030!**)
- ✔ **Never** use the removal and mounting aid for batch processing with many compressing operations within a few minutes!
- ✔ **Never** clamp the removal and mounting aid in a vice.

1.8 Basic safety instructions

For your safety, **always** observe the following safety precautions when using the removal and mounting aid in order to avoid injuries and material damage caused by misuse or unsafe handling.

- ✔ Read and understand these operating instructions **before using** the removal and mounting aid, and observe all safety and warning instructions for **safe use!**
- ✔ **Always** observe the vehicle-specific application procedures in the repair guide of the vehicle manufacturer!
- ✔ **Always** work with the removal and mounting aid in accordance with the basic regulations on work safety and accident prevention!
- ✔ **Never** use the removal and mounting aid when you are tired or under the influence of alcohol, drugs, or medication!
- ✔ **Before each use**, check the removal and mounting aid **carefully** for damage, loose parts, or unauthorised modifications. **Never** use it if you notice any such deficiencies!
- ✔ Use **only** genuine **GEDORE Automotive** spare parts and accessories!
- ✔ **Before using** the removal and mounting aid, make sure that **no** unauthorised persons are in the immediate environment!
- ✔ **Always** observe the **max. loading capacity** when using the removal and mounting aid, and **never** exceed it!
- ✔ **Never** stand in axial extension of the removal and mounting aid when it is under load!
- ✔ **Always** keep hair, clothing, and gloves away from rotating parts!

- ✔ **Never** use the removal and mounting aid with an unauthorised drive. Operate it **only** with an approved drive!
- ✔ **Always** wear your personal protective equipment (*safety goggles, protective gloves, safety shoes*) during work!
- ✔ Interrupt your work **immediately** if you are unsure about using the removal and mounting aid, and contact **GEDORE Automotive GmbH if necessary!**
- ✔ For safety reasons, ensure that a damaged removal and mounting aid is no longer used! Professional inspection and repair may only be carried out by specially trained personnel at **GEDORE Automotive GmbH!**
- ✔ **Always** use the removal and mounting aid as intended. Non-compliance will invalidate any warranty claim and may significantly reduce its durability!

1.9 Work environment

For your safety, **only** use the removal and mounting aid in a safe working environment.

- ✔ The workplace **must** be clean and tidy.
- ✔ The workplace **must** be sufficiently large and illuminated.
- ✔ The workplace **must** be on a solid and non-skidding floor.
- ✔ The workplace **must** be safeguarded against access of unauthorised persons.
- ✔ The workplace **must** have a room temperature between -10°C and +40°C.

1.10 Emissions

Molybdenum disulphide paste can drip when using the removal and mounting aid and thus pose a hazard to the environment.

- ✔ **Immediately** remove excess molybdenum disulphide paste, for example with the help of a cleaning rag.
- ✔ In case of skin contact with hydraulic oil, clean the affected area **immediately** with degreasing soap and water.
- ✔ **Be sure to** dispose of pollutants such as molybdenum disulphide paste in an environmentally friendly manner.
- ✔ Safety data sheets *in accordance with Regulation (EC) No. 1907/2006*, for molybdenum disulphide paste (**MOLYKOTE® G-N PLUS PASTE**) can be found on the manufacturer's site on the Internet (**World Wide Web**) or, if required, contact **GEDORE Automotive GmbH**.

1.11 Maintenance

Perform maintenance on the removal and mounting aid **at regular intervals** and **only** when the tool is not tensioned or compressed! Poor and improper maintenance can damage the removal and mounting aid, thus causing **DEATH** or **SEVERE INJURIES!**

Prior to each use:

- ✔ **Prior to each use**, check the removal and mounting aid **carefully** for damage, loose parts or unauthorised modifications!
- ✔ **Prior to each use** of the removal and mounting aid, check the spindles for contamination and damage. If necessary, clean them, and subsequently lubricate them **only** with molybdenum disulphide paste! (For example, **GEDORE Automotive - KL-0014-0030**)

Every 6 months:

- ✔ Clean and lubricate the spindles on the removal and mounting aid **at least every 6 months** and **only** with molybdenum disulphide paste! (For example, **GEDORE Automotive - KL-0014-0030**)

Recommended: Every 24 months:

- ✔ Have the removal and mounting aid professionally checked **every 24 months** by authorised **GEDORE Automotive GmbH** specialists!

1.12 Troubleshooting

Only perform troubleshooting on the removal and mounting aid when it is tension-free!

Problem: The spindle clamping nuts of the removal and mounting aid are sluggish.

Reason: Spindles soiled or insufficiently lubricated; wrong lubricant used.

Remedy: Clean the spindles, check them for damage, and lubricate **exclusively** with molybdenum disulphide paste. (For example, **GEDORE Automotive - KL-0014-0030**)

2. PRODUCT DESCRIPTION

2.1 KL-0029-200 (E/K) - Removal and mounting aid for McPherson suspension struts

In **combination** with the vehicle-specific supplementary kits, the removal and mounting aid permits a McPherson strut to be removed and installed quickly and, **above all, in a time-saving way.**

By preloading the McPherson strut directly on the vehicle, there is no need to loosen the drive shaft and axle guide, and the joints of the guide rod and track rod. There is no need either for a wheel alignment as it is required by the manufacturer.

In combination with the vehicle-specific supplementary kits, the special design offers a universal field of application. The shape of the spring is not relevant here.

The considerable time saving of up to 50% makes the removal and mounting aid a worthwhile investment for the future.

EN

Necessary accessories: Vehicle-specific supplementary kits - **KL-0029-1..series (see chapter 2.4)**

ⓘ Never use the removal and mounting aid to disassemble a suspension strut.

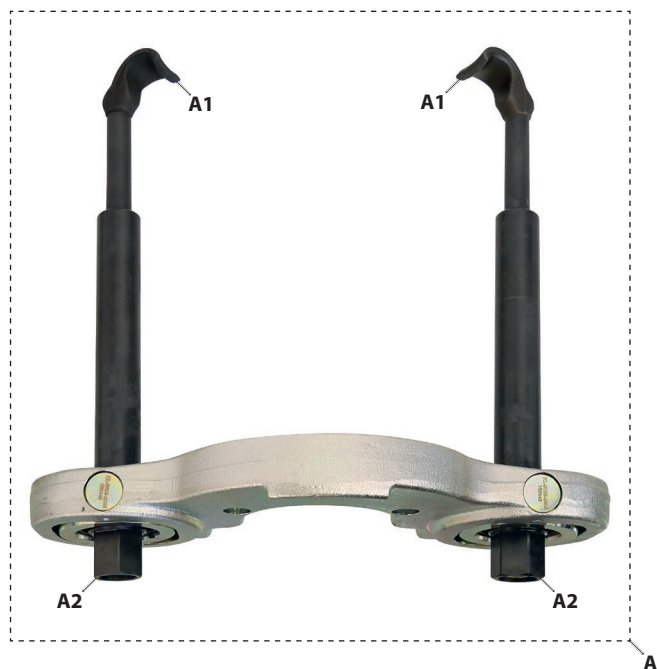

The required vehicle-specific supplementary kits can be found in **Chapter 2.4**

2.2 Scope of delivery

Item	Description	Qty.
A	Removal and mounting aid for McPherson suspension struts, without screws	1
A1	Hook	2
A2	Clamping nut	2
B	Fixing screws for support plate	2

ⓘ KL-0029-200 E is in additional foam insert - KL-0029-1090-1 A
 KL-0029-200 K is in additional plastic case - KL-0029-2090

2.3 Specifications

- Max. load: 17 500N
- Drive of the clamping nut: 27mm
- Span (min/max): 250 - 410mm
- Span (min/max): 160mm

KL-0029-111 - Support plate with bolt, VW Audi, size 1

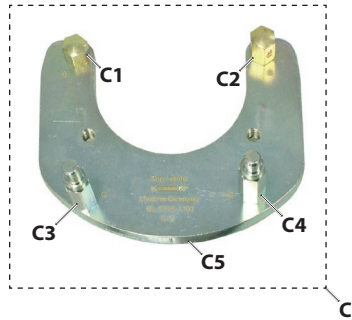

KL-0029-120 A - Supplementary kit VW Audi, size 2

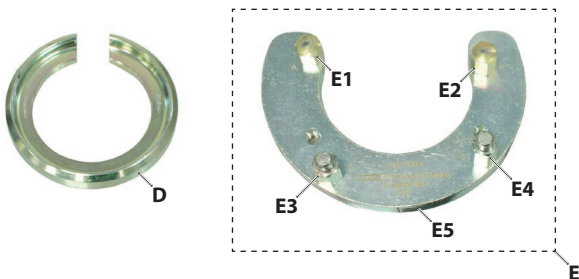

2.4 Supplementary kits for the removal and mounting aid

In combination with the vehicle-specific supplementary kits, the removal and mounting aid is suitable for the vehicles listed below.

KL-0029-110 A - Supplementary kit VW-Audi size 1, Size 2, size 3

Consists of KL-0029-111 + KL-0029-120 A + KL-0029-130 A.

KL-0029-111- Support plate with pin VW-Audi size 1

Fits VW-Audi vehicles on MQB platform such as, for example, VW Golf VII (5G); Audi A3 (8V), etc.

Item	Part no.	Description	Qty.
C	KL-0029-111	Support plate size 1 with bolt	1
C1	KL-0029-1102	Bolt 12.5mm long	1
C2	KL-0029-1103	Bolt 19.5mm long	1
C3	KL-0029-1104	Bolt with pin 33.5mm long	1
C4	KL-0029-1105	Bolt with pin 37mm long	1
C5	KL-0029-1101	Support plate size 1	1

KL-0029-120 A - Supplementary kit VW-Audi size 2

Fits VW-Audi, Seat, Škoda vehicles on PQ35 platform such as VW Caddy III (2K), EOS (1F7), Golf V (1K, 6R), Golf VI (5K), Golf Plus (5M), Jetta III (1K2), Passat (3C, 363, 365), Scirocco (137), Touran (1T), Tiguan (5N); Audi A3 (8P), TT (8J), Q3 (8U); Seat Altea (5P1), Altea XL (5P1), Leon II (1P1), Toledo III (5P2); Škoda Octavia (1Z3), Octavia (1Z5), Superb (3T4), etc.

Item	Part no.	Description	Qty.
D	KL-0029-1209 A	Support ring size 2 open	1
E	KL-0029-121	Support plate size 2 with bolt	1
E1	KL-0029-1102	Bolt 12.5mm long	1
E2	KL-0029-1103	Bolt 19.5mm long	1
E3	KL-0029-1202	Bolt with pin 18.1mm long	1
E4	KL-0029-1203	Bolt with pin 21.3mm long	1
E5	KL-0029-1201	Support plate size 2	1

KL-0029-122 - Supplement KYB for KL-0029-120 A, VW Audi

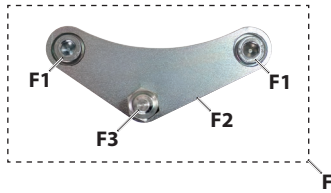

Screw the supplement [F] onto the support plate [E5]* as shown.

* Included in the supplementary kit **KL-0029-120 A**.

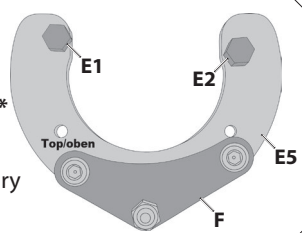

KL-0029-122 - Supplement KYB for KL-0029-120 A, VW-Audi

Fits VW-Audi, Seat, and Škoda vehicles on PQ35 platform, **with aftermarket struts by KYB (KAYABA)** (e.g. KYB 334834). Installed, for example on VW Golf V (1K), Golf VI (5K, AJ), Golf Plus (5M), Jetta V (1K), Jetta VI (5K, AJ), Beetle (5C), Caddy III (2K, 2C); Audi A3 (8P); Seat Altea (5P), Altea XL (5P), Leon (1P), Toledo III (5P); Škoda Octavia II (1Z), Yeti (5L).

Item	Part no.	Description	Qty.
F	KL-0029-122	Supplement KYB for KL-0029-120 A, VW Audi	1
F1	KL-1615-1128	Cap screw M8 x 16 mm	2
F2	KL-0029-1221	Support sheet for support plate size 2	1
F3	KL-0029-1222	Bolt with pin 20mm	1

i Necessary supplementary kit:

KL-0029-120 A - Supplementary kit VW Audi size 2

KL-0029-130 A - Supplementary kit VW Audi, size 3

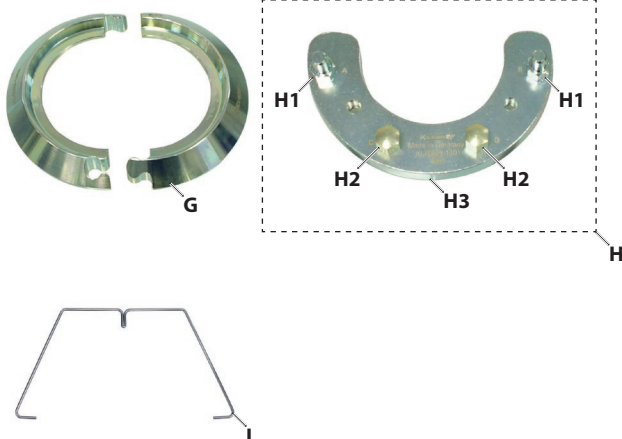

KL-0029-130 A - Supplementary kit VW-Audi, size 3

Fits VW-Audi, Seat, Škoda vehicles on PQ25 or NSF platform, such as VW Polo (6R), Up! (12); Audi A1 (8X); Seat Ibiza V (6J5), Ibiza V ST (6J8), Mii (KF1); Škoda Rapid, Citigo, etc.

Item	Part no.	Description	Qty.
G	KL-0029-1309	Support ring pair size 3	1
H	KL-0029-131	Support plate size 3 with bolt	1
H1	KL-0029-1302	Bolt with pin 8.5mm long	2
H2	KL-0029-1102	Bolt 12.5mm long	2
H3	KL-0029-1301	Support plate size 3	1
I	KL-0029-1303	Shock absorber hold-down unit	1

i The shock absorber hold-down unit [I] facilitates the removal of the suspension strut and ensures that the piston rod is held in the upper spring collar during preloading and also pressed down.

KL-0029-150 - Supplementary kit Ford, size 5

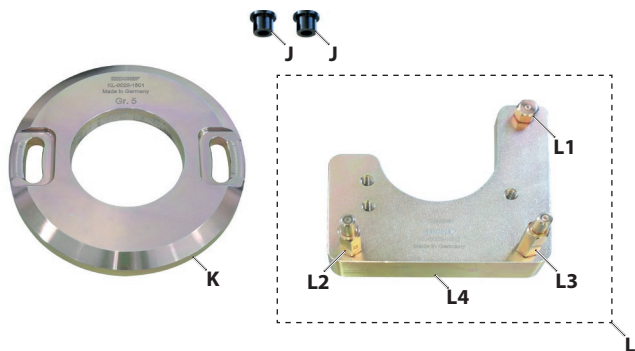

KL-0029-150 - Supplementary kit Ford, size 5

Suitable for Ford front axle suspension struts. Installed in, for example, Ford Mondeo IV (BA7), S-Max (WA6), and Galaxy (WA6).

Item	Part no.	Description	Qty.
J	KL-0029-1002-1	Extension sleeve	2
K	KL-0029-1501	Support ring size 5	1
L	KL-0029-151	Support plate size 5 with bolt	1
L1	KL-0029-1503	Bolt 8 mm	1
L2	KL-0029-1504	Bolt with pin 22mm	1
L3	KL-0029-1505	Bolt with pin 26mm	1
L4	KL-0029-1502	Support plate size 5	1

Important note:

With the extension sleeves [J] the old spring preloading tool (basic unit) - **KL-0029-100** **must be** upgraded.

This provides an opening width extended by **approximately 11mm**, which is absolutely necessary when using the supplementary kit **KL-0029-150**. (see below)

KL-0029-152

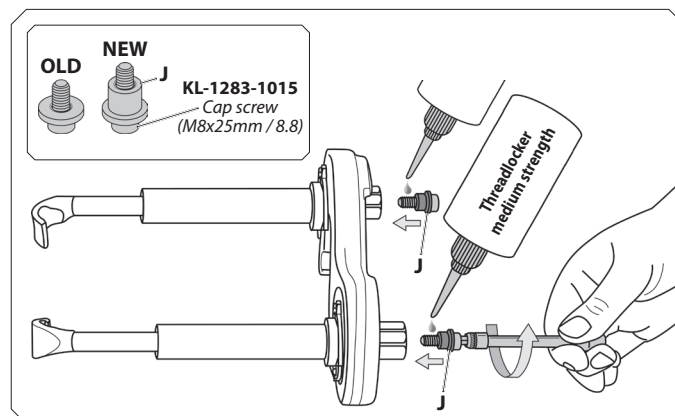
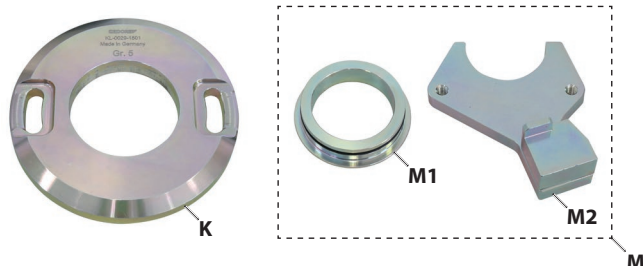

Insert the adapter ring [M1] into the support ring [K] from behind as shown.

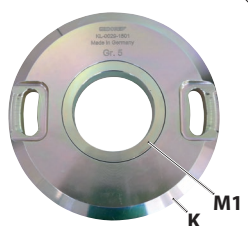

KL-0029-152- Supplementary kit Ford, size 8

Fits Ford front axle suspension struts, for example, Ford Kuga I and Kuga II (DM2).

Item	Part no.	Description	Qty.
K	KL-0029-1501	Support ring size 5	1
M	KL-0029-1520	Supplementary kit Ford, size 8, small	1
M1	KL-0029-1521	Adapter ring with O-ring	1
M2	KL-0029-1522	Support plate size 8 with support	1

KL-0029-160 A - Supplementary kit BMW, size 6

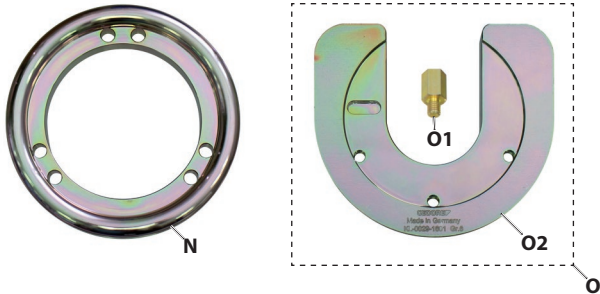

KL-0029-160 A - Supplementary kit BMW, size 6
Suitable for BMW front axle suspension struts. Installed in, for example, BMW Series 3 (E46), (E90 / E91); Series 5 (E39), (E60 / E61); Series 1 (E81 / E87).

Item	Part no.	Description	Qty.
N	KL-0029-1602 A	Support ring size 6	1
O	KL-0029-161	Support plate size 6 with bolt	1
O1	KL-0029-1103	Bolt 19.5mm long, BMW 5 Series (E39)	1
O2	KL-0029-1601	Support plate size 6	1



For the **BMW Series 5 (E39)**, mount the additional bolt [O1] on the support plate [O2].

This is not required for all other vehicles.

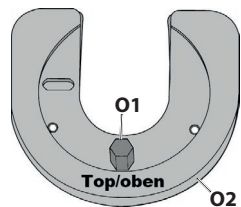

KL-0029-170 - Supplementary kit VW T5, size 7

Fits VW front axle suspension struts. Installed in, for example, VW T5 (7J, 7H, 7E, 7F).

Item	Part no.	Description	Qty.
P	KL-0029-1702	Support ring size 7	1
Q	KL-0029-171	Support plate size 7 with bolt	1
Q1	KL-0029-1703	Bolt with pin 10mm	1
Q2	KL-0029-1701	Support plate size 7	1

KL-0029-170 - Supplementary kit VW T5, size 7

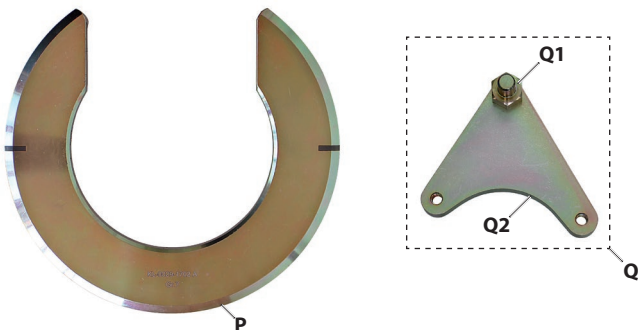

3. PREPARATION

⚠ WARNING

Misuse and/or **overload** can cause the removal and mounting aid to slip, break, and thus drop or fling around. This can cause **DEATH** or **SEVERE INJURIES!**

► **Prior to using** the removal and mounting aid, read and understand **all** safety instructions and warnings listed in **Chapter 1**, and **always observe** them for safe use!

► Use the removal and mounting aid **as intended**, and **always** carry out maintenance and repairs in compliance with the regulations on occupational safety and accident prevention as well as the vehicle manufacturer's instructions!

► **Before each use**, check the removal and mounting aid **carefully** for damage, loose parts, or unauthorised modifications. **Never** use it if you notice any such deficiencies!

► **Always** wear your personal protective equipment (for example *safety goggles, protective gloves, safety shoes*) when working!

📷 1: Select the suitable supplementary kit and install the support plate on the basic tool.

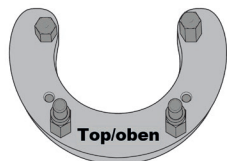
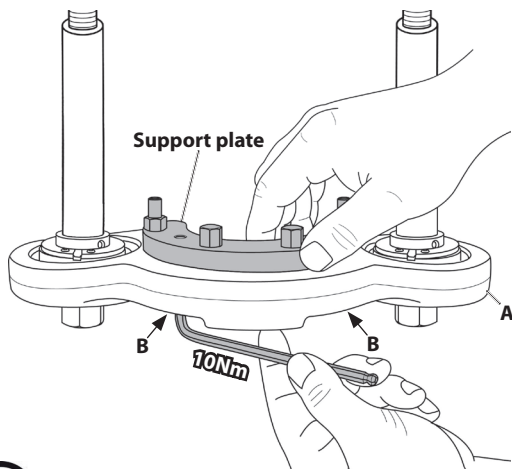

Check the assembly of the **support plate** by consulting **chapter 2.4**.

📷 2: Secure wheel bearing housing.

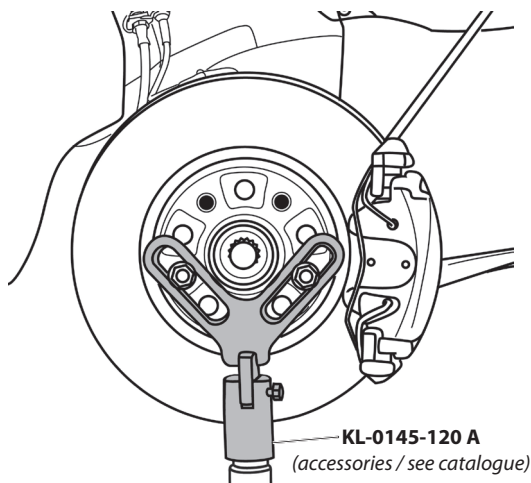

📷 3: Expand the suspension strut clamping bore.

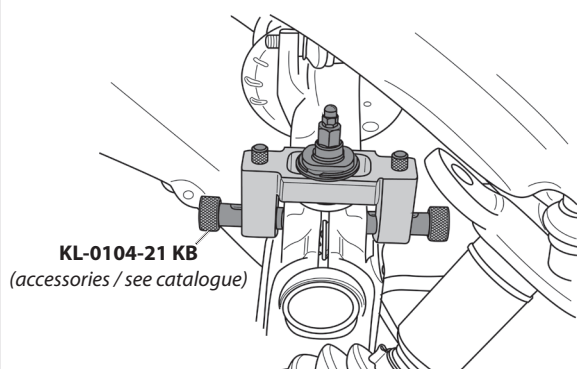

3.1 Checking the scope of delivery

Prior to preparing or using the removal and mounting aid, check that all parts of the scope of delivery are available (see **chapter 2.**), and follow the instructions below.

3.2 Preparing the removal and mounting aid

1. Depending on the vehicle, select the appropriate supplementary kit in **Chapter 2.4**, and prepare it.

⚠ WARNING

The **support plate** can slip off, and thus the removal and mounting aid can fall down and fling around. This can cause **DEATH** or **SEVERE INJURIES**.

➤ Before use, **always** check the mounting of the **support plate** by consulting **Chapter 2.4!**

➤ Always mount the **support plate** with the mark "Top/oben" pointing upwards to the basic unit [A]!

2. Then attach the **support plate** as shown in **📷 1**, in the correct position to the basic unit [A] using the fixing screws [B].

ⓘ Fasten the socket head fixing screws [B] clockwise with **10Nm**.

3.3 Preparing the vehicle

CAUTION

There is a risk of damaging the brake hoses, cable connections, and drive shafts.

➤ **Always** observe the vehicle-specific application procedures in the repair guide by the vehicle manufacturer!

➤ **Never** subject sensitive vehicle components to tension or pressure while working with the removal and mounting aid.

1. Lift the vehicle safely according to the manufacturer's instructions and loosen or prepare all necessary parts.

For example:

Take off the wheels and support the wheel bearing housing **📷 2**, for example, by using the support device - **KL-0145-120 A** (accessories / see catalogue), and a gearbox jack (accessories).

Loosen the strut from the spring dome, and lower it slightly above the gearbox jack.

Widen the suspension strut clamping hole **📷 3**, for example by means of the expanding tool - **KL-0104-21 KB** (accessories / see catalogue).

📷 4: Apply the removal and mounting aid (basic unit) to the suspension strut...

...in combination with KL-0029-111
VW Audi / MQB platform

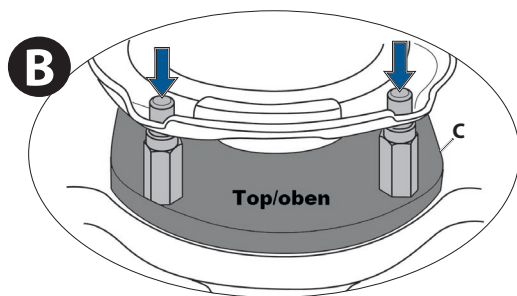
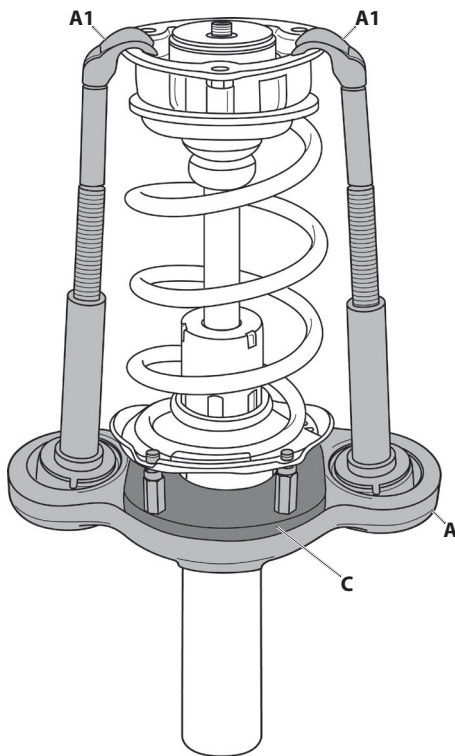
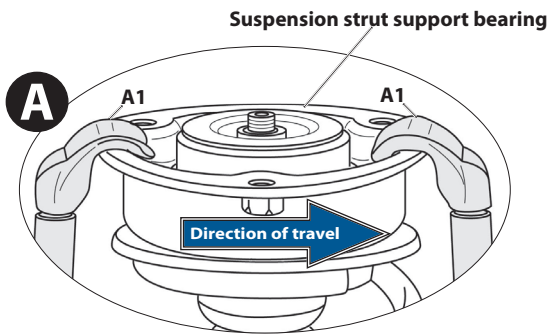

4. TYPICAL APPLICATION

This typical application describes the compression of a McPherson strut for the removal and installation on the front axle.

4.1 Placing the basic tool to the suspension strut...

Depending on the vehicle, the removal and mounting aid (basic unit) is attached to the suspension strut together with the vehicle-specific supplementary kit.

Applying the removal and mounting aid (basic unit) to the spring strut...

- ...in combination with **KL-0029-111** / see **Chapter 4.1.1**
- ...in combination with **KL-0029-120 A** / see **Chapter 4.1.2**
- ...in combination with **KL-0029-122** / see **Chapter 4.1.3**
- ...in combination with **KL-0029-130 A** / see **Chapter 4.1.4**
- ...in combination with **KL-0029-150** / see **Chapter 4.1.5**
- ...in combination with **KL-0029-152** / see **Chapter 4.1.6**
- ...in combination with **KL-0029-160 A** / see **Chapter 4.1.7**
- ...in combination with **KL-0029-170** / see **Chapter 4.1.8**

4.1.1 ...in combination with KL-0029-111

⚠ WARNING

The hooks [A1] and the support plate [C] can slip off the suspension strut. As a consequence, the removal and mounting aid can fall down and fling around. This can cause **DEATH** or **SEVERE INJURIES**.

- ✔ **Be careful** to remove dirt and loose rust from the suspension strut support bearing.
- ✔ Make sure that the hooks [A1] on the top of the suspension strut support bearing are fully and securely engaged **📷 4A**
- ✔ Make sure that the bolts of the support plate [C] engage completely and safely in the holes of the lower spring plate **📷 4B**.

1. Apply the prepared removal and mounting aid in the correct position as shown in **📷 4**.
2. Proceed to:
 - **Chapter 4.2 / Strut removal.**
 - **Chapter 4.3 / Strut installation.**

5: Apply the removal and mounting aid (basic unit) to the spring strut...

...in combination with KL-0029-120 A

VW Audi, Seat, Škoda / PQ35 platform

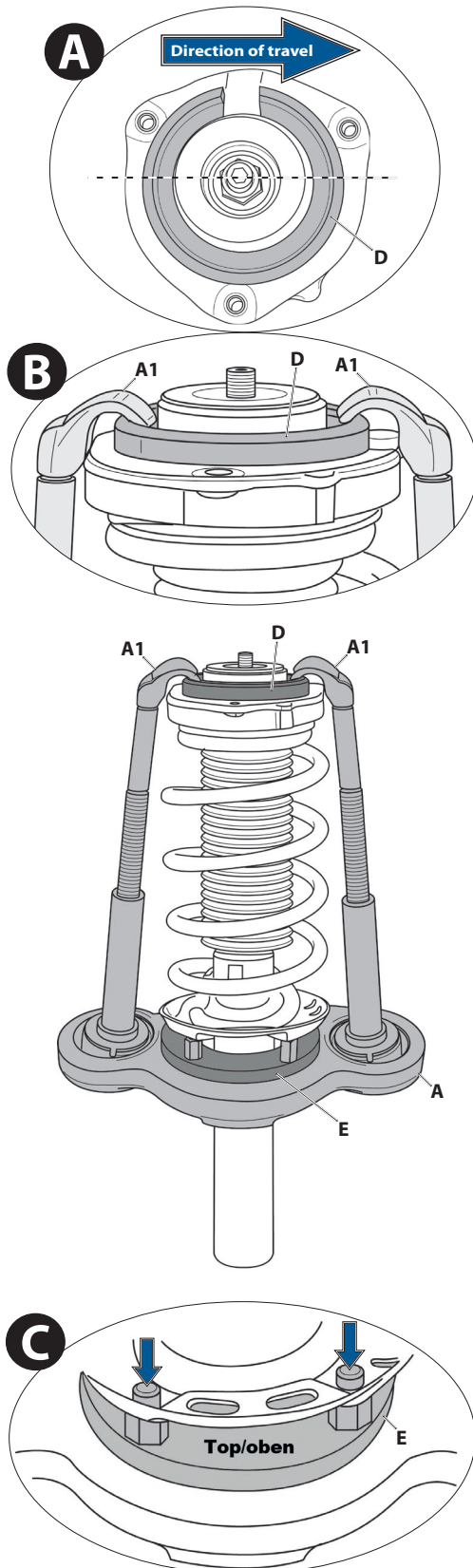

4.1.2 ...in combination with KL-0029-120 A

!WARNING

The support ring [D] can slip off the suspension strut support bearing. As a consequence, the removal and mounting aid can fall down and fling around. This can cause **DEATH** or **SEVERE INJURIES**.

➤ **Be careful** to remove dirt and loose rust from the suspension strut support bearing.

➤ Place the support ring [D] evenly and securely on the spring-strut support bearing!

1. Place the support ring [D], as shown in **5A+B**, in the correct position with the opening facing the suspension strut support bearing.

EN

!WARNING

The hooks [A1] and the support plate [E] can slip off the support ring [D] or the suspension strut. As a consequence, the removal and mounting aid can fall down and fling around. This can cause **DEATH** or **SEVERE INJURIES**.

➤ Ensure that the hooks [A1] on top of the support ring [D] engage fully and safely **5B**

➤ Ensure that the bolts of the support plate [E] engage completely and safely in the holes of the lower spring plate **5C**.

2. Apply the prepared removal and mounting aid in the correct position as shown in **5**.

3. Proceed to:

- **Chapter 4.2 / Strut removal.**
- **Chapter 4.3 / Strut installation.**

6: Apply the removal and mounting aid (basic unit) to the spring strut...

**...in combination with KL-0029-122
+ (supplementary kit KL-0029-120 A)**

**VW Audi, Seat, Škoda / PQ35 platform
with aftermarket suspension struts from KYB (KAYABA)**

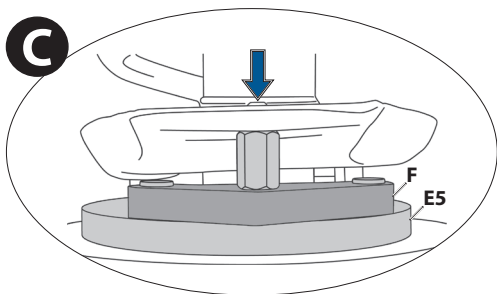
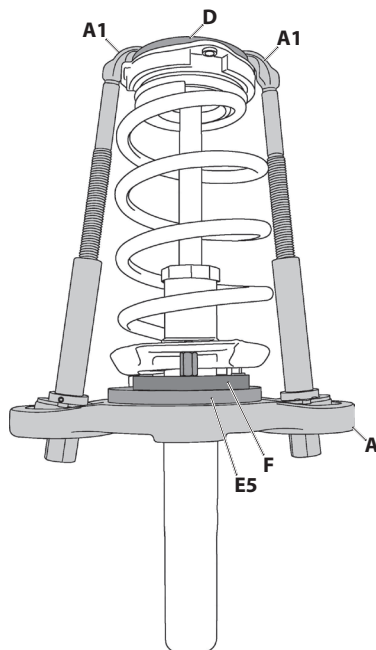
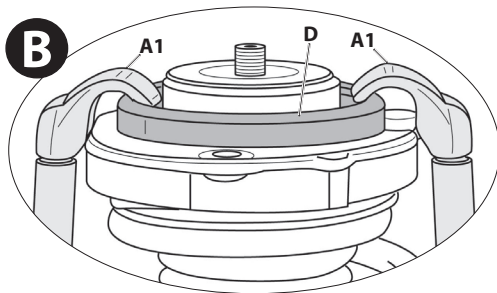
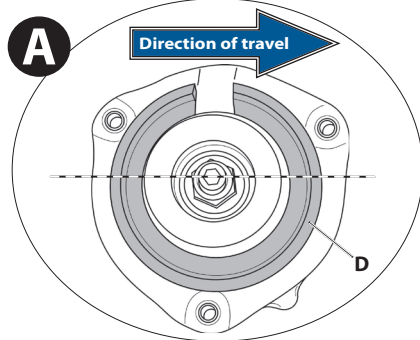

4.1.3 ...in combination with KL-0029-122

Note:

The **supplementary kit VW Audi, size 2 - KL-0029-120 A** is required when you use the **supplement KYB - KL-0029-122!**

!WARNING

The support ring [D] can slip off the suspension strut support bearing. As a consequence, the removal and mounting aid can fall down and fling around. This can cause **DEATH** or **SEVERE INJURIES**.

► **Be careful** to remove dirt and loose rust from the suspension strut support bearing.

► Place the support ring [D] evenly and securely on the spring-strut support bearing!

1. Place the support ring [D], as shown in **6A+B**, in the correct position with the opening facing the suspension strut support bearing.

!WARNING

The hooks [A1] and the support plate [E5] with supplement [F] can slip off the support ring [D] or the suspension strut. As a consequence, the removal and mounting aid can fall down and fling around. This can cause **DEATH** or **SEVERE INJURIES**.

► Ensure that the hooks [A1] on top of the support ring [D] engage fully and safely **6B**

► Ensure that the bolts of the support plate [E5] with supplement [F] fully and safely engage in the holes of the lower spring plate **6C**.

2. Apply the prepared removal and mounting aid in the correct position as shown in **6**.

3. Proceed to:

- **Chapter 4.2 / Strut removal.**
- **Chapter 4.3 / Strut installation.**

EN

🔧7: Apply the removal and mounting aid (basic unit) to the spring strut...

...in combination with KL-0029-130 A
VW Audi, Seat, Škoda / PQ25 + NSF platform

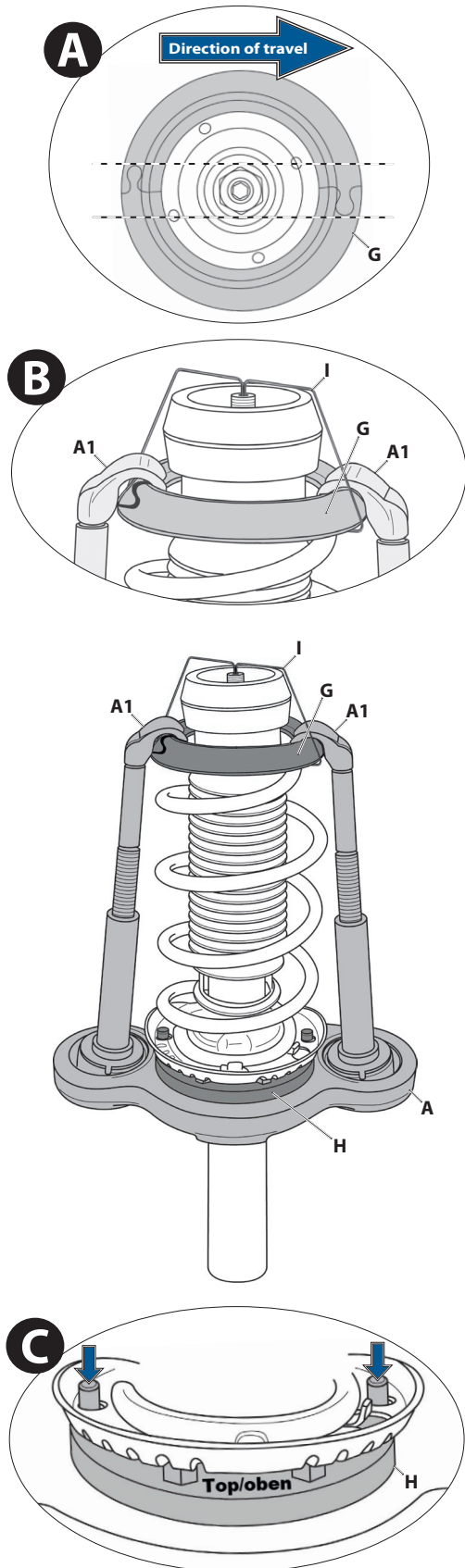

4.1.4 ...in combination with KL-0029-130 A

⚠️WARNING

The pair of bearing rings [G] can slip off the suspension strut support bearing. As a consequence, the removal and mounting aid can fall down and fling around. This can cause **DEATH** or **SEVERE INJURIES**.

➤ **Be careful** to remove dirt and loose rust from the suspension strut support bearing.

➤ Place the support ring pair [G] evenly and securely on the suspension strut support bearing!

1. Mount the support ring pair [G] as shown in **🔧7A+B**, onto the suspension strut support bearing in the correct position and pointing towards the direction of travel.

Mount the shock absorber hold-down unit [I] as shown in **🔧7B**.

① The shock absorber hold-down unit [I] facilitates the removal of the suspension strut and ensures that the piston rod remains in the upper spring collar during compressing, and is also pressed down.

⚠️WARNING

The hooks [A1] and the support plate [H] can slip off the support pair [G] or the suspension strut. Thus, the removal and mounting aid can fall down and fling around. This can cause **DEATH** or **SEVERE INJURIES**.

➤ Ensure that the hooks [A1] on top of the support ring pair [G] engage fully and safely **🔧7B**

➤ Ensure that the bolts of the support plate [E] engage completely and safely in the holes of the lower spring plate **🔧7C**.

2. Apply the prepared removal and mounting aid in the correct position as shown in **🔧7**.

3. Proceed to:

- **Chapter 4.2 / Strut removal.**
- **Chapter 4.3 / Strut installation.**

8: Apply the removal and mounting aid (basic unit) to the spring strut...

...in combination with KL-0029-150

Ford

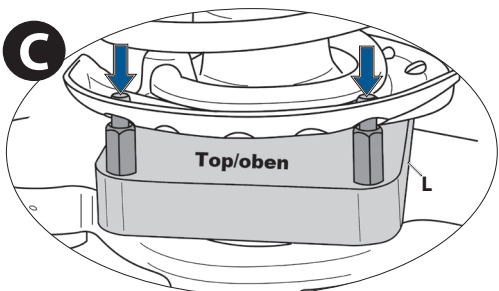
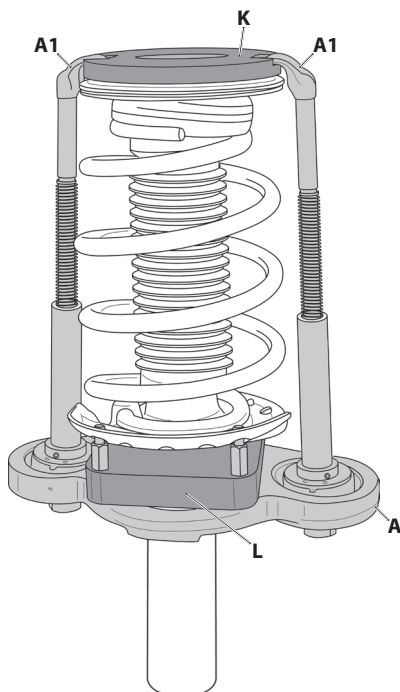
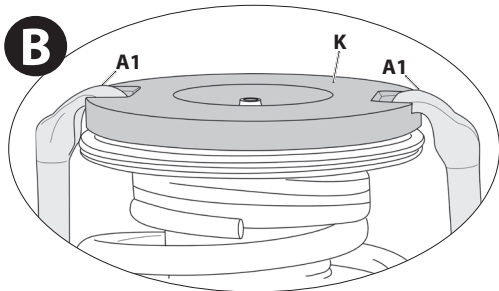
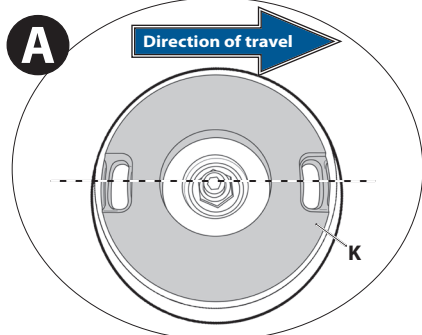

4.1.5 ...in combination with KL-0029-150

⚠ WARNING

The support ring [K] can slip off the suspension strut support bearing. As a consequence, the removal and mounting aid can fall down and fling around. This can cause **DEATH** or **SEVERE INJURIES**.

► **Be careful** to remove dirt and loose rust from the suspension strut support bearing.

► Place the support ring [K] evenly and securely on the suspension strut support bearing!

1. Place the support ring [K] as shown in **8A+B** correctly onto the suspension strut support bearing. It must point towards the direction of travel.

⚠ WARNING

The hooks [A1] and the support plate [L] can slip off the support ring [K] or the suspension strut. As a consequence, the removal and mounting aid can fall down and fling around. This can cause **DEATH** or **SEVERE INJURIES**.

► Ensure that the hooks [A1] on top of the support ring [K] engage fully and safely **8B**

► Ensure that the bolts of the support plate [L] engage completely and safely in the holes of the lower spring plate **8C**.

2. Apply the prepared removal and mounting aid in the correct position as shown in **8**.

3. Proceed to:

- **Chapter 4.2 / Strut removal.**
- **Chapter 4.3 / Strut installation.**

📷9: Apply the removal and mounting aid (basic unit) to the spring strut...

...in combination with KL-0029-152

Ford

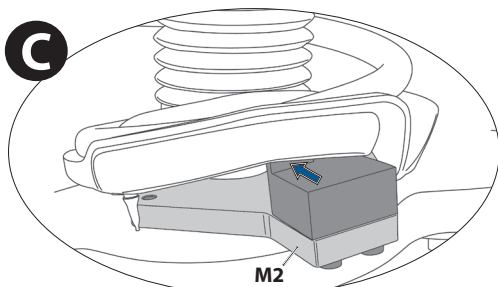
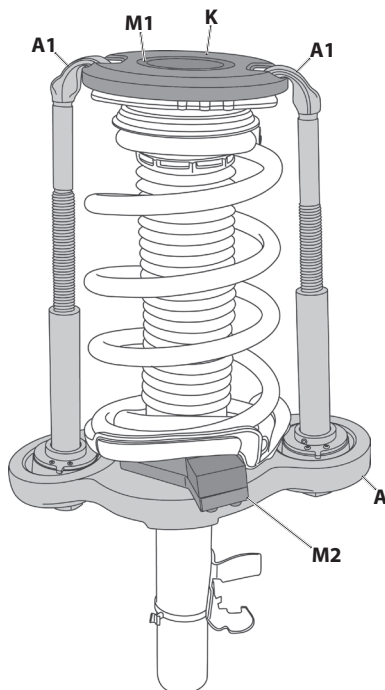
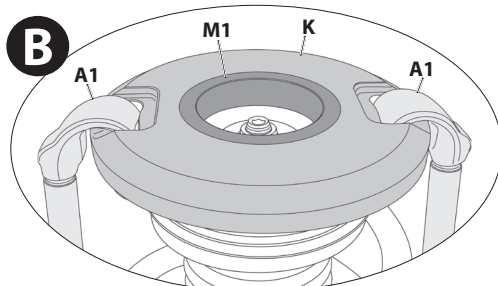
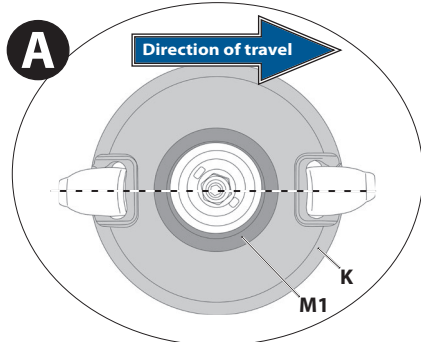

4.1.6 ...in combination with KL-0029-152

⚠️WARNING

The support ring [K] with adapter ring [M1] can slip off the strut support bearing. As a consequence, the removal and mounting aid can fall down and fling around. This can cause **DEATH** or **SEVERE INJURIES**.

➤ **Be careful** to remove dirt and loose rust from the suspension strut support bearing.

➤ Place the support ring [K] with adapter ring [M1] evenly and securely on the strut support bearing!

1. Place the support ring [K] with adapter ring [M1] as shown in **📷9A+B**, correctly on the suspension strut support bearing. It must point towards the direction of travel.

EN

⚠️WARNING

The hooks [A1] and the support plate [M2] can slip off the support ring [K] with adapter ring [M1] or the suspension strut. As a consequence, the removal and mounting aid can fall down and fling around. This can cause **DEATH** or **SEVERE INJURIES**.

➤ Ensure that the hooks [A1] on top of the support ring [K] with adapter ring [M1] fully and safely engage **📷9B**

➤ Ensure that the support plate [M2] rests fully and safely of the lower spring plate **📷9C**.

2. Apply the prepared removal and mounting aid in the correct position as shown in **📷8**.

3. Proceed to:

- **Chapter 4.2 / Strut removal.**
- **Chapter 4.3 / Strut installation.**

📷 10: Applying the removal and mounting aid (basic unit) to the spring strut...

...in combination with KL-0029-160 A
BMW

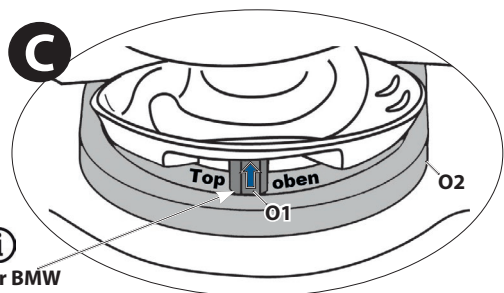
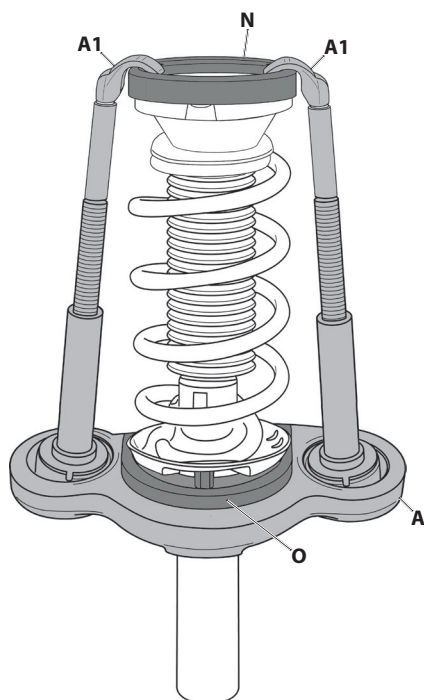
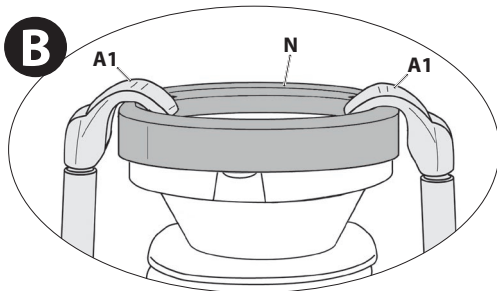
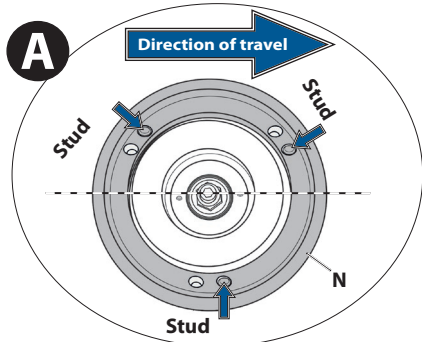

i
Only for BMW
Series 5 (E39)

4.1.7 ...in combination with KL-0029-160 A

⚠️ WARNING

The support ring [N] can slip off the suspension strut support bearing. As a consequence, the removal and mounting aid can fall down and fling around. This can cause **DEATH** or **SEVERE INJURIES**.

- ✔ Be careful to remove dirt and loose rust from the suspension strut support bearing.
- ✔ Place the support ring [N] evenly and securely on the suspension strut support bearing!
- ✔ Make sure that **all** three stud bolts on the suspension strut support bearing engage completely in the bores for the support ring [N].

1. Place the support ring [N] as shown in **📷 10A+B** correctly on the three stud bolts for the suspension strut support bearing.

⚠️ WARNING

The hooks [A1] and the support plate [O] can slip off the support ring [N] or the suspension strut. As a consequence, the removal and mounting aid can fall down and fling around. This can cause **DEATH** or **SEVERE INJURIES**.

- ✔ Ensure that the hooks [A1] on top of the support ring [N] engage fully and safely **📷 10B**
- ✔ Ensure that the bolts of the support plate [O] engage completely and safely in the holes on the lower spring plate **📷 10C**.

CAUTION

There is a risk of damaging the suspension strut.

- ✔ Please note that **only** the **BMW 5 Series (E39)** requires the bolt [O1] on the support plate [O2]; continue without it on all other vehicles.

2. Apply the prepared removal and mounting aid in the correct position as shown in **📷 10**.

3. Proceed to:

- **Chapter 4.2 / Strut removal.**
- **Chapter 4.3 / Strut installation.**

11: Applying the removal and mounting aid (basic unit) to the spring strut...

**...in combination with KL-0029-170
VW T5**

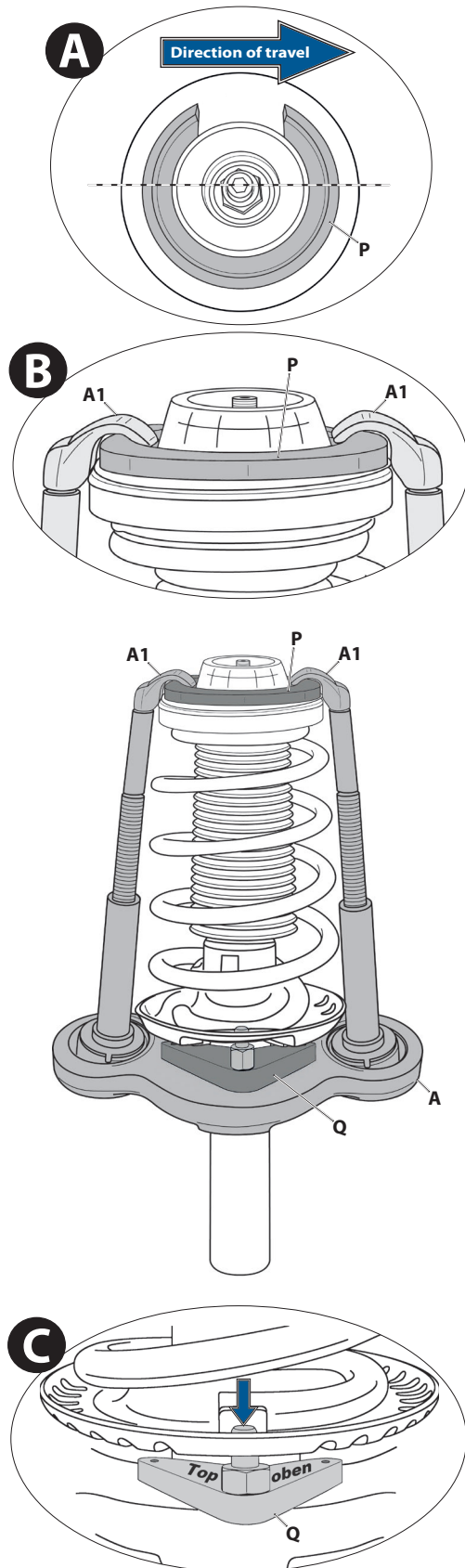

4.1.8 ...in combination with KL-0029-170

⚠ WARNING

The support ring [P] can slip off the suspension strut support bearing. As a consequence, the removal and mounting aid can fall down and fling around. This can cause **DEATH** or **SEVERE INJURIES**.

► **Be careful** to remove dirt and loose rust from the suspension strut support bearing.

► Place the support ring [P] evenly and securely on the suspension strut support bearing!

1. Place the support ring [P], as shown in **11A+B**, in the correct position with the opening facing the suspension strut support bearing.

EN

⚠ WARNING

The hooks [A1] and the support plate [Q] can slip off the support ring [P] or the suspension strut. As a consequence, the removal and mounting aid can fall down and fling around. This can cause **DEATH** or **SEVERE INJURIES**.

► Ensure that the hooks [A1] on top of the support ring [P] engage fully and safely **11B**

► Ensure that the bolt of the support plate [Q] engages completely and safely in the hole on the lower spring plate **11C**.

2. Apply the prepared removal and mounting aid in the correct position as shown in **11**.

3. Proceed to:

- **Chapter 4.2 / Strut removal.**
- **Chapter 4.3 / Strut installation.**

📷 12: Preloading the suspension strut

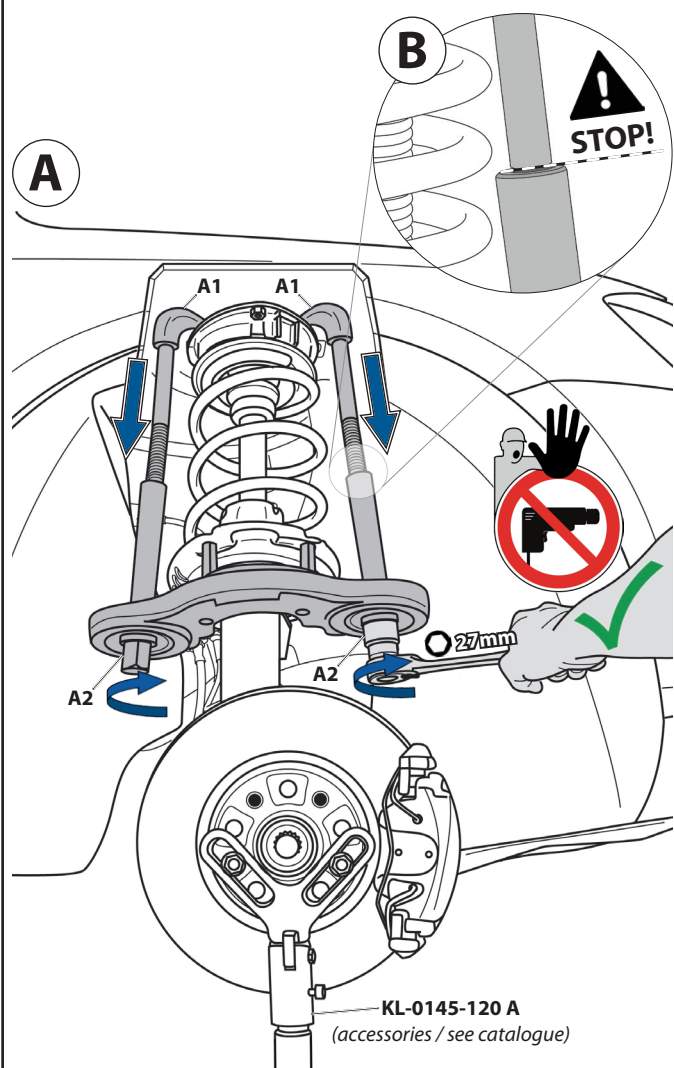

📷 13: Suspension strut preloaded.

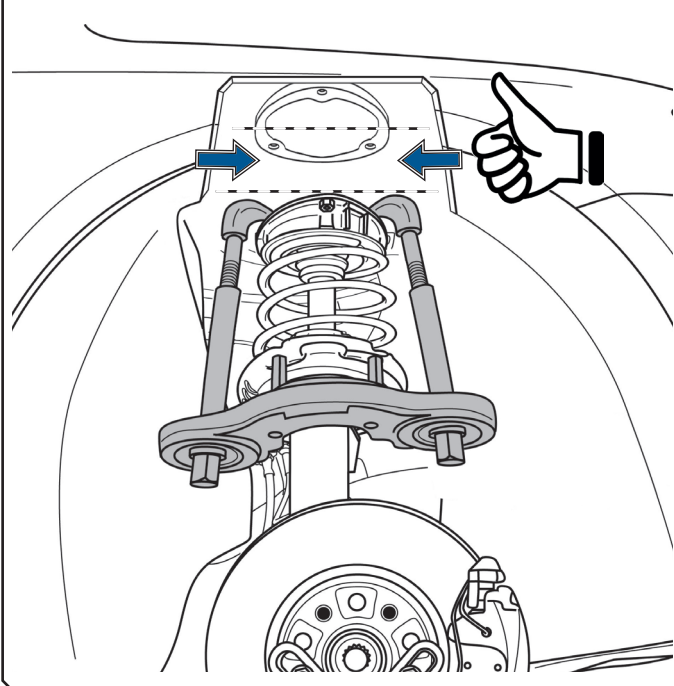

4.2 Suspension strut dismounting

⚠️ WARNING

Very high forces act when preloading suspension struts! There is a risk of breakage or slipping if assembled incorrectly, overloaded, or when the removal and mounting aid is driven by a machine. This can result in **DEATH** or **SEVERE INJURIES** caused by parts being hurled about.

- ✔ Note that the removal and mounting aid may **only** be used to pre-tension MacPherson suspension struts!
- ✔ Do not pre-tension the strut **until all** necessary removal and mounting aid components have been positioned correctly, evenly, and securely on the suspension strut, or have engaged in it!
- ✔ Only use the removal and mounting aid with a manual drive and muscle power, but **never** with a mechanical drive!
- ✔ **Never** exceed the **max. load** of the removal and mounting aid of **17500 Newton!**
- ✔ **Always** turn the drive nuts [A2] alternately and evenly to ensure straight and safe preloading of the suspension strut!
- ✔ Stop compressing at the latest when the threads on the hooks [A1] are no longer visible 📷 12B or before the spring coils are in contact with each other (**Fig. below**)!

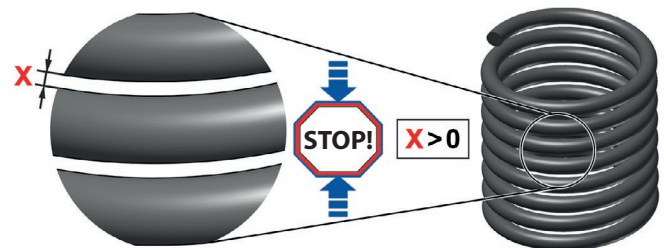

- ✔ Note that when using the support ring pair [G] they may only move slightly against each other during preloading. Otherwise, stop compressing, release the suspension strut, and check and correct the position of the support ring pair [G]. (**See below**)

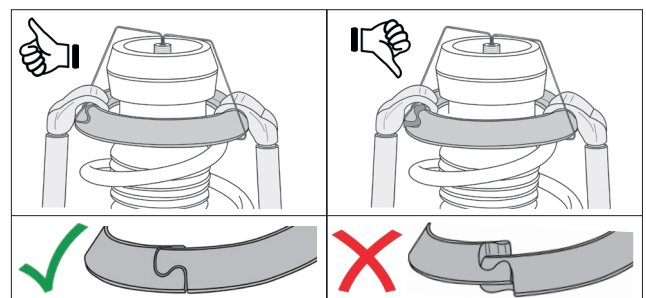

1. Pre-load the suspension strut in a straight line as shown in 📷 12. To do this, turn both drive nuts [A2] (🌀 27mm) alternately and evenly clockwise until the suspension strut has enough space to be removed later from the strut's clamping hole 📷 13.

📷 14: Take the strut out of the vehicle.

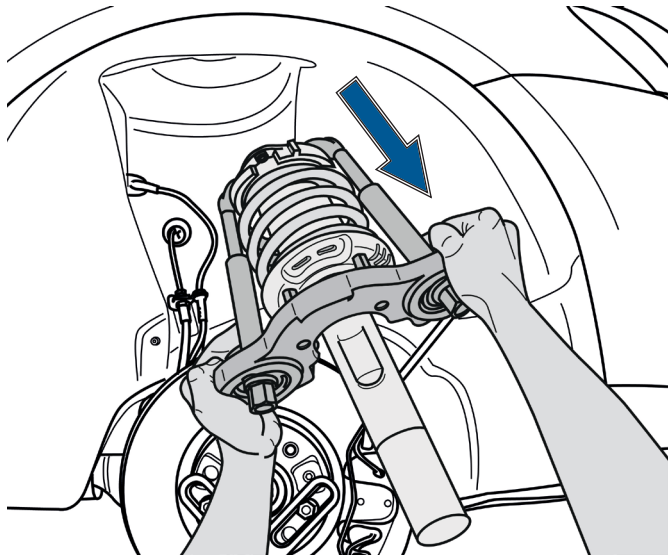

📷 15: Relieve the suspension strut and take the removal and mounting aid away.

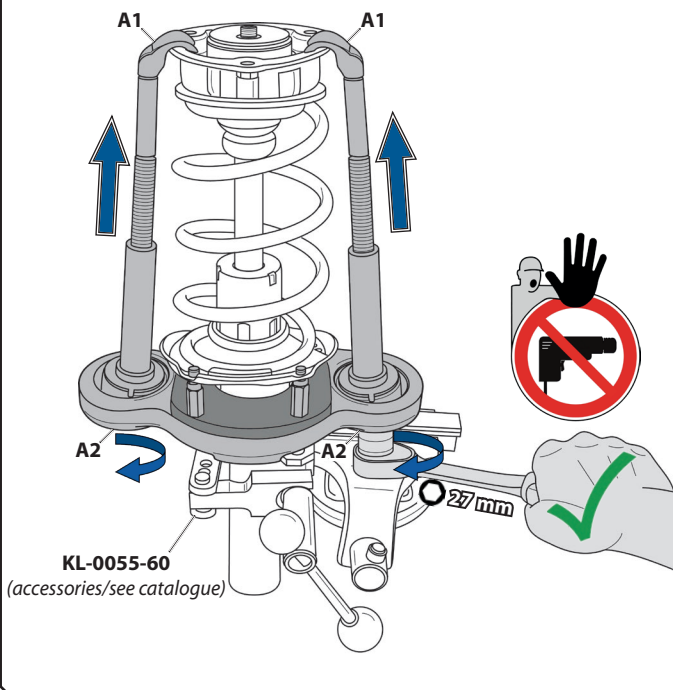
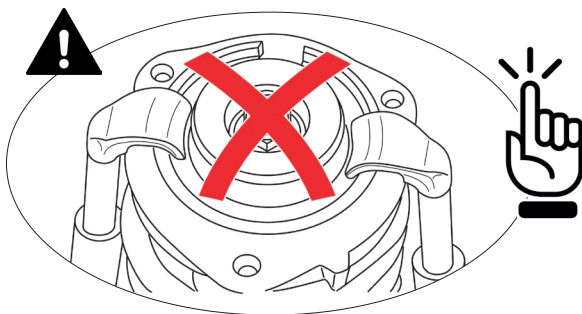

2. Widen the suspension strut clamping hole, for example by means of the expanding tool - **KL-0104-21 KB** (accessories / see catalogue).

Take the suspension strut out of the vehicle's strut clamping hole according to the manufacturer's instructions 📷 14.

⚠️ WARNING

The strut spring and the removal and mounting aid can drop. This can cause **SEVERE INJURIES**.

► **Always** wear your personal protective equipment (*safety goggles, protective gloves, safety shoes*) when working!

CAUTION

The suspension strut can be deformed and damaged.

► **Never** fix the suspension strut in a conventional vice.

3. Clamp the suspension strut in a suitable holding device, for example clamping device - **KL-0055-60** (*accessories / see catalogue*) 📷 15.

⚠️ WARNING

If the removal and mounting aid is misused, there is a risk of breakage or slipping. This can result in **DEATH** or **SERIOUS INJURY** due to the vehicle spring, strut support bearing, and other parts being hurled about!

► **Never** open the piston rod nut on the suspension strut, and **never** dismantle the suspension strut in any way while using the removal and mounting aid!

► Dismantle the suspension strut **only** in combination with a suitable removal and mounting aid, e.g. **KL-0015 / KL-9002 / KL-5501!**

4. Release the suspension strut in a straight line as shown in 📷 15. For this, turn two drive nuts [A2] (⊙ 27mm) alternately and evenly anticlockwise until the hooks [A1] are released.

Subsequently, remove the removal and mounting aid from the suspension strut.

5. Perform further work on the strut according to the manufacturer's instructions.

16: Preloading the suspension strut

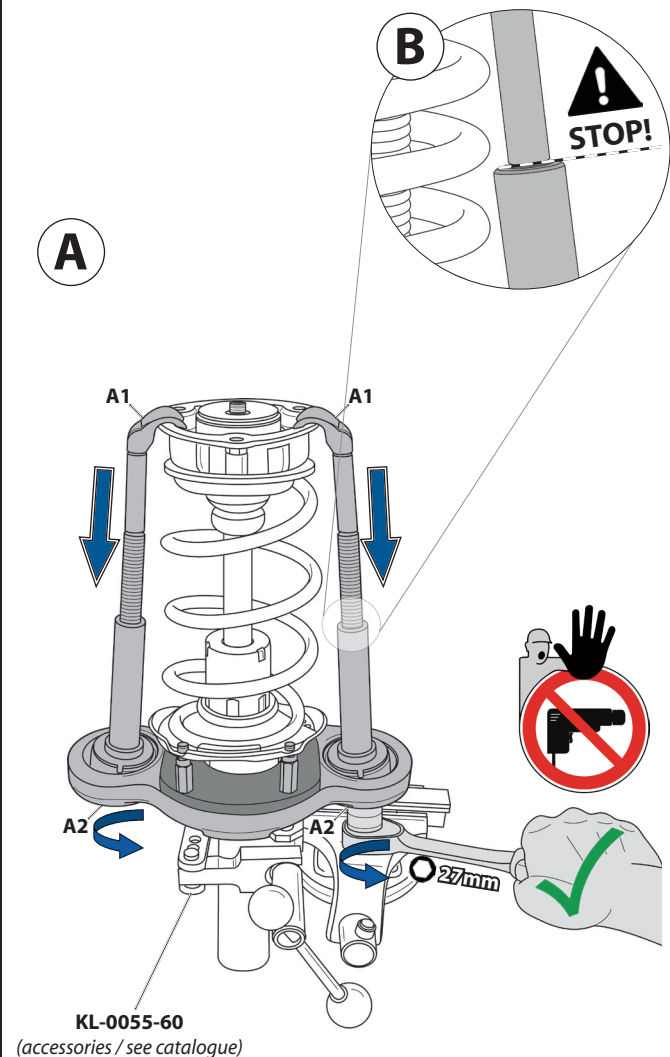

17: Suspension strut preloaded.

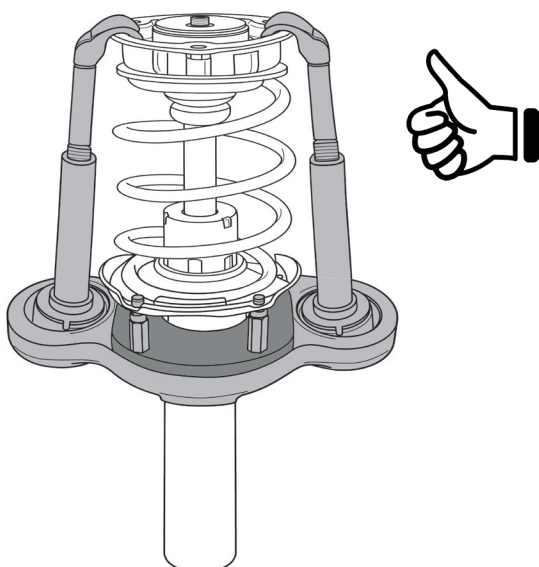

4.3 Suspension strut mounting

1. Depending on the suspension strut, the removal and mounting aid **must** be re-applied as described in chapter 4.1.

⚠ WARNING

Very high forces act when preloading suspension struts! There is a risk of breakage or slipping if assembled incorrectly, overloaded, or when the removal and mounting aid is driven by a machine. This can result in **DEATH** or **SEVERE INJURIES** caused by parts being hurled about.

➤ Note that the removal and mounting aid may **only** be used to pre-tension MacPherson spring struts!

➤ Do not pre-tension the strut **until all** necessary removal and mounting aid components have been positioned correctly, evenly, and securely on the suspension strut, or have engaged in it!

➤ Only use the removal and mounting aid with a manual drive and muscle power, but **never** with a mechanical drive!

➤ **Never** exceed the **max. load** of the removal and mounting aid of **17500 Newton!**

➤ **Always** turn the drive nuts [A2] alternately and evenly to ensure straight and safe preloading of the suspension strut!

➤ Stop compressing at the latest when the threads on the hooks [A1] are no longer visible **16B** or before the spring coils are in contact with each other (**Fig. below**)!

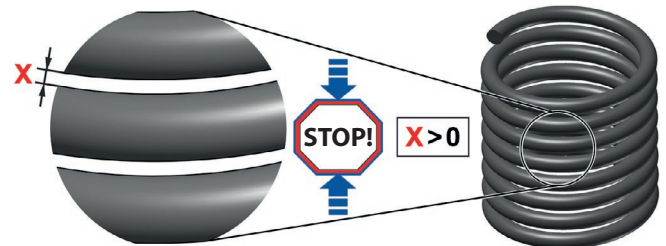

➤ Note that when using the support ring pair [G] they may only move slightly against each other during preloading. Otherwise, stop compressing, release the suspension strut, and check and correct the position of the support ring pair [G]. (**See below**)

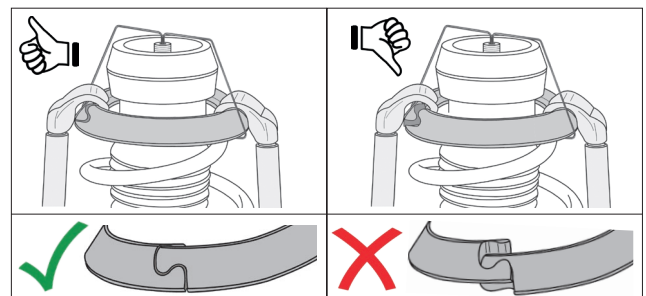

1. Preload the suspension strut in a straight line as shown in **16**. To do this, turn both drive nuts [A2] (27mm) alternately and evenly **clockwise** until the suspension strut can be inserted into the suspension strut clamping hole on the vehicle **17**.

📷 18: Installing the suspension strut into the vehicle.

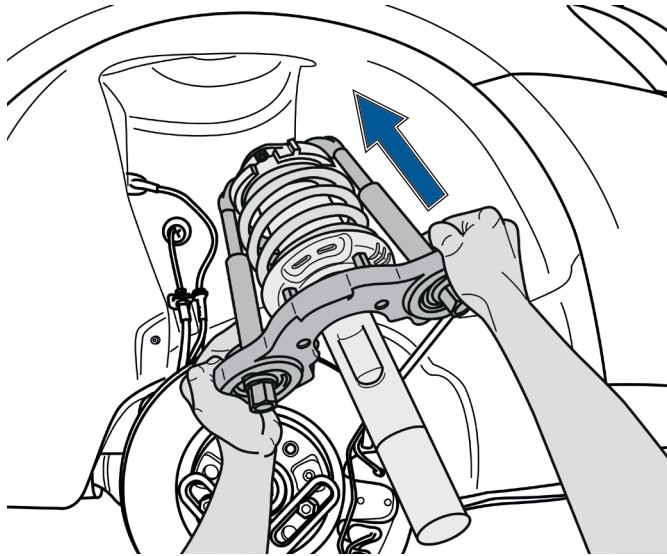

📷 19: Release the spring and take the removal and mounting aid away.

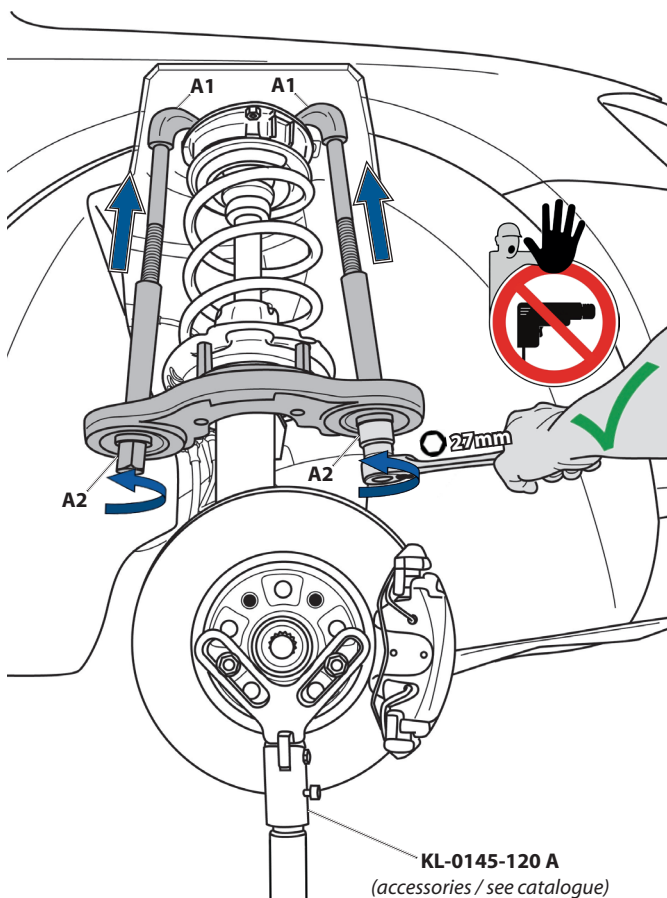

3. Remove the suspension strut from the holding device, insert it in the correct position into the strut clamping bore, and fix it in accordance with the manufacturer's instructions 📷 18.

4. Release the suspension strut in a straight line as shown in 📷 19. For this, turn the two drive nuts [A2] (⌀ 27mm) alternately and evenly anticlockwise until the hooks [A1] are free.

Subsequently, remove the removal and mounting aid from the suspension strut.

5. Perform further work on the vehicle as specified by the manufacturer.

5. CARE / STORAGE

CAUTION

Improper care and storage can damage the removal and mounting aid. Therefore, **never** immerse the internal-type removal and mounting aid in water, solvents, or other cleaning liquids. After use, clean all parts **only** with a dry and clean cleaning cloth. To protect against corrosion, rub all metal parts with a tool care oil or wax. Store the removal and mounting aid and the operating instructions at a dry and clean place.

6. REPAIR

⚠️ WARNING

For safety reasons, ensure that a damaged removal and mounting aid is no longer used for safety reasons! Professional inspection and repair may only be carried out by specially trained specialist personnel at **GEDORE Automotive GmbH**. Improper repair can result in **DEATH** or **SEVERE INJURIES**.

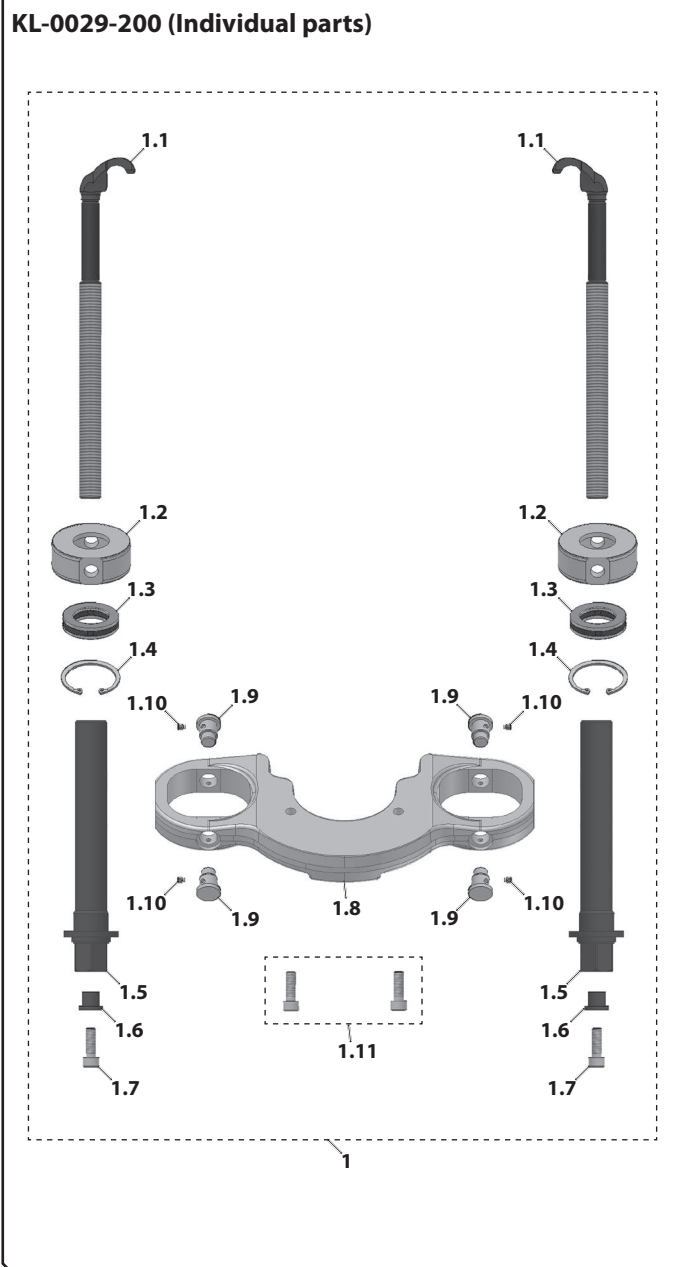
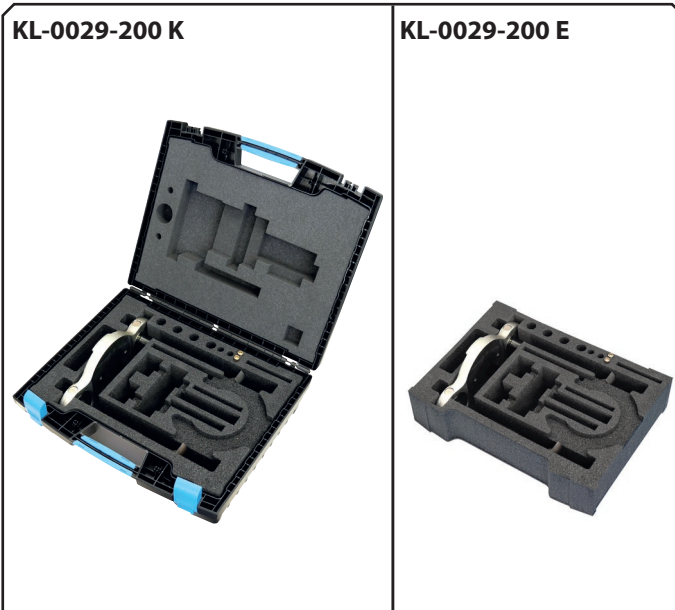

7. INDIVIDUAL PART / KIT OVERVIEW

2.1 KL-0029-200 (E/K) Removal and mounting aid (basic unit) for McPherson suspension struts

Item	Part no.	Description	Qty.
1	KL-0029-200	Removal and mounting aid (basic unit) for McPherson suspension struts	1
1.1	KL-0029-1002 A	Hook (with spindle)	2
1.2	KL-0029-2002	Bearing shell	2
1.3	KL-0029-2003	Axial bearing	2
1.4	KL-0029-2004	Circlip	2
1.5	KL-0029-2006	Clamping nut	2
1.6	KL-0029-1002-1	Extension sleeve	2
1.7	KL-1283-1015	Cap screw M8x35 mm	2
1.8	KL-0029-2001	Base plate	1
1.9	KL-0029-2005	Bolt	4
1.10	KL-0029-2007	Grub screw M5x6 mm	4
1.11	KL-0029-2008	Fixing screw set for support plate, M8x25mm	1

i KL-0029-200 E is in additional foam insert - KL-0029-1090-1 A
KL-0029-200 K is in additional plastic case - KL-0029-2090

8. ENVIRONMENTALLY COMPLIANT DISPOSAL

Dispose of the removal and mounting aid and the packaging material in an environmentally compatible way and in accordance with the legal requirements. If necessary, ask your local authorities about environmentally friendly disposal options.

GEDORE-Werkzeugfabrik GmbH & Co. KG

Remscheider Straße 149
42899 - Remscheid
Postfach 120361
47873 Remscheid
GERMANY

Vertrieb DEUTSCHLAND

☎ +49 (0) 2191 / 596-0
☎ +49 (0) 2191 / 596-230
✉ info@gedore.com
🌐 www.gedore.com

Sales INTERNATIONAL

☎ +49 (0) 2191 / 596-910
☎ +49 (0) 2191 / 596-911
✉ info@gedore.com
🌐 www.gedore.com

GEDORE TOOLS, INC.

Only for USA, Canada & Mexico
Sólo para EE.UU., Canadá y México
Seulement pour les USA, le Canada et le Mexique
7187 Bryhawke Circle, Suite 700, North Charleston, SC 29418, USA

☎ +1-843 / 225 50 15
☎ +1-843 / 225 50 20
✉ info@gedoretools.com
🌐 www.gedoretools.com

Worldwide GEDORE service centers and offices are listed on the Internet at: www.gedore.com

GEDORE Automotive GmbH

Breslauer Straße 41
78166 - Donaueschingen
Postfach 1329
78154 Donaueschingen
GERMANY

Vertrieb DEUTSCHLAND

☎ +49 (0) 771 / 8 32 23-0
☎ +49 (0) 771 / 8 32 23-90
✉ info.gam@gedore.com
🌐 gedore-automotive.com



www.gedore-automotive.com