

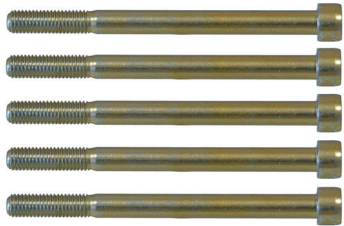

KL-0040-860 / -861 / -862

Wheel Bearing Tool Set Ford Transit/Tourneo



Operating instructions EN
 ⚠ Read and understand before use!

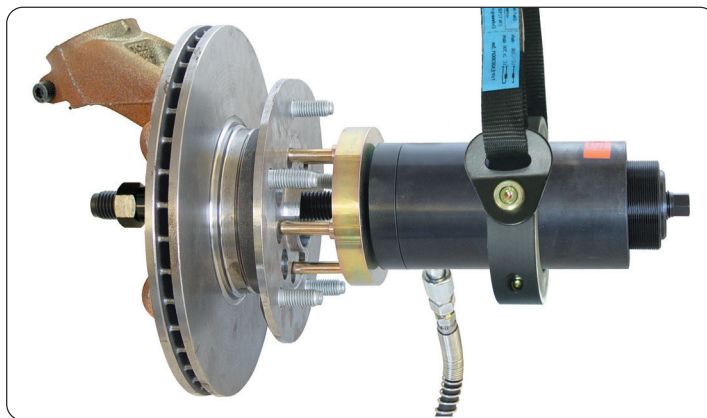
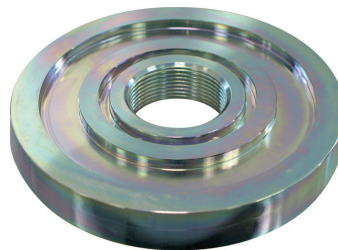
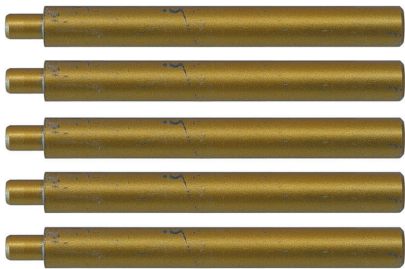

www.gedore-automotive.com



GEDORE Automotive GmbH
 Breslauer Straße 41
 78166 - Donaueschingen
 Postfach 1329
 78154 Donaueschingen - GERMANY

☎ +49 (0) 771 / 8 32 23-0
 ☎ +49 (0) 771 / 8 32 23-90
 ✉ info.gam@gedore.com
 🌐 gedore-automotive.com

GEDORE TOOLS, INC.

Only for USA, Canada & Mexico / Sólo para EE.UU., Canadá y México
 Seulement pour les USA, le Canada et le Mexique
 7187 Bryhawke Circle, Suite 700
 North Charleston, SC 29418, USA

☎ +1-843 / 225 50 15
 ☎ +1-843 / 225 50 20
 ✉ info@gedoretools.com
 🌐 gedore.com

Version 1 - 07/2021



ENGLISH

EN

EN

Manufacturer's address

GEDORE Automotive GmbH

Breslauer Straße 41 // 78166 Donaueschingen - GERMANY

☎ +49 (0)771/83223-71 // ✉ info.gam@gedore.com

Imprint

In the course of improvement and adaptation to the state of the art, we reserve the right to make changes with regard to appearance, dimensions, weights and properties, and performance.

This does not imply any claim to correction or subsequent delivery of already delivered products. Deletions can be made at any time without any legal claim arising.

Instructions for use and safety are not binding. They never substitute for any legal or trade association regulations.

We do not accept any liability for printing errors.

Any reproduction, in whole or in part, requires the prior written consent of **GEDORE Automotive GmbH**.

All rights reserved worldwide. © Copyright by **GEDORE Automotive GmbH**, Donaueschingen (GERMANY)

We refer to our general terms and conditions which
can be found in the imprint at:

www.gedore-automotive.com



Contents

1. FOR YOUR SAFETY	4
1.1 Target group.....	4
1.2 Obligations of the owner.....	4
1.3 Intended use	4
1.4 Reasonably foreseeable misuse	4
1.5 Personal protective equipment.....	5
1.6 Labelling of the warnings.....	5
1.7 Basic warnings	5
1.8 Basic safety instructions	6
1.9 Work environment	7
1.10 Emissions.....	7
1.11 Maintenance	7
1.12 Troubleshooting.....	7
2. PRODUCT DESCRIPTION	8
2.1 KL-0040-860 - Wheel bearing tool set Ford Transit/Tourneo	8
2.1.1 Scope of delivery/component overview.....	8
2.1.2 Specifications.....	8
2.2 KL-0040-861 - Supplementary kit Ford Transit rear axle	9
2.2.1 Scope of delivery/component overview.....	9
2.3 KL-0040-862 - Supplementary kit Ford Transit closed wheel bearings	9
2.3.1 Scope of delivery/component overview.....	9
3. PREPARATION	10
3.1 Checking the scope of delivery	10
3.2 Assembling drive parts	10
3.3 Preparing the vehicle	11
4. TYPICAL APPLICATIONS	11
4.1 Removing the wheel bearing unit at the front axle with front/all-wheel drive , using KL-0040-860	11
4.1.1 Pulling off the wheel hub bearing unit with brake disc	11
4.1.2 Forcing off the brake disc.....	13
4.1.3 Forcing out the wheel hub.....	14
4.1.4 Forcing in the wheel hub.....	16
4.2 Removing the wheel hub bearing unit at the front axle with rear drive , using KL-0040-860 + KL-0040-862	17
4.2.1 Pulling off the wheel hub bearing unit with brake disc	17
4.2.2 Forcing off the brake disc.....	19
4.3 Forcing off the brake disc on the rear axle with front drive , using KL-0040-860 + KL-0040-861	21
5. CARE AND STORAGE	22
6. REPAIR	22
7. ENVIRONMENTALLY FRIENDLY DISPOSAL	22

1. FOR YOUR SAFETY



Read and understand these operating instructions **before using** the wheel bearing tool, and observe all safety and warning instructions! Misuse can result in **DEATH** or **SEVERE INJURIES** ! These operating instructions are an integral part of the wheel bearing tool. Keep them at a safe place for future reference, and always pass them on to subsequent users of the wheel bearing tool! The wheel bearing tool complies with the recognised rules of technology as well as the relevant safety regulations!

1.1 Target group

These operating instructions are **exclusively** intended for skilled personnel in specialised motor vehicle workshops!

The wheel bearing tool **may only be** used by skilled personnel in specialised motor vehicle workshops who are familiar with the basic regulations on work safety and accident prevention!

❗ **Never** allow unauthorised, inexperienced persons, minors and children, or persons with limited physical, sensory, and mental abilities to use the wheel bearing tool!

1.2 Obligations of the owner

Pursuant to the German Ordinance on Industrial Safety and Health (*BetrSichV*), employers are obliged to provide their employees with safe work equipment in accordance with the recognized rules of technology and the relevant safety regulations!

❗ The owner of the wheel bearing tool **must** ensure that **only** trained personnel in specialised vehicle workshops use the wheel bearing tool!

❗ The owner of the wheel bearing tool **must** ensure that the instructions for use are available to the user and that the user has completely read and understood the instructions for use **before** using the wheel bearing tool!

❗ The owner of the wheel bearing tool **must** ensure that the user is familiar with the basic regulations on work safety and accident prevention, and that the personal protective equipment is available to him/her!

1.3 Intended use

The wheel bearing tool ...

❗ **may only** be used for installing or removing wheel bearing units as well as wheel hubs and brake discs!

❗ **may only** be used on vehicles as specified in **Chapter 2. - Product description!**

❗ **may only** be used to a **max. load of 28 tonnes!**

❗ **may only** be used with a manual drive or a manually operated **GEDORE Automotive** hydraulic cylinder/pump combination with a pressure gauge for safe pressure control!

❗ **may only** be used in the way described in these operating instructions!

⚠ Any other use can result in **DEATH** or **SEVERE INJURIES** !

1.4 Reasonably foreseeable misuse

The wheel bearing tool ...

❗ **must never** be used to remove and install silent blocks!

❗ **must never** be used for purposes other than those for which it is intended!

❗ **must never** be used with a drive other than that intended for it!

❗ **must never** be used with a machine-operated hydraulic cylinder/pump combination!

❗ **must never** be used for batch processing with many forcing in/out processes within a few minutes!

❗ **must never** be used with a bridged, modified, or removed safety device!

❗ **must never** be modified, converted, or used for other purposes without authorisation!

⚠ Use the wheel bearing tool **always** as intended. Any other use can result in **DEATH** or in **SEVERE INJURIES**!

1.5 Personal protective equipment

For your safety, **always** wear personal protective equipment when using the wheel bearing tool! The wheel bearing tool can bring about mechanical hazards, such as crushing, cutting and shock injuries.



Always wear **EYE PROTECTION** (for example to DIN EN 166, OSHA 29 CFR 1910.133, ANSI Z87) when using the wheel bearing tool to protect yourself against flying parts or particles!

When using the wheel bearing tool, flying parts or particles can cause **SEVERE INJURIES** to your **eyes!**



Always wear **PROTECTIVE GLOVES** (for example to DIN EN 388, OSHA 29 CFR 1910.138, ANSI 105) when using the wheel bearing tool to protect yourself against sharp edges and crushing between parts!

When working with the wheel bearing tool, sharp edges and crushing between parts can cause **SEVERE INJURIES** to your **hands!**



Always wear **SAFETY SHOES** (for example to DIN EN ISO 20345, OSHA 29 CFR 1910.136, ANSI Z41) when using the wheel bearing tool to protect yourself against dropping parts!

When working with the wheel bearing tool, dropping parts can cause **SEVERE INJURIES** to your **feet and toes!**

EN

1.6 Labelling of the warnings

Warnings warn of potential **hazards**. **Always** observe these warnings to avoid **DEATH** or **INJURIES!**

For better differentiation, warnings in these operating instructions are classified as follows:

Warning sign	Meaning
	Indicates a hazardous situation which, if not avoided, could cause DEATH or SEVERE INJURIES .
	Indicates a hazardous situation which, if not avoided, could cause MODERATE or MINOR INJURIES .
	Indicates a situation which, if not avoided, can cause damage to the tool or an object in its vicinity.
	Note on important information and useful tips.

1.7 Basic warnings

⚠ WARNING - Danger to life from MISUSE

MISUSE can cause the wheel bearing tool to slip, break and thus drop or be hurled about. This can cause **DEATH** or **SEVERE INJURIES!**

Read and understand these operating instructions **before using** the wheel bearing tool, and observe all safety and warning instructions for **safe use!**

Always work with the wheel bearing tool in accordance with the basic regulations on work safety and accident prevention!

Only use the wheel bearing tool as described in these operating instructions!

Always observe the vehicle-specific application procedures in the vehicle manufacturer's repair guide!

Never use the wheel bearing tool if it is damaged or has loose parts or unauthorised modifications!

Never use the wheel bearing tool with an inadmissible drive. Drive it **exclusively** with a manual drive or a manually driven **GEDORE Automotive** hydraulic cylinder/pump combination with pressure gauge for safe pressure control!

Never use the wheel bearing tool for batch processing with numerous forcing in/out processes within a few minutes!

Always wear your personal protective equipment (*safety goggles, protective gloves, safety shoes*) during work!

Never hit the wheel bearing tool with a hammer or anything similar!

⚠ WARNING - Danger to life from OVERLOAD

MISUSE can cause the wheel bearing tool to slip, break and thus drop or be hurled about. This can cause **DEATH** or **SEVERE INJURIES!**

- ✔ **Never** exceed the **maximum loading capacity** of the wheel bearing tool!
- ✔ **Never** use the wheel bearing tool if it is damaged or has loose parts or unauthorised modifications!
- ✔ **Never** use the wheel bearing tool with a machine-operated drive or a machine-operated hydraulic cylinder / pump combination!
- ✔ Use the wheel bearing tool **exclusively** with a manual drive or a manually operated **GEDORE Automotive** hydraulic cylinder/ pump combination with a pressure gauge for reliable pressure control!
- ✔ **Never** use the wheel bearing tool for batch processing with numerous forcing in/out processes within a few minutes!
- ✔ **Always** wear your personal protective equipment (*safety goggles, protective gloves, safety shoes*) during work!

⚠ CAUTION - Danger of injury from FALLING

There is a risk of the wheel bearing tool **DROPPING** during preparation and use. This can cause **MEDIUM** or **LIGHT INJURIES!**

- ✔ Avoid dropping the wheel bearing tool **at all costs**, especially when it is under load!
- ✔ **Always** make sure that the wheel bearing tool is securely attached to the spring!
- ✔ **As a precaution**, secure the wheel bearing tool against dropping, for example using the safety retaining belt - **KL-0040-2890** or the mounting device - **KL-0040-288!**
- ✔ **Never** leave the wheel bearing tool unattended in loaded condition on the wheel bearing!
- ✔ Put down the wheel bearing tool **safely** to prevent it from dropping (for example on a workbench)!
- ✔ **Always** wear your personal protective equipment (*safety goggles, protective gloves, safety shoes*) during work!

ATTENTION - Risk of DAMAGE

Vehicle, wheel bearing, and wheel bearing tool can be **DAMAGED**.

- ✔ **Always** install the wheel bearing in the installation position specified by the manufacturer!
- ✔ **Always** observe vehicle-specific application procedures in the vehicle manufacturer's repair guide.
- ✔ **Never** use the wheel bearing tool for batch processing with numerous forcing in/out processes within a few minutes!
- ✔ **Never** clamp the wheel bearing tool in a vice.

1.8 Basic safety instructions

For your safety, **always** observe the following safety precautions when using the wheel bearing tool in order to avoid injuries and material damage caused by misuse or unsafe handling.

- ✔ Read and understand these operating instructions **before using** the wheel bearing tool, and observe all safety and warning instructions for **safe use!**
- ✔ **Always** observe the vehicle-specific application procedures in the vehicle manufacturer's repair guide!
- ✔ **Always** work with the wheel bearing tool in accordance with the basic regulations on work safety and accident prevention!
- ✔ **Never** use the wheel bearing tool when you are tired or under the influence of alcohol, drugs, or medicaments!
- ✔ **Before each use**, check the wheel bearing tool **carefully** for damage, loose parts, or unauthorised modifications. **Never** use it if you notice any such deficiencies!
- ✔ Use **only genuine GEDORE Automotive** spare parts and accessories!
- ✔ Due to its high weight, **always** carry, lift, and position the wheel bearing tool with the help of a second skilled person!
- ✔ **Before using** the wheel bearing tool, make sure that **no** unauthorised persons are in the immediate environment!
- ✔ **Always** observe the **max. loading capacity** when using the wheel bearing tool, and **never** exceed it!
- ✔ **Always** keep hair, clothing, and gloves away from moving parts!

- ✔ **Never** use the wheel bearing tool with an unauthorised drive. Drive it **only** with an approved drive!
- ✔ **Always** wear your personal protective equipment (*safety goggles, protective gloves, safety shoes*) during work!
- ✔ Interrupt your work **immediately** if you are unsure about using the wheel bearing tool, and contact **GEDORE Automotive GmbH if necessary!**
- ✔ **Always** use the perforated disc set as intended. Non-compliance will invalidate any warranty claim and may significantly reduce its durability!

1.9 Work environment

For your safety, **only** use the wheel bearing tool in a safe working environment.

- ✔ The workplace **must** be clean and tidy.
- ✔ The workplace **must** be sufficiently large and illuminated.
- ✔ The workplace **must** be on a solid and non-skidding floor.
- ✔ The workplace **must** be safeguarded against access of unauthorised persons.
- ✔ The workplace **must** have a room temperature between -10°C and +40°C.

1.10 Emissions

Molybdenum disulphide paste and hydraulic oil can drip or escape when using the wheel bearing tool and thus pose a hazard to the environment.

- ✔ **Immediately** remove leaking hydraulic oil as well as excess molybdenum disulphide paste (using oil binding agents or a rag, for example).
- ✔ In case of skin contact with hydraulic oil, clean the affected area **immediately** with degreasing soap and water.
- ✔ Dispose of pollutants such as hydraulic oil and molybdenum disulphide paste in an **environmentally friendly** manner.
- ✔ Safety data sheets *as per (EC) Ordinance No. 1907/2006 about hydraulic oil (Alsus Hyd HLP 32)* and molybdenum disulphide paste (**MOLYKOTE(R) G-N PLUS PASTE**) can be found on the manufacturer's website in the internet (**World Wide Web**).

1.11 Maintenance

Missing and improper maintenance can cause damage and breakage of the wheel bearing tool. This can cause **DEATH** or **SEVERE INJURIES!** Perform maintenance on the wheel bearing tool **at regular intervals** and **only** when the tool is depressurised and/or de-energised!

Prior to each use:

- ✔ **Prior to each use**, check the wheel bearing tool **carefully** for damage, loose parts or unauthorised modifications!
- ✔ **Prior to each use** of the wheel bearing tool, check the pull spindle for contamination and damage. If necessary, clean it and subsequently lubricate it **only** with molybdenum disulphide paste! (For example, **GEDORE Automotive** molybdenum disulphide paste - **KL-0014-0030**)

Recommended: Every 12 months:

- ✔ Have the wheel bearing tool professionally checked **every 12 months** by authorised **GEDORE Automotive GmbH** specialists!

1.12 Troubleshooting

Only perform troubleshooting on the wheel bearing tool when it is depressurised!

Problem: Hydraulic oil escapes from the hydraulic coupling between hydraulic cylinder and hand pump.

Reason: Hydraulic coupling contaminated or loose.

Remedy: Clean and retighten the hydraulic coupling. Top up lacking hydraulic oil (**HLP 32**) at the hand pump.

2. Product description

2.1 KL-0040-860 - Wheel bearing tool set Ford Transit/Tourneo

Fits with the front axle on Ford Transit/Tourneo (2000-2006 / 2006-2014 / 2014 onwards) with front and all-wheel drive and a hole circle diameter of 97.5 mm and 111 mm of the brake disc fastening screws.

The wheel bearing tool set enables quick and professional removal of the bolted wheel bearing unit with wheel hub and brake disc on the front axle, as well as subsequent removal and insertion of the wheel hub on the wheel bearing unit. For example, this is required when replacing the wheel bearing and brake discs, as these are located behind the wheel hub. All work can be carried out directly on the vehicle within a few minutes. Time-consuming removal and installation of the wheel bearing housing as well as the resulting wheel alignment are not necessary.

Recommended accessories:

KL-0040-861 - Supplementary kit Ford Transit rear axle

KL-0040-862 - Supplementary kit Ford Transit, closed wheel bearings

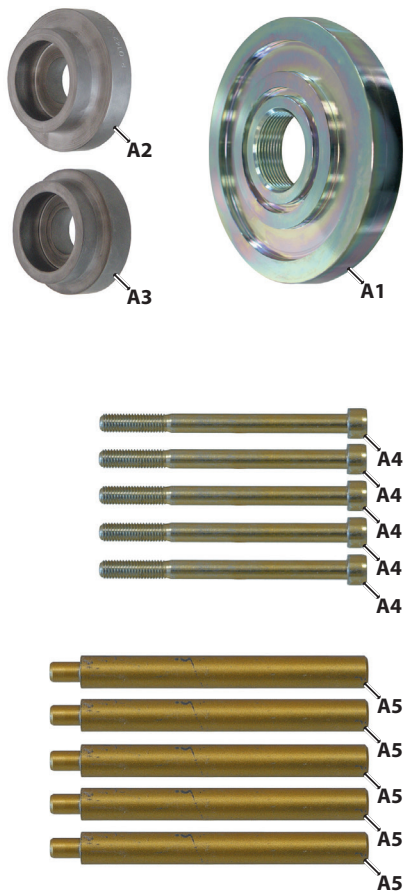

2.1.1 Scope of delivery / component overview

Pos.	Part no.	Description	Qty.
A1	KL-0040-8501 A	Thrust ring Ø 137mm	1
A2	KL-0040-8601	Thrust disc diameter 77mm	1
A3	KL-0040-8602	Thrust disc diameter 68mm	1
A4	KL-0039-1823-4	Cheese-head screw M10 x 120	5
A5	KL-0040-8503	Mandrel	5

2.1.2 Specifications

Max. load: 28t

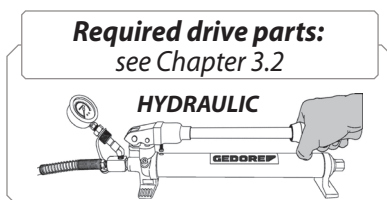

2.2 KL-0040-861 - Supplementary kit Ford Transit rear axle

Fits with the rear axle on Ford Transit/Tourneo (YOM 2006-2014) with front-wheel drive and a hole circle diameter of 160 mm of the brake disc fastening screws.

The supplementary kit enables the wheel hub bearing unit on the brake disc of the rear axle to be forced off quickly and professionally. For example, this is required when replacing the wheel bearing and brake discs, as these are located behind the wheel hub.

Required set of tools + drive parts:

KL-0040-860 - Wheel hub tool set Ford Transit, **KL-0040-2800** - Hydraulic cylinder 28 tonnes, **KL-0215-35 M28** - Hydraulic pump, **KL-0040-2812-1** - Pull/thrust spindle M24, **KL-0040-2812-2** - Tensioning nut M24

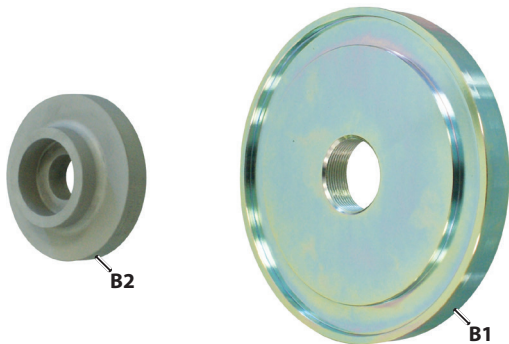

2.2.1 Scope of delivery / component overview

Pos.	Part no.	Description	Qty.
B1	KL-0040-8501 A	Thrust ring Ø 186mm	1
B2	KL-0040-8601	Thrust disc diameter 93mm	1

2.3 KL-0040-862 - Supplementary kit Ford Transit, closed wheel bearings

Fits with the front axle on Ford Transit/Tourneo (as of YOM 2014) with rear drive and a hole circle diameter at the brake disc fastening screws of 97.5mm and 111 mm. Particularly suitable for vehicles with wheel bearings without centre bore in closed design on the front axle.

This supplementary kit enables quick and professional removal of the bolted wheel bearing unit with wheel hub and brake disc on the front axle, as well as subsequent removal and insertion of the wheel hub on the wheel bearing unit, especially for closed wheel bearings without centre bore. For example, this is required when replacing the wheel bearing and brake discs, as these are located behind the wheel hub. All work can be carried out directly on the vehicle within a few minutes. Time-consuming removal and installation of the wheel bearing housing as well as the resulting wheel alignment are not necessary.

Required set of tools + drive parts:

KL-0040-860 - Wheel hub tool set Ford Transit, **KL-0040-2800** - Hydraulic cylinder 28t, **KL-0215-35 M28** - Hydraulic pump, **KL-0040-2812-1** - Pull/thrust spindle M24

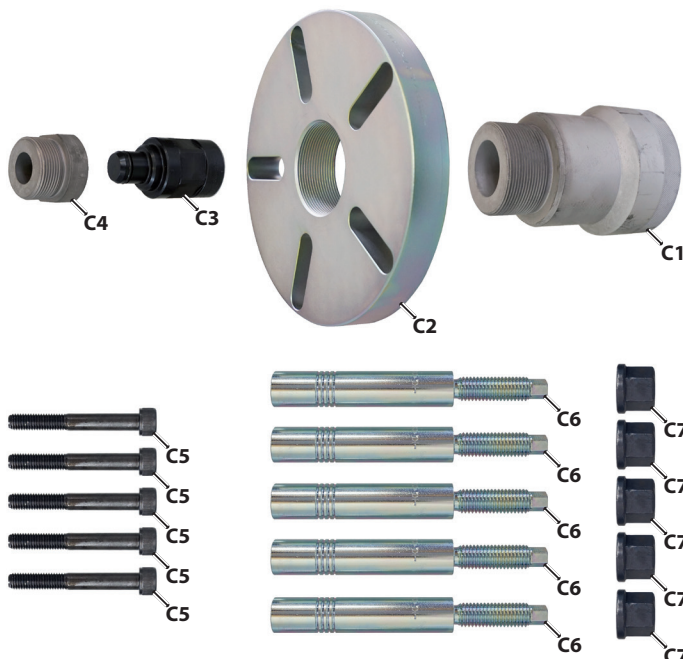

2.3.1 Scope of delivery / component overview

Pos.	Part no.	Description	Qty.
C1	KL-0174-572	Adapter 2-1/4" to 2-3/4"	1
C2	KL-0174-330	Perforated disc size 3 (5 holes)	1
C3	KL-0040-2812-5	Thrust nut M24	1
C4	KL-0040-8621	Pressure adapter	1
C5	KL-0186-9000-3	Cheese-head screw M10x75	5
C6	KL-0174-764 A	Pull bolt type M, M14x1.5mm	5
C7	KL-0174-701	Hexagon collar nut M14	5

3. PREPARATION

⚠ WARNING

Misuse or overloading the wheel bearing tool can cause it to slip, break and thus drop or be hurled about. This can cause **DEATH** or **SEVERE INJURIES!**

- ✔ **Prior to using** the wheel bearing tool, read and understand **all** safety instructions and warnings listed in **Chapter 1** and **always observe** them **for safe use!**
- ✔ Use the wheel bearing tool **as intended** and described in these operating instructions. **Always** observe the vehicle-specific application procedures in the repair manual of the vehicle manufacturer!
- ✔ **Before each use**, check the wheel bearing tool **carefully** for damage, loose parts, or unauthorised modifications. **Never** use it if you notice any such deficiencies!
- ✔ **Always** wear your personal protective equipment (*safety goggles, protective gloves, safety shoes*) during work!

3.1 Checking the scope of delivery

Prior to using the wheel bearing tool, check to ensure that all the parts included in the scope of delivery (*see chapter 2.*) are present, and follow the instructions below.

3.2 Assembling drive parts

⚠ WARNING

Using a machine-operated drive can cause the wheel bearing tool to slip, break and thus drop or be hurled about. This can cause **DEATH** or **SEVERE INJURIES!**

- ✔ Use the wheel bearing tool **exclusively** with a manual drive or a manually operated **GEDORE Automotive** hydraulic cylinder / pump combination with a pressure gauge for reliable pressure control!

1) Assemble the required drive parts for the wheel bearing tool as shown in **📷 1**.

📷 1) *For other pressure plates see the GEDORE Automotive catalogue.*

📷 1: Required drive parts



📷2: Preparing hydr. cyl. [Z2].

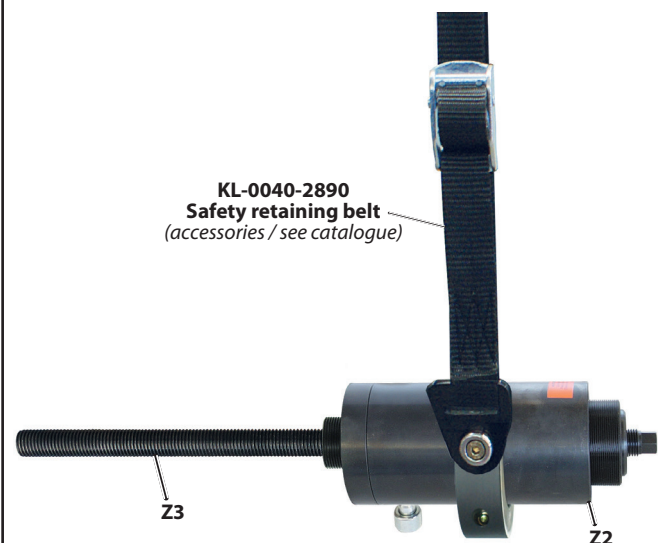

📷3: Unscrewing the fastening screws.

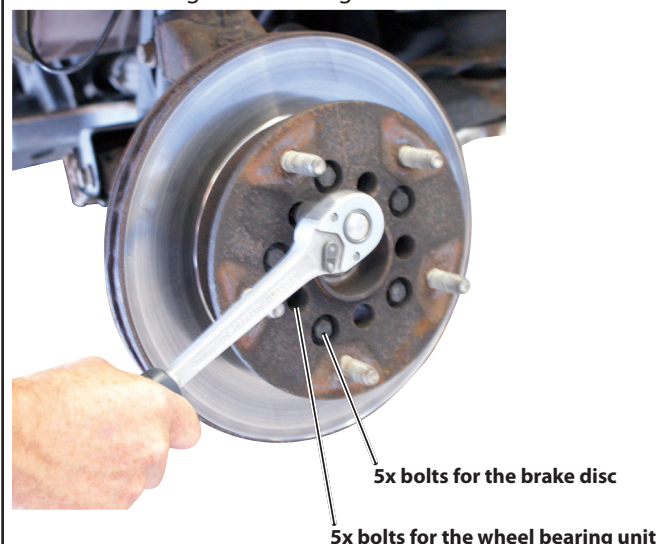

📷4: Screwing cheese-head screws [A4] into steering knuckles.

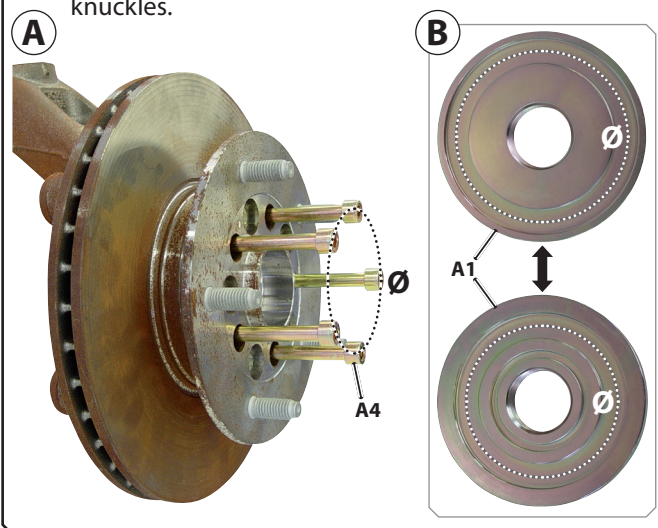

3.3 Preparing the vehicle

- 1) Lift the vehicle safely and prepare all necessary parts for the subsequent work in accordance with the manufacturer's instructions.

For example:

Remove wheel, remove brake caliper, remove drive shaft if necessary.

4. TYPICAL APPLICATIONS

4.1 Removing the wheel bearing unit at the front axle with front/all-wheel drive, using KL-0040-860

Preparing the tool

- 1) Prepare the hydraulic cylinder [Z2] for the further work as shown in 📷2.

ⓘ The safety retaining belt - **KL-0040-2890**, which is available as an *accessory*, or the mounting device - **KL-0040-288** makes it possible to secure the wheel bearing tool against dropping.

4.1.1 Pulling off the wheel hub bearing unit with brake disc

This typical application describes **pulling the wheel bearing unit with brake disc off the steering knuckle** at the front axle on vehicles with front and all-wheel drive. In connection with the wheel bearing tool set - **KL-0040-860**.

ATTENTION

If the cheese-head screws [A4] are screwed in at different heights, there is a risk that the contact of the thrust ring [A1] is askew, which can damage the wheel bearing tool.

➤ **Ensure** that the cheese head screws are screwed to the same height [A4].

- 1) To start with, unscrew **only** the fastening screws of the wheel bearing unit. 📷3

Next, screw the five cheese head screws [A4] at the same height as shown in 📷4A into the mounting holes in the wheel bearing unit that became free.

ATTENTION

There is a risk of damaging the wheel bearing tool if the thrust ring [A1] is positioned with the wrong side on the cheese head screws [A4].

➤ The thrust ring [A1] has two application sides. Please bear in mind that the thrust ring [A1] must be aligned as required by the hole circle Ø of the cheese head screws [A4] that have already been screwed in.

- 2) First check which **groove** (front or back) on the thrust ring [A1] is needed 📷4B. To do this, hold the thrust ring [A1] against the cheese head screws [A4] 📷4A that have already been screwed in, and align it to match them.

📷 5: Assembling and positioning the wheel bearing tool.

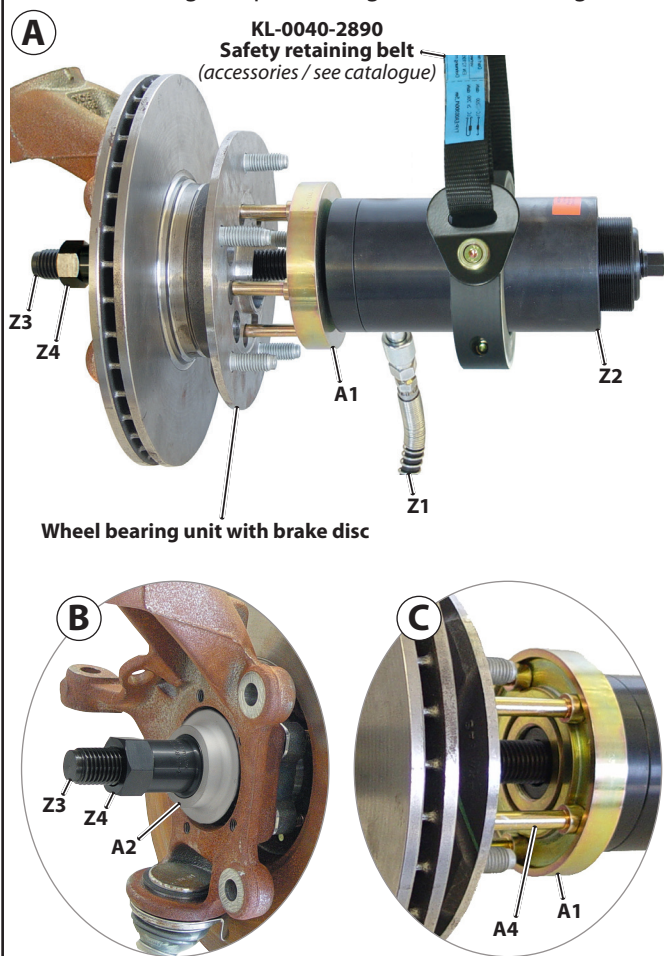

📷 6: Pulling off the wheel bearing unit with brake disc.

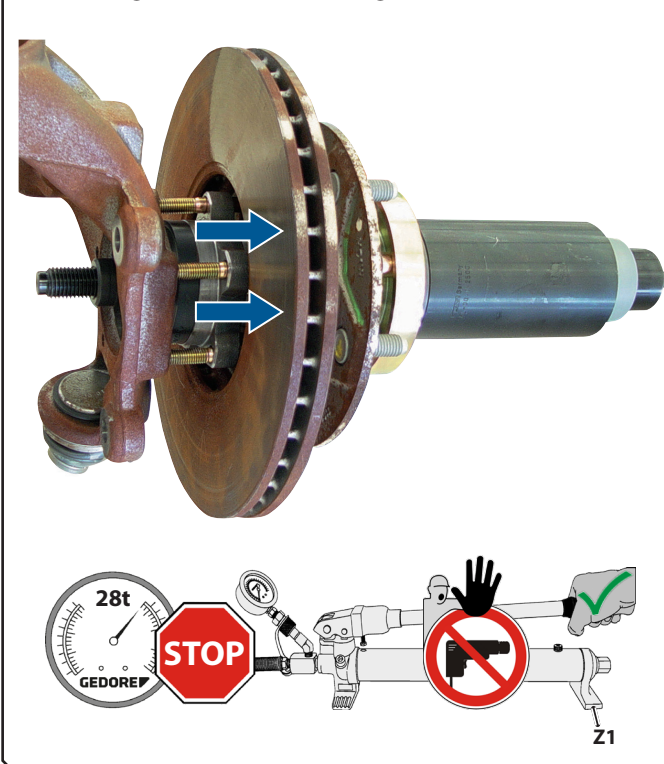

3) Mount the hydraulic cylinder [Z2] with all necessary components on the wheel bearing unit with brake disc as shown in 📷5A+B.

ⓘ Ensure that the cheese-head screws [A4] are engaged completely and neatly in the groove at the thrust ring [A1] 📷5C.

ⓘ Ensure that the thrust disc [A2] is orientated in the correct position 📷5B.

⚠️ WARNING

There is the risk of the wheel bearing tool breaking when a machine-operated drive is used. Parts flying about can cause **DEATH** or **SEVERE INJURIES**.

➤ Use the wheel bearing tool exclusively with a manually operated **GEDORE Automotive** hydraulic cylinder/pump combination with a manometer for reliable pressure control!

4) Connect the hydraulic pump [Z1] with the hydraulic cylinder [Z2].

⚠️ CAUTION

There is a risk of the wheel bearing tool dropping when the wheel bearing unit with brake disc is pulled off. This can cause **MEDIUM** or **LIGHT INJURIES!**

➤ As a precaution, secure the perforated disc set on the vehicle against dropping, for example using the safety retaining belt - **KL-0040-2890** or the mounting device - **KL-0040-288!**

⚠️ WARNING

During the removal of wheel bearing unit with brake disc there is a breaking risk of the pull spindle, and thus the risk of parts being hurled about. This can cause **DEATH** or **SEVERE INJURIES**.

➤ **Never** exceed the **maximum load** of the wheel bearing tool of **28t!**

➤ **Constantly** watch the pressure on the pressure gauge of the hydraulic pump [Z1] while you are pulling off.

➤ **Never** stand in the axial extension of the pull spindle [Z3] while you are pulling off.

5) While you are operating the hydraulic pump [Z1], watch the pressure on the pressure gauge and pull the wheel bearing unit with brake disc off the steering knuckle. 📷6

ⓘ The maximum stroke of the hydraulic cylinder [Z2] is 50 mm! As soon as this value is reached: Interrupt the forcing process, relieve the pressure at the hydraulic pump [Z1], re-tighten the clamping nut [Z4] until it is fully applied, and continue the forcing process.

6) Dismount the wheel bearing tool and continue with **Chapter 4.1.2 / Forcing off the brake disc**.

📷7: Screwing cheese-head screws [A4] into brake disc.

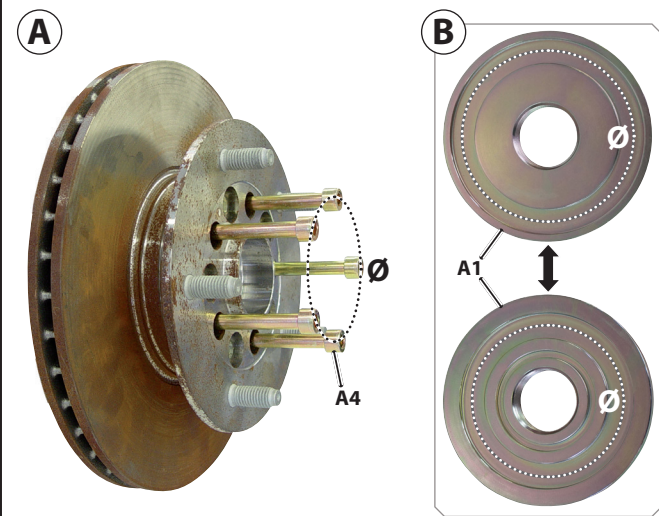

📷8: Assembling and positioning the wheel bearing tool.

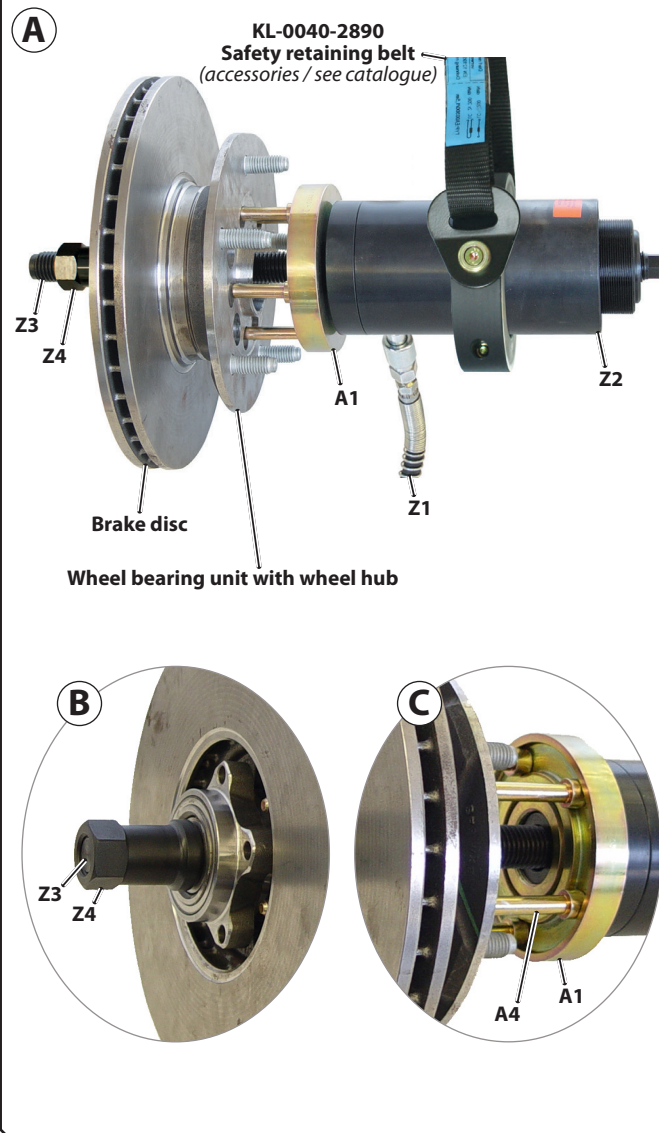

4.1.2 Forcing off the brake disc

This typical application describes the **forcing of the brake disc off the wheel bearing unit** on the front axle of vehicles with front and all-wheel drive. In connection with the wheel bearing tool set - **KL-0040-860**.

ATTENTION

If the cheese-head screws [A4] are screwed in at different heights, there is a risk that the contact of the thrust ring [A1] is askew, which can damage the wheel bearing tool.

➤ **Ensure** that the cheese head screws are screwed to the same height [A4].

1) To start with, unscrew the fastening screws of the brake disc. (See 📷3)

Next, screw the five cheese head screws [A4] at the same height as shown in 📷7A into the mounting holes in the brake disc that became free.

ATTENTION

There is a risk of damaging the wheel bearing tool if the thrust ring [A1] is positioned with the wrong side on the cheese head screws [A4].

➤ The thrust ring [A1] has two application sides. Please bear in mind that the thrust ring [A1] must be aligned as required by the hole circle Ø of the cheese head screws [A4] that have already been screwed in.

2) First check which **groove** (front or back) on the thrust ring [A1] is needed 📷7B. To do this, hold the thrust ring [A1] against the cheese head screws [A4] 📷7A that have already been screwed in, and align it to match them.

3) Mount the hydraulic cylinder [Z2] with all necessary components on the wheel bearing unit with brake disc as shown in 📷8A+B.

ⓘ Ensure that the cheese-head screws [A4] are engaged completely and neatly in the groove at the thrust ring [A1] 📷8C.

⚠WARNING

There is the risk of the wheel bearing tool breaking when a machine-operated drive is used. Parts flying about can cause **DEATH** or **SEVERE INJURIES**.

➤ Use the wheel bearing tool exclusively with a manually operated **GEDORE Automotive** hydraulic cylinder/pump combination with a manometer for reliable pressure control!

4) Connect the hydraulic pump [Z1] with the hydraulic cylinder [Z2].

📷 9: Forcing the brake disc off the wheel bearing unit.

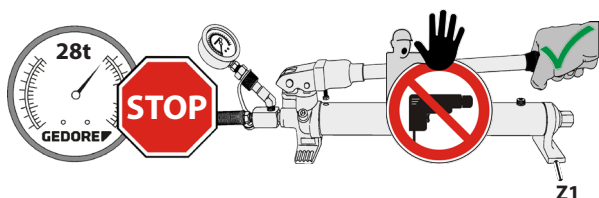
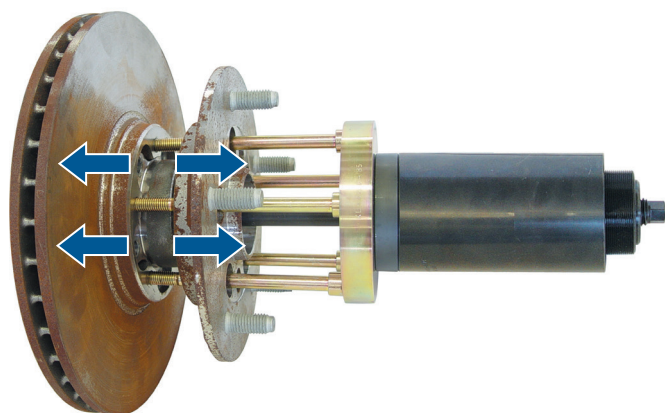

⚠ CAUTION

There is a risk of the wheel bearing tool dropping when the brake disc is forced off. This can cause **MEDIUM** or **LIGHT INJURIES!**

➤ Put down the wheel bearing tool **safely** to prevent it from dropping (for example on a workbench)!

⚠ WARNING

When forcing off the brake disc, there is a risk of the pull spindle breaking and parts being hurled about. This can cause **DEATH** or **SEVERE INJURIES**.

➤ **Never** exceed the **maximum load** of the wheel bearing tool of **28t!**

➤ **Constantly** watch the pressure on the pressure gauge of the hydraulic pump [Z1] while you are forcing off.

➤ **Never** stand in the axial extension of the pull spindle [Z3] while you are forcing off.

5) While you are operating the hydraulic pump [Z1], watch the pressure on the pressure gauge and force the brake disc off the wheel hub bearing unit. 📷 9

ⓘ The maximum stroke of the hydraulic cylinder [Z2] is 50mm! As soon as this value is reached: Interrupt the forcing process, relieve the pressure at the hydraulic pump [Z1], re-tighten the clamping nut [Z4] until it is fully applied, and continue the forcing process.

6) Remove the wheel bearing tool and continue with **Chapter 4.1.3 / Forcing out the wheel hub**.

📷 10: Inserting mandrels [A5] into the wheel bearing unit.

A

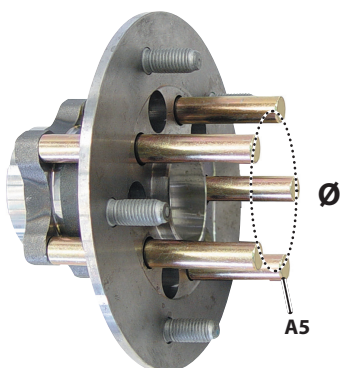

B

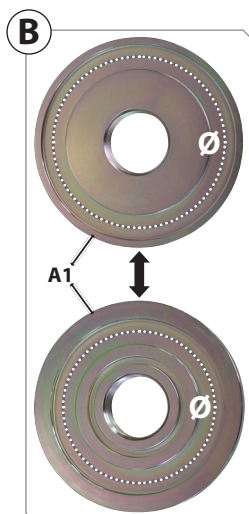

4.1.3 Forcing out the wheel hub

This typical application describes the **forcing the wheel hub out of the wheel bearing unit** on the **front axle** of vehicles with **front and all-wheel drive**. In connection with the wheel bearing tool set - **KL-0040-860**.

1) Insert the five mandrels [A5] completely as shown in 📷 10A into the mounting holes of the wheel bearing unit.

⚠ ATTENTION

There is a risk of damaging the wheel bearing tool if the thrust ring [A1] is positioned with the wrong side on the mandrels [A5].

➤ The thrust ring [A1] has two application sides. Please bear in mind that the thrust ring [A1] must be aligned as required by the hole circle Ø of the mandrels [A5] that have already been inserted.

2) First check which **groove** (front or back) on the thrust ring [A1] is needed 📷 10B. To do this, hold the thrust ring [A1] against the mandrels [A5] 📷 10A that have already been screwed in, and align it to match them.

📷 11: Assembling and positioning the wheel bearing tool.

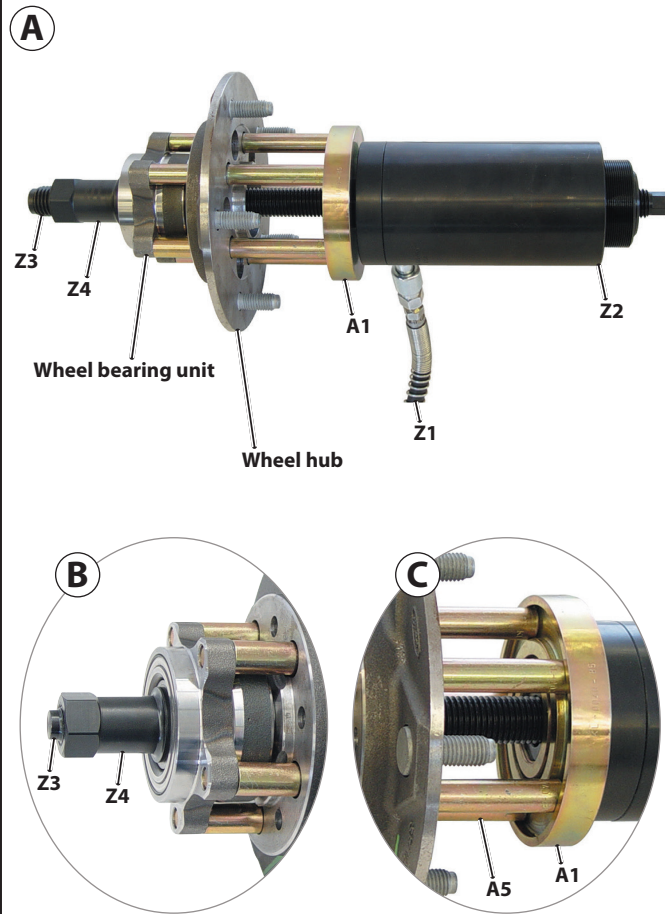

📷 12: Forcing the wheel hub out of the wheel bearing unit.

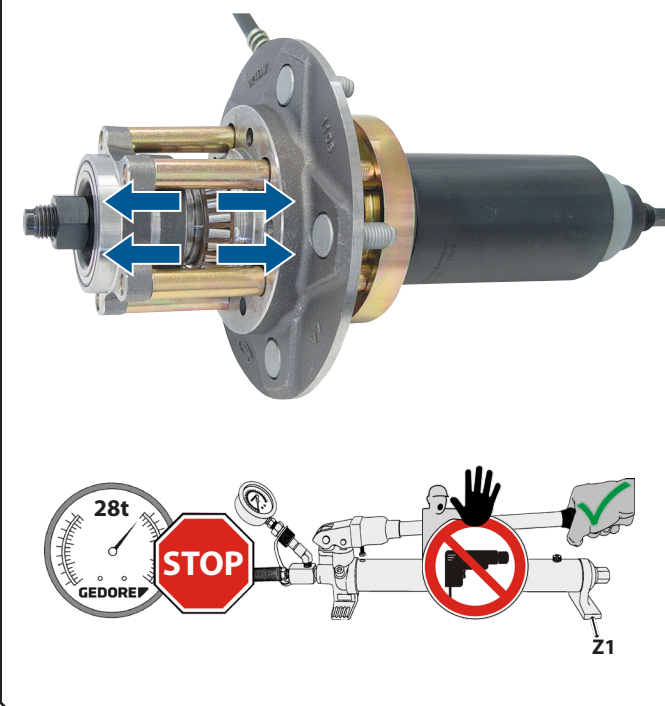

3) Mount the hydraulic cylinder [Z2] with all necessary components on the wheel bearing unit with wheel hub as shown in **📷 11A+B**.

ⓘ Ensure that the mandrels [A5] are engaged completely and neatly in the groove at the thrust ring [A1] **📷 11C**.

⚠️ WARNING

There is the risk of the wheel bearing tool breaking when a machine-operated drive is used. Parts flying about can cause **DEATH** or **SEVERE INJURIES**.

➤ Use the wheel bearing tool exclusively with a manually operated **GEDORE Automotive** hydraulic cylinder/pump combination with a manometer for reliable pressure control!

4) Connect the hydraulic pump [Z1] with the hydraulic cylinder [Z2].

⚠️ CAUTION

There is a risk of the wheel bearing tool dropping when the wheel hub is forced off. This can cause **MEDIUM** or **LIGHT INJURIES!**

➤ Put down the wheel bearing tool **safely** to prevent it from dropping (for example on a workbench)!

⚠️ WARNING

When forcing off the wheel hub, there is a risk of the pull spindle breaking and parts being hurled about. This can cause **DEATH** or **SEVERE INJURIES**.

➤ **Never** exceed the **maximum load** of the wheel bearing tool of **28t!**

➤ **Constantly** watch the pressure on the pressure gauge of the hydraulic pump [Z1] while you are forcing out.

➤ **Never** stand in the axial extension of the pull spindle [Z3] while you are forcing out.

5) While you are operating the hydraulic pump [Z1], watch the pressure on the pressure gauge and force the wheel hub out of the wheel bearing unit. **📷 12**

ⓘ The maximum stroke of the hydraulic cylinder [Z2] is 50mm! As soon as this value is reached: Interrupt the forcing process, relieve the pressure at the hydraulic pump [Z1], re-tighten the clamping nut [Z4] until it is fully applied, and continue the forcing process.

ⓘ If necessary, you may have to remove the inner bearing race from the wheel hub.

6) Remove the wheel bearing tool and continue with **Chapter 4.1.4 / Forcing in the wheel hub**.

📷 13: Assembling and positioning the wheel bearing tool.

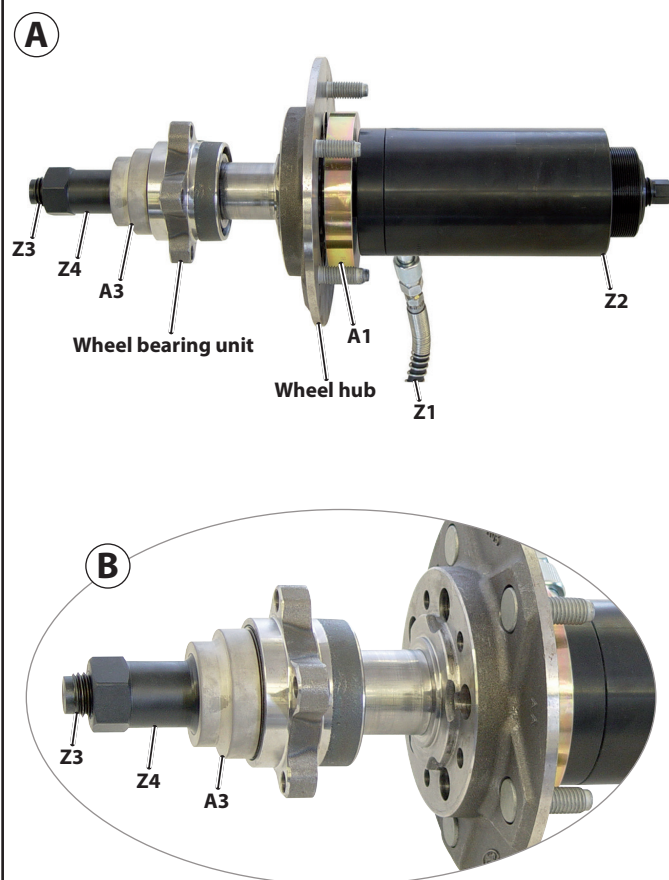

📷 14: Forcing the wheel hub into the wheel bearing unit.

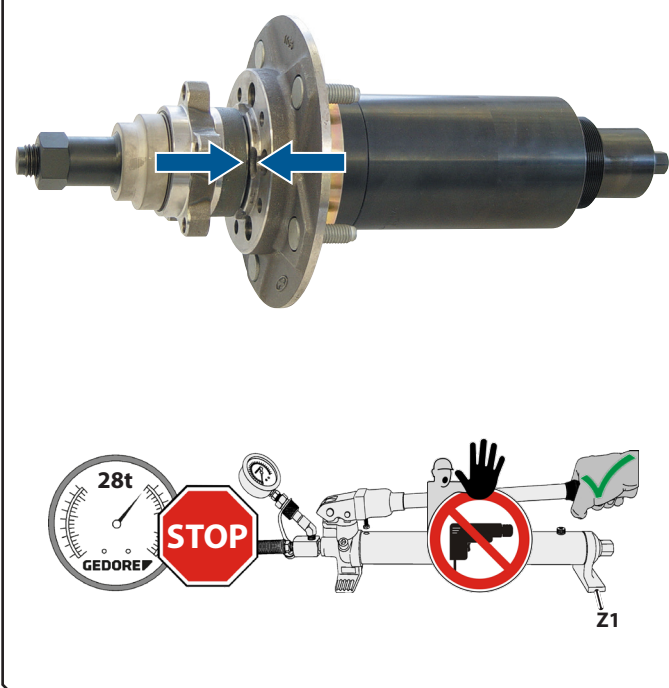

4.1.4 Forcing in the wheel hub

This typical application describes the **forcing the wheel hub in a new wheel bearing unit** on the front axle of vehicles with front and all-wheel drive. In connection with the wheel bearing tool set - **KL-0040-860**.

1) Mount the hydraulic cylinder [Z2] with all necessary components on the wheel bearing unit with wheel hub as shown in **📷 13A+B**.

ⓘ Ensure that the thrust disc [A3] is orientated in the correct position **📷 13B**.

⚠️ WARNING

There is the risk of the wheel bearing tool breaking when a machine-operated drive is used. Parts flying about can cause **DEATH** or **SEVERE INJURIES**.

► Use the wheel bearing tool exclusively with a manually operated **GEDORE Automotive** hydraulic cylinder/pump combination with a manometer for reliable pressure control!

2) Connect the hydraulic pump [Z1] with the hydraulic cylinder [Z2].

⚠️ CAUTION

There is a risk of the wheel bearing tool dropping when the wheel hub is forced in. This can cause **MEDIUM** or **LIGHT INJURIES!**

► Put down the wheel bearing tool **safely** to prevent it from dropping (for example on a workbench)!

⚠️ WARNING

When forcing in the wheel hub, there is a risk of the pull spindle breaking and parts being hurled about. This can cause **DEATH** or **SEVERE INJURIES**.

► **Never** exceed the **maximum load** of the wheel bearing tool of **28 tonnes!**

► **Constantly** watch the pressure on the pressure gauge of the hydraulic pump [Z1] while you are forcing in.

► **Never** stand in the axial extension of the pull spindle [Z3] while you are forcing in.

3) While you are operating the hydraulic pump [Z1], watch the pressure on the pressure gauge and force the wheel hub in the wheel bearing unit in accordance with the manufacturer's instructions. **📷 14**

ⓘ The maximum stroke of the hydraulic cylinder [Z2] is 50mm! As soon as this value is reached: Interrupt the forcing process, relieve the pressure at the hydraulic pump [Z1], re-tighten the clamping nut [Z4] until it is fully applied, and continue the forcing process.

4) Dismount the wheel bearing tool and carry out the further work on the vehicle in accordance with the manufacturer's instructions.

📷 15: Preparing hydr. cyl. [Z2].

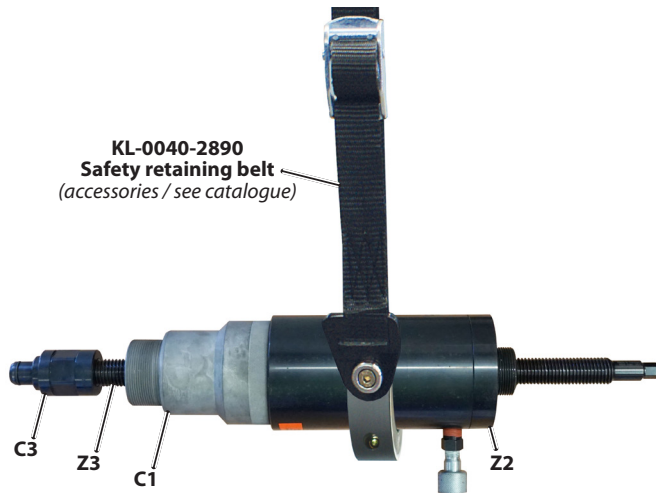

📷 16: Unscrewing the fastening screws.



📷 17: Screwing cheese-head screws [A4] into steering knuckles.

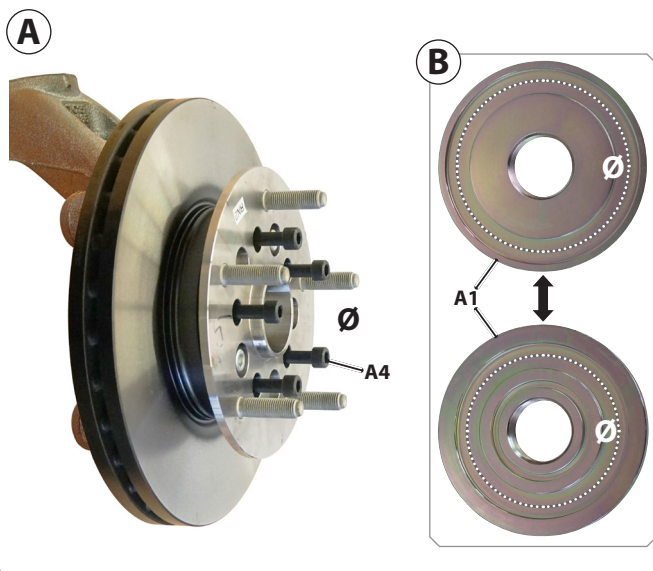

4.2 Removing the wheel hub bearing unit on the front axle with rear drive, using KL-0040-860 + KL-0040-862

Preparing the tool

1) Prepare the hydraulic cylinder [Z2] for the further work as shown in 📷 15.

ⓘ The safety retaining belt - KL-0040-2890, which is available as an accessory, or the mounting device - KL-0040-288 makes it possible to secure the wheel bearing tool against dropping.

4.2.1 Pulling off the wheel hub bearing unit with brake disc

This typical application describes the **pulling of the wheel hub bearing unit with brake disc off the steering knuckle** on the front axle of vehicles with rear drive. In connection with the wheel bearing tool set - KL-0040-860 + KL-0040-862.

ATTENTION

If the cheese-head screws [A4] are screwed in at different heights, there is a risk that the contact of the thrust ring [A1] is askew, which can damage the wheel bearing tool.

➤ **Ensure** that the cheese head screws are screwed to the same height [A4].

1) To start with, unscrew only the fastening screws of the wheel bearing unit. 📷 16

Next, screw the five cheese head screws [A4] at the same height as shown in 📷 17A into the mounting holes in the wheel bearing unit that became free.

ATTENTION

There is a risk of damaging the wheel bearing tool if the thrust ring [A1] is positioned with the wrong side on the cheese head screws [A4].

➤ The thrust ring [A1] has two application sides. Please bear in mind that the thrust ring [A1] must be aligned as required by the hole circle Ø of the cheese head screws [A4] that have already been screwed in.

2) First check which **groove** (front or back) on the thrust ring [A1] is needed 📷 17B. To do this, hold the thrust ring [A1] against the cheese head screws [A4] 📷 17A that have already been screwed in, and align it to match them.

📷 18: Assembling and positioning the wheel bearing tool.

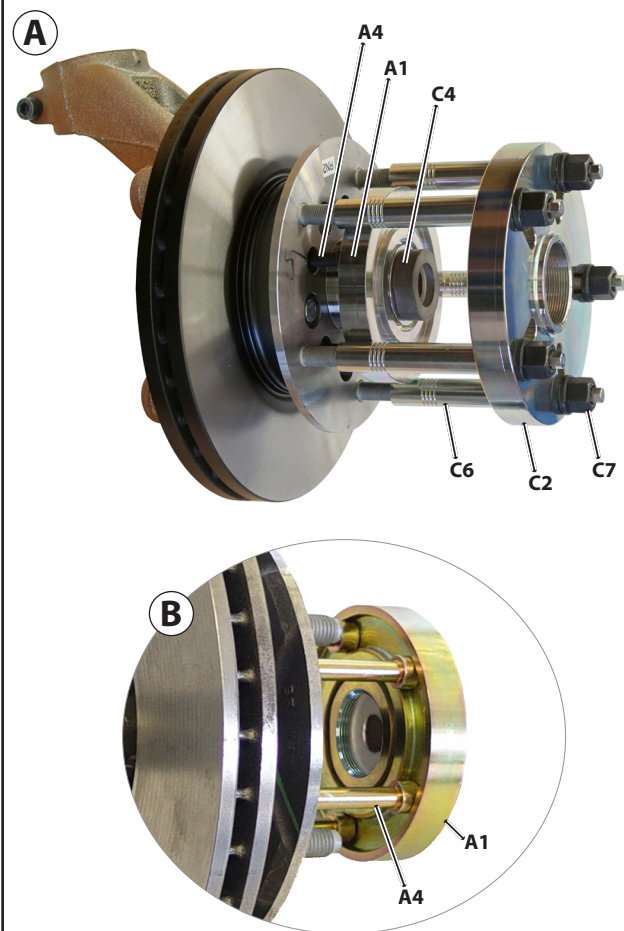

📷 19: Insert the prepared hydraulic cylinder [Z2], pull off the wheel hub bearing unit with brake disc.

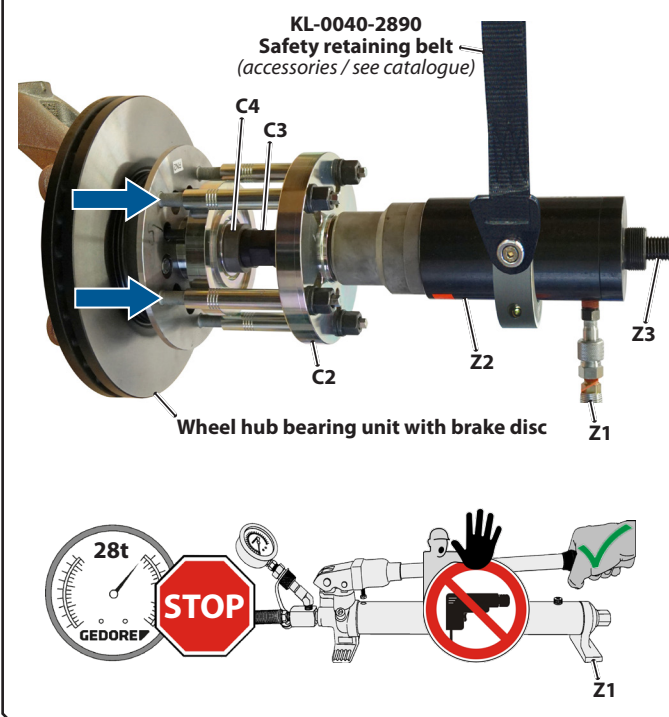

3) Mount all the necessary components of the wheel bearing tool, as shown in **📷 18A**, on the wheel hub bearing unit with brake disc.

① Ensure that the cheese-head screws [A4] are engaged completely and neatly in the groove at the thrust ring [A1] **📷 18B**.

4) Screw the prepared hydraulic cylinder [Z2] as shown in **📷 19** into the already mounted perforated disc [C2]. Next, screw the thrust spindle [Z3] into the hydraulic cylinder [Z2] until the thrust nut [C3] is in full contact with the pressure adapter [C4].

⚠️ WARNING

There is the risk of the wheel bearing tool breaking when a machine-operated drive is used. Parts flying about can cause **DEATH** or **SEVERE INJURIES**.

✔ Use the wheel bearing tool exclusively with a manually operated **GEDORE Automotive** hydraulic cylinder/pump combination with a manometer for reliable pressure control!

5) Connect the hydraulic pump [Z1] with the hydraulic cylinder [Z2].

⚠️ CAUTION

There is a risk of the wheel bearing tool dropping when the wheel hub bearing assembly is pulled off. This can cause **MEDIUM** or **LIGHT INJURIES**!

✔ As a **precaution**, secure the wheel bearing tool on the vehicle against dropping, for example using the safety retaining belt - **KL-0040-2890** or the mounting device - **KL-0040-288**!

⚠️ WARNING

During the removal of the wheel hub/bearing unit, there is a risk of the wheel bearing tool breaking and parts being hurled about. This can cause **DEATH** or **SEVERE INJURIES**.

✔ **Never** exceed the **maximum load** of the wheel bearing tool of **28 tonnes**!

✔ **Constantly** watch the pressure on the pressure gauge of the hydraulic pump [Z1] while you are pulling off.

✔ **Never** stand in the axial extension of the thrust spindle [Z3] while you are pulling off.

6) While you are operating the hydraulic pump [Z1], watch the pressure on the pressure gauge and pull the wheel hub bearing unit with brake disc off the steering knuckle. **📷 19**

① The maximum stroke of the hydraulic cylinder [Z2] is 50mm! As soon as this value is reached: Interrupt the forcing process, relieve the pressure at the hydraulic pump [Z1], re-tighten the clamping nut [Z4] until it is fully applied, and continue the forcing process.

7) Dismount the wheel bearing tool and continue with **Chapter 4.2.2 / Forcing off the brake disc**.

📷 20: Screwing cheese-head screws [C5] into brake disc.

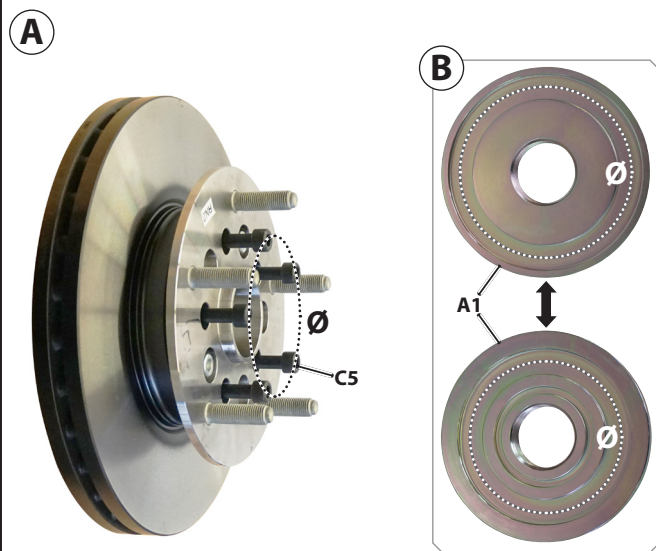

4.2.2 Forcing off the brake disc

This typical application describes the **forcing of the brake disc off the wheel hub bearing unit** on the front axle of vehicles with rear drive. In connection with the wheel bearing tool set - KL-0040-860 + KL-0040-862.

ATTENTION

If the cheese-head screws [C5] are screwed in at different heights, there is a risk that the contact of the thrust ring [A1] is askew, which can damage the wheel bearing tool.

➤ **Ensure** that the cheese head screws are screwed to the same height [C5].

1) To start with, unscrew the fastening screws of the brake disc. (See 📷 16)

Next, screw the five cheese head screws [C5] at the same height as shown in 📷 20A into the mounting holes in the brake disc that became free.

📷 21: Assembling and positioning the wheel bearing tool.

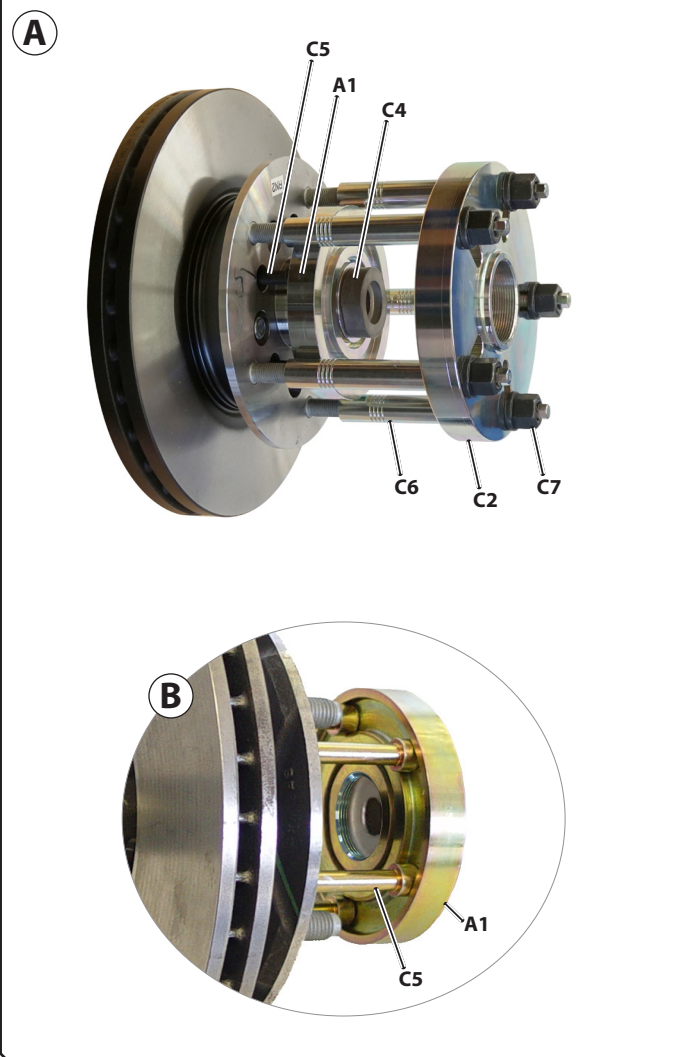

ATTENTION

There is a risk of damaging the wheel bearing tool if the thrust ring [A1] is positioned with the wrong side on the cheese head screws [C5].

➤ The thrust ring [A1] has two application sides. Please bear in mind that the thrust ring [A1] must be aligned as required by the hole circle Ø of the cheese head screws [C5] that have already been screwed in.

2) First check which **groove** (front or back) on the thrust ring [A1] is needed 📷 20B. To do this, hold the thrust ring [A1] against the cheese head screws [C5] 📷 20A that have already been screwed in, and align it to match them.

3) Mount all the necessary components of the wheel bearing tool, as shown in 📷 21A, on the wheel hub bearing unit with brake disc.

ⓘ Ensure that the cheese-head screws [C5] are engaged completely and neatly in the groove at the thrust ring [A1] 📷 21B.

📷 22: Insert the prepared hydraulic cylinder [Z2], force off the brake disc.

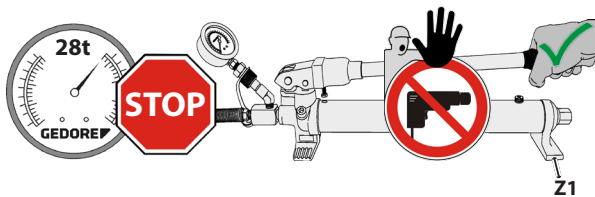
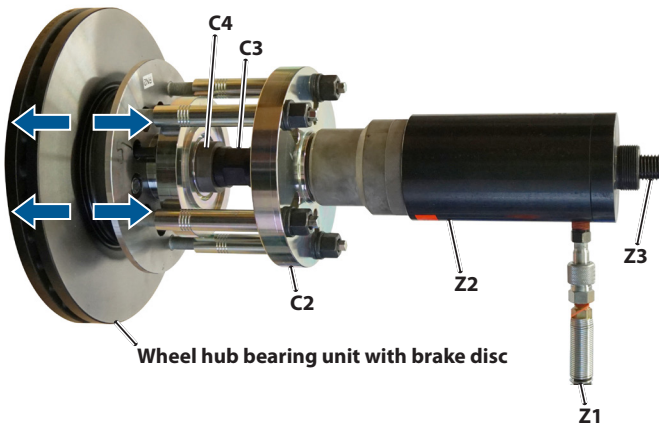

📷 23: Brake disc forced off.



4) Screw the prepared hydraulic cylinder [Z2] as shown in **📷 22** into the already mounted perforated disc [C2]. Next, screw the thrust spindle [Z3] into the hydraulic cylinder [Z2] until the thrust nut [C3] is in full contact with the pressure adapter [C4].

⚠️ WARNING

There is the risk of the wheel bearing tool breaking when a machine-operated drive is used. Parts flying about can cause **DEATH** or **SEVERE INJURIES**.

► Use the wheel bearing tool exclusively with a manually operated **GEDORE Automotive** hydraulic cylinder/pump combination with a manometer for reliable pressure control!

5) Connect the hydraulic pump [Z1] with the hydraulic cylinder [Z2].

⚠️ CAUTION

There is a risk of the wheel bearing tool dropping when the brake disc is forced off. This can cause **MEDIUM** or **LIGHT INJURIES!**

► Put down the wheel bearing tool **safely** to prevent it from dropping (for example on a workbench)!

⚠️ WARNING

When forcing off the brake disc, there is a risk of the brake disc breaking and parts being hurled about. This can cause **DEATH** or **SEVERE INJURIES**.

► **Never** exceed the **maximum load** of the wheel bearing tool of **28 tonnes!**

► **Constantly** watch the pressure on the pressure gauge of the hydraulic pump [Z1] while you are forcing off.

► **Never** stand in the axial extension of the thrust spindle [Z3] while you are forcing off.

6) While you are operating the hydraulic pump [Z1], watch the pressure on the pressure gauge and force the brake disc off the wheel hub bearing unit. **📷 22**

ⓘ The maximum stroke of the hydraulic cylinder [Z2] is 50mm! As soon as this value is reached: Interrupt the forcing process, relieve the pressure at the hydraulic pump [Z1], re-tighten the clamping nut [Z4] until it is fully applied, and continue the forcing process.

6) Dismount the wheel bearing tool and carry out the further work on the vehicle in accordance with the manufacturer's instructions.

📷 24: Screwing cheese-head screws [A4] into brake disc.

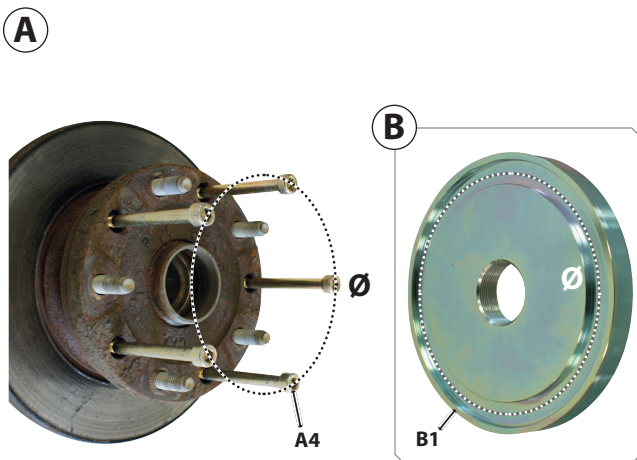

📷 25: Assembling and positioning the wheel bearing tool.

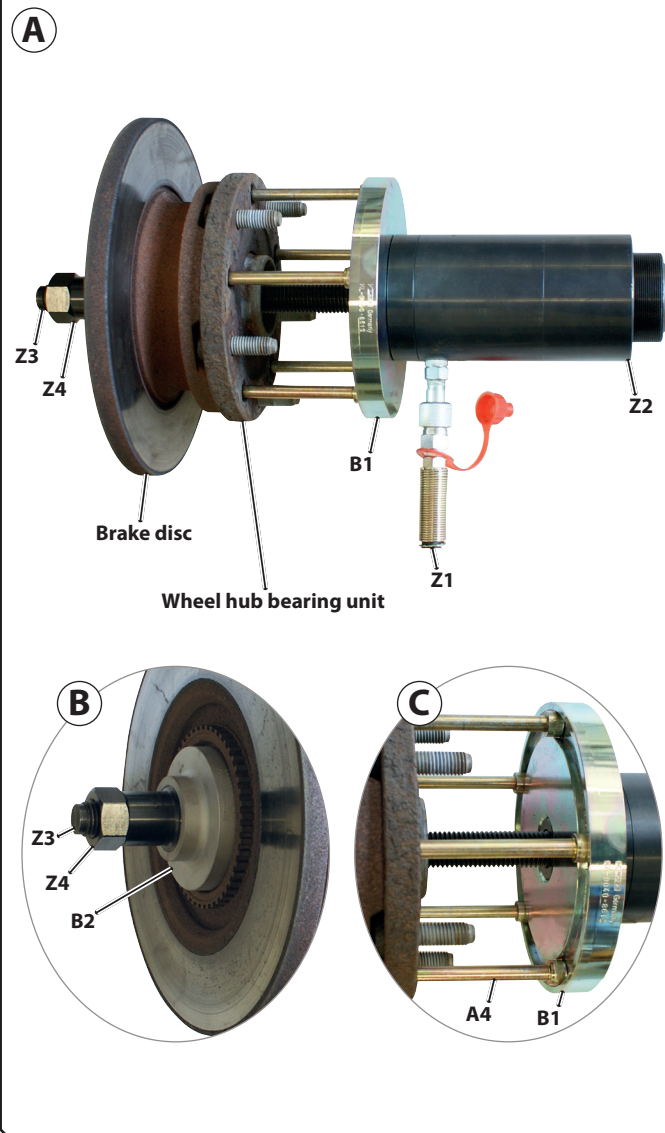

4.3 Forcing off the brake disc at the rear axle with front drive, using KL-0040-860 + KL-0040-861

This typical application describes the **forcing of the brake disc off the wheel hub bearing unit** on the rear axle of vehicles with front drive. In connection with the wheel bearing tool set - **KL-0040-860 + KL-0040-861**.

ATTENTION

If the cheese-head screws [A4] are screwed in at different heights, there is a risk that the contact of the thrust ring [B1] is askew, which can damage the wheel bearing tool.

► **Ensure** that the cheese head screws are screwed to the same height [A4].

1) To start with, unscrew the fastening screws of the brake disc.

Next, screw the five cheese head screws [A4] at the same height as shown in 📷 24A into the mounting holes in the brake disc that became free.

ATTENTION

There is a risk of damaging the wheel bearing tool if the thrust ring [B1] is positioned with the wrong side on the cheese head screws [A4].

► **Ensure** that the thrust ring [A1] is aligned with the groove in the direction of the already screwed in cheese-head screws [A4].

2) Mount the hydraulic cylinder [Z2] with all necessary components on the wheel bearing unit with brake disc as shown in 📷 25A+B.

ⓘ **Ensure** that the cheese-head screws [A4] are engaged completely and neatly in the groove at the thrust ring [B1] 📷 25C.

⚠️ WARNING

There is the risk of the wheel bearing tool breaking when a machine-operated drive is used. Parts flying about can cause **DEATH** or **SEVERE INJURIES**.

► Use the wheel bearing tool exclusively with a manually operated **GEDORE Automotive** hydraulic cylinder/pump combination with a manometer for reliable pressure control!

3) Connect the hydraulic pump [Z1] with the hydraulic cylinder [Z2].

26: Forcing the brake disc off the wheel hub bearing unit.

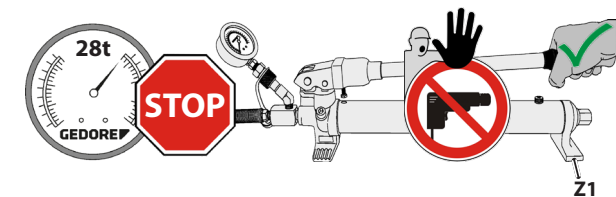
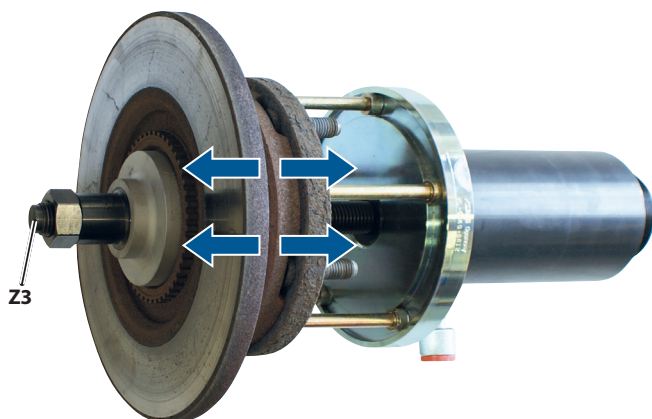

CAUTION

There is a risk of the wheel bearing tool dropping when the brake disc is forced off. This can cause **MEDIUM** or **LIGHT INJURIES!**

Put down the wheel bearing tool **safely** to prevent it from dropping (for example on a workbench)!

WARNING

When forcing off the brake disc, there is a risk of the pull spindle breaking and parts being hurled about. This can cause **DEATH** or **SEVERE INJURIES.**

Never exceed the **maximum load** of the wheel bearing tool of **28t!**

Constantly watch the pressure on the pressure gauge of the hydraulic pump [Z1] while you are forcing off.

Never stand in the axial extension of the pull spindle [Z3] while you are forcing off.

4) While you are operating the hydraulic pump [Z1], watch the pressure on the pressure gauge and force the brake disc off the wheel hub bearing unit. **26**

The maximum stroke of the hydraulic cylinder [Z2] is 50 mm! As soon as this value is reached: Interrupt the forcing process, relieve the pressure at the hydraulic pump [Z1], re-tighten the clamping nut [Z4] until it is fully applied, and continue the forcing process.

5) Dismount the wheel bearing tool and carry out the further work on the vehicle in accordance with the manufacturer's instructions.

5. CARE AND STORAGE

ATTENTION

Improper care and storage can damage the wheel bearing tool. Never use cleaning agents to clean the wheel bearing tool. This could destroy the device. After use, clean all parts only with a dry and clean cleaning cloth. Never immerse the wheel bearing tool in water, solvents or cleaning liquids. To protect them against corrosion, lightly rub all metal parts after use with an anti-corrosion oil or wax that is suitable for tool care. Store the wheel bearing tool and the operating instructions in the packaging at a dry and clean place.

6. REPAIR

WARNING

For safety reasons, ensure that a damaged wheel bearing tool is no longer used! Professional inspection and repair may only be carried out by specially trained specialist personnel at GEDORE Automotive GmbH. Improper repair can result in **DEATH** or **SEVERE INJURIES.**

7. ENVIRONMENTALLY COMPLIANT DISPOSAL

Dispose of the wheel bearing tool and the packaging material in an environmentally compatible way in accordance with the legal requirements. If necessary, ask your local authorities about environmentally friendly disposal options.

GEDORE-Werkzeugfabrik GmbH & Co. KG

Remscheider Straße 149
42899 - Remscheid
Postfach 120361
47873 Remscheid
GERMANY

Vertrieb DEUTSCHLAND

☎ +49 (0) 2191 / 596-0
☎ +49 (0) 2191 / 596-230
✉ info@gedore.com
🌐 www.gedore.com

Sales INTERNATIONAL

☎ +49 (0) 2191 / 596-910
☎ +49 (0) 2191 / 596-911
✉ info@gedore.com
🌐 www.gedore.com

GEDORE TOOLS, INC.

Only for USA, Canada & Mexico
Sólo para EE.UU., Canadá y México
Seulement pour les USA, le Canada et le Mexique
7187 Bryhawke Circle, Suite 700, North Charleston, SC 29418, USA

☎ +1-843 / 225 50 15
☎ +1-843 / 225 50 20
✉ info@gedoretools.com
🌐 www.gedoretools.com

Worldwide GEDORE service centers and offices are listed on the Internet at: www.gedore.com

GEDORE Automotive GmbH

Breslauer Straße 41
78166 - Donaueschingen
Postfach 1329
78154 Donaueschingen
GERMANY

Vertrieb DEUTSCHLAND

☎ +49 (0) 771 / 8 32 23-0
☎ +49 (0) 771 / 8 32 23-90
✉ info.gam@gedore.com
🌐 gedore-automotive.com



www.gedore-automotive.com