

GEDORE

TOOLS FOR LIFE

Ball Joint Extractor, Setra



KL-0165-37

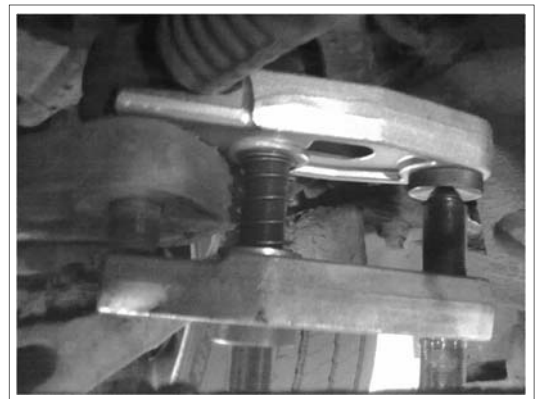

0165-37e170530.docx

GEDORE Automotive GmbH

Breslauer Straße 41
78166 Donaueschingen

Postfach 1329
78154 Donaueschingen - GERMANY

Phone.: +49 (0) 771 / 8 32 23-0
Fax: +49 (0) 771 / 8 32 23-90

Email: info@gedore-automotive.com
Internet: www.gedore-automotive.com

KL-0165-37



Components:

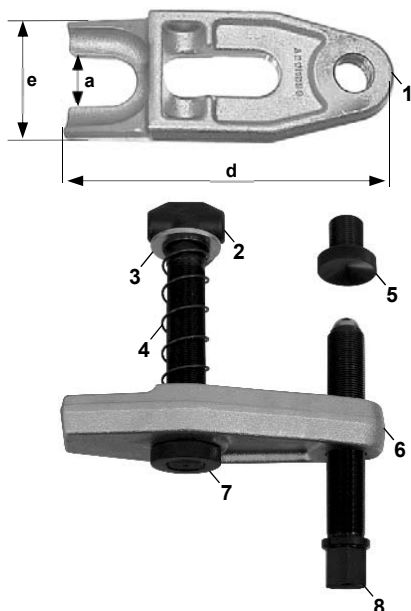

Example of use:



KL-0165-37 Ball Joint Extractor, Setra

Suitable for use on ball joints found at steering column control stalks on Mercedes-Benz/Setra buses such as MB Travego RHD L (O 580) and Setra S 417 UL.

Field of Application

The KL-0165-37 ball joint extractor is the ideal tool for separating ball joint connections in axle/suspension and steering systems.

Technical Data

Fork opening **a**: 33mm
 Fork length **d**: 200mm
 Fork width **e**: 80mm

Components:

Pos.	Part No.	Description	Qty
-	KL-0165-37	Ball Joint Extractor	1
<i>composed of:</i>			
1	KL-0165-3301	Fork, 42mm	1
2	KL-0165-3702	Adjusting Spindle, M24x1.5x129	1
3	KL-0165-3008	Plain Washer	2
4	KL-0165-3007	Spring	1
5	KL-0165-3005	Ball Socket	1
6	KL-0165-3701	Pressure Lever, Setra	1
7	KL-0165-3009	Knurled Nut, (short) M24x1.5	1
8	KL-0165-3014	Pressure Spindle, M24x1.5x135	1

Warnings and Notes

- Any work on vehicles should only be performed by qualified specialist personnel observing and complying with the directions, provisions, and safety regulations specified by the vehicle manufacturer!
- Always refer to the vehicle manufacturer's data and instructions as only these apply to all work that is carried out on the vehicle.
- All vehicle-specific data stated herein are supplied under reserve and without commitment.