

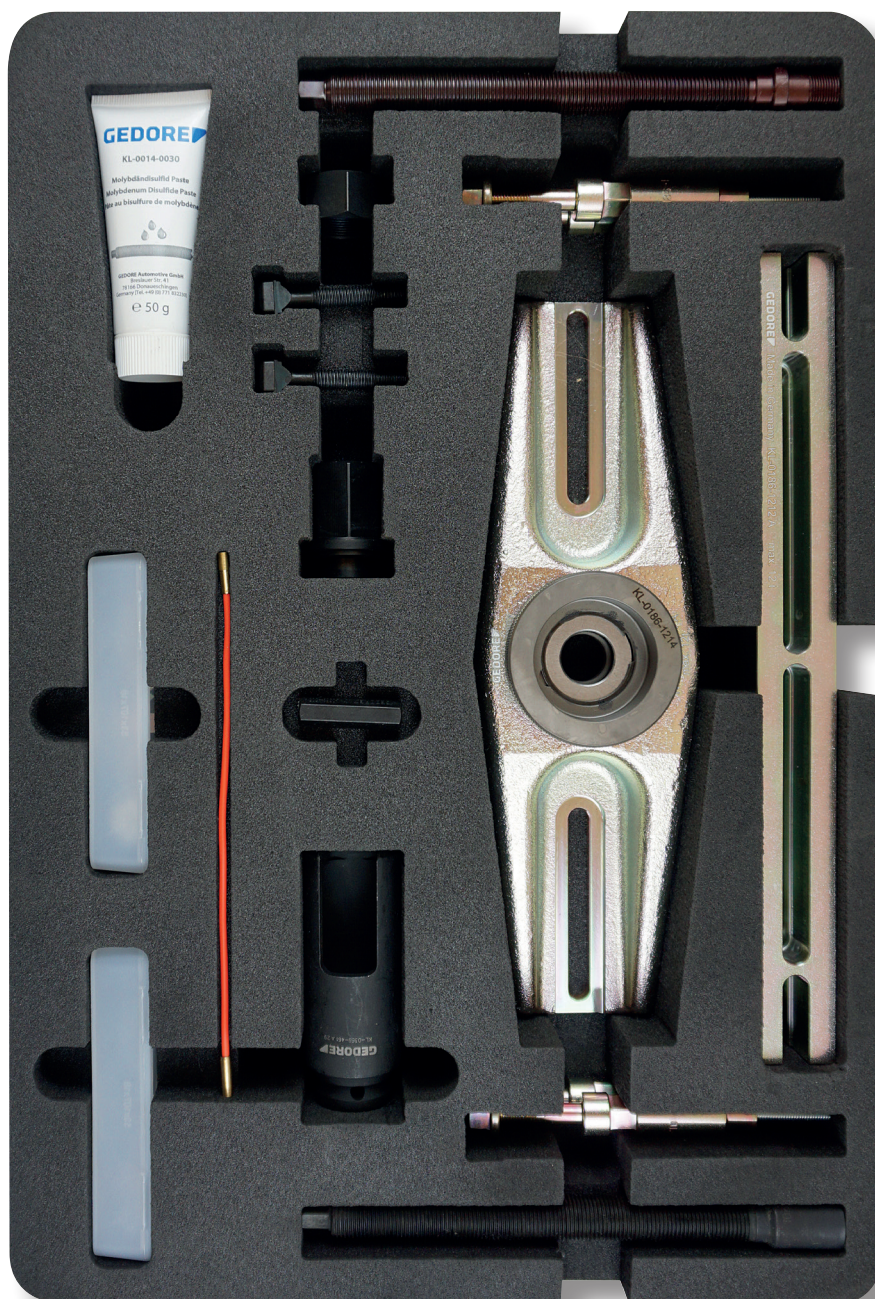

KL-0186-14 EA / KA /... Series Universal Injector Extractor Kit



Operating instructions EN
 ⚠ Read and understand before use!



www.gedore-automotive.com



GEDORE Automotive GmbH
 Breslauer Straße 41
 78166 - Donaueschingen
 Postfach 1329
 78154 Donaueschingen - GERMANY

☎ +49 (0) 771 / 8 32 23-0
 ☎ +49 (0) 771 / 8 32 23-90
 ✉ info.gam@gedore.com
 🌐 gedore-automotive.com

GEDORE TOOLS, INC.

Only for USA, Canada & Mexico / Sólo para EE.UU., Canadá y México
 Seulement pour les USA, le Canada et le Mexique
 7187 Bryhawke Circle, Suite 700
 North Charleston, SC 29418, USA

☎ +1-843 / 225 50 15
 ☎ +1-843 / 225 50 20
 ✉ info@gedoretools.com
 🌐 gedore.com

Version 2 - 04/2021

0186-14EA_Serie_EN210302.indd



ENGLISH

EN

Manufacturer's address

GEDORE Automotive GmbH

Breslauer Straße 41 // 78166 Donaueschingen - GERMANY

☎ +49 (0)771/83223-71 // ✉ info.gam@gedore.com

Imprint

In the course of improvement and adaptation to the state of the art, we reserve the right to make changes with regard to appearance, dimensions, weights and properties, and performance.

This does not imply any claim to correction or subsequent delivery of already delivered products. Deletions can be made at any time without any legal claim arising.

Instructions for use and safety are not binding. They never substitute for any legal or trade association regulations.

We do not accept any liability for printing errors.

Any reproduction, in whole or in part, requires the prior written consent of **GEDORE Automotive GmbH**.

All rights reserved worldwide. © Copyright by **GEDORE Automotive GmbH**, Donaueschingen (GERMANY)

We refer to our general terms and conditions which
can be found in the imprint at:

www.gedore-automotive.com



Contents

1. FOR YOUR SAFETY	4
1.1 Target group.....	4
1.2 Intended use	4
1.3 Reasonably foreseeable misuse	4
1.4 Personal protective equipment.....	4
1.5 Labelling of the warnings.....	5
1.6 Basic warnings	5
1.7 Basic safety instructions	6
1.8 Obligations of the owner.....	6
1.9 Work environment	7
1.10 Emissions.....	7
1.11 Maintenance	7
1.12 Troubleshooting.....	7
2. Product description (Modular system of injector extractor series ...)	8
2.1 KL-0186-14 EA / KA - Universal injector extractor kit.....	10
2.2 Scope of delivery/spare parts overview	10
2.3 Specifications.....	10
2.4 Overview of injector extractors.....	12
3. Preparation	13
3.1 Checking the scope of delivery	13
3.2 Required drive parts	13
3.3 Preparing the engine.....	13
4. Typical application	14
4.1 Preparing the injector	14
4.2 Installing the draw hook.....	16
4.3 Preparing the pull-off bridge.....	17
4.4 Removing the injector.....	19
5. Care and storage	19
6. Maintenance and repair	19
7. Support bolt/supplementary kit	20
8. Environmentally friendly disposal	23
9. Manufacturer's address	23

1. FOR YOUR SAFETY

Read and understand these operating instructions **before using** the injector extractor and observe all safety and warning instructions. Misuse can result in **DEATH** or **SEVERE INJURIES** !

These operating instructions are an integral part of the injector extractor. Keep them at a safe place for future reference, and always pass them on to subsequent users of the injector extractor.

The injector extractor complies with the recognised rules of technology as well as the relevant safety regulations.

1.1 Target group

These operating instructions are **exclusively** intended for skilled personnel in specialised motor vehicle workshops.

The injector extractor **may only be** used by skilled personnel in specialised motor vehicle workshops who are familiar with the basic regulations on work safety and accident prevention.

▼ **Never** allow unauthorised, inexperienced persons, minors and children, or persons with limited physical, sensory, and mental abilities to use the injector extractor.

1.2 Intended use

The injector extractor ...

▼ **may only** be used for the removal of injectors on diesel engines.

▼ **may only** be used to a **max. load of 12 tons**.

▼ **may only** be used with a manual drive with muscle power.

▼ **may only** be used with a muscle-powered and manually operated **GEDORE Automotive** hydraulic cylinder/pump combination with manometer for safe pressure control.

▼ **may only** be used in the way described in these operating instructions!

▲ Any other use can result in **DEATH** or **SEVERE INJURIES** !

1.3 Reasonably foreseeable misuse

The injector extractor ...

▼ **must never** be used without a securing device via the support pins!

▼ **must never** be used together with a machine-operated drive!

▼ **must never** be used together with a machine-operated hydraulic cylinder/pump combination!

▼ **must never** be modified, converted, or used for other purposes without authorisation!

▲ The injector extractor **may only** be used in the way described in **Chapter 1.2 - Intended use**! Any other use can result in **DEATH** or **SEVERE INJURIES** !

1.4 Personal protective equipment

For your safety, **always** wear personal protective equipment when using the injector extractor! The injector extractor can bring about mechanical hazards such as crushing, cutting and shock injuries.



Always wear **EYE PROTECTION** (see DIN EN 166, OSHA 29 CFR 1910.133, ANSI Z87) when using the injector extractor to protect yourself against flying parts or particles.

▼ When using the injector extractor, flying parts or particles can cause **SEVERE INJURIES** to your **eyes**!



Always wear **PROTECTIVE GLOVES** (see DIN EN 388, OSHA 29 CFR 1910.138, ANSI 105) when using the injector extractor to protect yourself against sharp edges and crushing between parts.

▼ When working with the injector extractor, sharp edges and crushing between parts can cause **SEVERE INJURIES** to your **hands**!







Always wear **SAFETY SHOES** (see DIN EN ISO 20345, OSHA 29 CFR 1910.136, ANSI Z41) when using the injector extractor to protect yourself against falling parts.

▼ When working with the injector extractor, falling parts can cause **SEVERE INJURIES** to your **feet and toes**!

1.5 Labelling of the warnings

Warnings are used to warn of possible **dangers**.

Always read and observe these warnings to avoid **DEATH** or **INJURIES!**

For better differentiation, warnings in these operating instructions are classified as follows:	
Warning sign	Meaning
 WARNING	Indicates a hazardous situation which, if not avoided, could cause DEATH or SEVERE INJURIES .
 CAUTION	Indicates a hazardous situation which, if not avoided, could cause MODERATE or MINOR INJURIES .
 ATTENTION	Indicates a situation which, if not avoided, can cause damage to the tool or an object in its vicinity.
	Note on important information and useful tips.

EN

1.6 Basic warnings

WARNING - Danger from MISUSE and OVERLOAD

The injector extractor can break if used incorrectly, thus flinging fragments and parts can lead to **DEATH** or **SERIOUS INJURIES!**

- ✔ Read and understand these operating instructions **before using** the injector extractor and **always observe all** safety and warning instructions when using it!
- ✔ **Only** use the injector extractor as described in these operating instructions.
- ✔ **Never** exceed the injector extractor's **maximum load** of **12 tonnes!**
- ✔ **Always** secure the injector extractor via the support pins on the engine!
- ✔ When using the hydraulic cylinder - **KL-0040-1700**, **additionally** secure it against being flung around by means of the safety retaining strap - **KL-0040-1790** on the engine!
- ✔ **Never** use the injector extractor with a machine-operated drive.
- ✔ **Only** use the injector extractor with a manually-operated drive with muscle power.
- ✔ **Never** use the injector extractor with a machine-operated hydraulic cylinder/pump combination!
- ✔ Use the injector extractor **exclusively** with a muscle-powered, manually operated **GEDORE Automotive** hydraulic cylinder / pump combination with a manometer for reliable pressure control!
- ✔ **Never** stand in axial extension of the injector extractor while it is subject to tension!
- ✔ **Never** use the injector extractor when it is damaged.
- ✔ **Never** beat the injector extractor with a hammer or anything similar.
- ✔ **Always** wear your personal protective equipment (safety goggles, protective gloves, safety shoes) when working.

CAUTION - Danger from FALLING

The injector extractor can fall down during preparation or use; falling parts can lead to **MODERATE** or **MINOR INJURIES** of the feet!

- ✔ **Always** deposit the injector extractor safely against falling down, for example on a clean workbench.
- ✔ **Always** wear your personal protective equipment (safety goggles, protective gloves, safety shoes) when working.

ATTENTION - Risk of DAMAGE

The engine and injector as well as the injector extractor may be damaged.

- ✔ **Always** observe vehicle-specific application procedures in the vehicle manufacturer's repair guide.
- ✔ **Always** support the injector extractor straight and even on the engine using the appropriate support pins!
- ✔ **Before each use**, lubricate the pulling spindle on the injector extractor with molybdenum disulphide paste (e.g. **KL-0014-0030**).

1.7 Basic safety instructions

For your own safety, **always** observe the following safety instructions and precautions when using the injector extractor in order to avoid injuries and material damage as a consequence of misuse and unsafe handling.

- ✔ Read and understand these operating instructions **before using** the injector extractor and observe all safety and warning instructions when using it.
- ✔ **Always** observe vehicle-specific application procedures in the vehicle manufacturer's repair guide.
- ✔ **Always** work on the vehicle in accordance with the basic regulations on work safety and accident prevention.
- ✔ In case of skin contact with hydraulic oil or molybdenum disulphide paste, clean the affected area **immediately** with fat-dissolving soap and water.
- ✔ **Never** use the injector extractor when you are tired or under the influence of alcohol, drugs, or medication!
- ✔ **Before each use**, check the injector extractor for damage and loose parts.
- ✔ **Never** use the injector extractor if it is damaged or has loose parts.
- ✔ Use **only genuine GEDORE Automotive** spare parts and accessories.
- ✔ While working with the injector extractor, make **absolutely** sure that **no** other persons are present in the direct working area.
- ✔ **Always** observe the **max. load** when using the injector extractor and **never** exceed it.
- ✔ **Always** keep hair, clothing, and gloves away from moving parts.
- ✔ **Never** use the injector extractor with a machine-operated drive.
- ✔ **Only** use the injector extractor with a manually-operated drive with muscle power.
- ✔ **Never** use the injector extractor with a machine-operated hydraulic cylinder/pump combination!
- ✔ Use the injector extractor **exclusively** with a muscle-powered, manually operated **GEDORE Automotive** hydraulic cylinder / pump combination with a manometer for reliable pressure control!
- ✔ **Always** wear your personal protective equipment (safety goggles, protective gloves, safety shoes) when working.
- ✔ Interrupt your work **immediately** if you are unsure about using the injector extractor, and contact **GEDORE Automotive GmbH if necessary!**

1.8 Obligations of the owner

The owner of the injector extractor **must** ensure that **only** trained personnel in specialised vehicle workshops use the injector extractor.

The owner of the injector extractor **must** ensure that the operating instructions are available to the user and that the user has completely read and understood the operating instructions **before** using the injector extractor.

The owner of the injector extractor **must** ensure that personal protective equipment is available to the user of the injector extractor.

The owner of the injector extractor **must** ensure that the user of the injector extractor is familiar with the basic regulations on work safety and accident prevention.

1.9 Work environment

For your safety, **only** use the injector extractor in a safe working environment.

- ▼ The workplace **must** be clean and tidy.
- ▼ The workplace **must** be sufficiently large and illuminated.
- ▼ The workplace **must** be located on a solid and non-skidding floor.
- ▼ The workplace **must** be safeguarded against access of unauthorised persons.
- ▼ The workplace **must** have a room temperature between -10°C and +40°C.

1.10 Emissions

Molybdenum disulphide paste and hydraulic oil can drip when using the injector extractor and thus pose a hazard to the environment.

- ▼ **Immediately** remove leaking hydraulic oil as well as excess molybdenum disulphide paste, e.g. with the aid of oil binding agents or a rag.
- ▼ Dispose of pollutants such as hydraulic oil and molybdenum disulphide paste in an **environmentally friendly** manner.
- ▼ Safety data sheets *as per (EC) Ordinance No. 1907/2006 about hydraulic oil (HLP 32)* and molybdenum disulphide paste (**MOLYKOTE(R) G-N PLUS PASTE**) can be found on the Internet (**World Wide Web**).

1.11 Maintenance

Always carry out maintenance work on the injector extractor when it is relaxed.

- ▼ **Before each use** of the injector extractor, check the draw spindle for dirt and damage; clean it if necessary and lubricate it **exclusively** with molybdenum disulphide paste. (e.g. **KL-0014-0030**)

1.12 Troubleshooting

Always perform troubleshooting on the injector extractor when it is depressurised/tension-free.

Problem: The draw spindle's clamping nut on the injector extractor is sluggish. (*Mechanical drive*)

Reason: The clamping nut and draw spindle are soiled or insufficiently lubricated; wrong lubricant used.

Remedy: Clean the clamping nut and draw spindle, check them for damage, and lubricate them **exclusively** with molybdenum disulphide paste. (e.g. **KL-0014-0030**)

Problem: Hydraulic oil escapes from the coupling between hydraulic cylinder and hand pump. (*Hydraulic drive*)

Reason: Hydraulic coupling soiled or loose.

Remedy: Clean and retighten the hydraulic coupling. Top up lacking hydraulic oil (**HLP 32**) at the hand pump.

2. Product description (Modular system of injector extractor series ...)

Injector extractor basic kit		Supplementary kits														
		KL-0186-14 EA	KL-0186-14 KA	KL-0186-130 A	KL-0186-132	KL-0186-1233	KL-0186-1234	KL-0186-1236	KL-0186-1238	KL-0186-1239	KL-0186-1240	KL-0186-1281	KL-0186-1282	KL-0186-1283	KL-0186-1284	KL-0186-1285
Basic tools and other parts:		Pos.														
KL-0186-121 A - Pulling bridge (basic tool)	A	●														
KL-0186-1215 - Collar nut M16x1.5	B	●														
KL-0186-122 - Support strip set	V															
KL-0369-4111 - Adapter (for impact extractor)	W															
KL-0126-221 - Magnetic lifter, flexible	X	●														
KL-0014-0030 - Molybdenum disulphide paste	Y	●														
Tool for opening the injector:																
KL-1383-1022 - Socket wrench size 25mm	C1											●				
KL-1383-1222 A - Socket wrench size 27mm	C2												●			
KL-0369-461 A - Socket wrench size 29mm	C3	●													●	
KL-0369-4505 A - Special insert size 10mm	C4	●														
KL-0186-2201 - Special insert 3 journals	C5														●	
KL-4417-17 A - Socket wrench size 17mm	C6												●			
Draw spindles:																
KL-0583-1032 - Draw spindle M14x1.5 / 200mm	D1	●														
KL-0583-1032 H - Draw spindle M14x1.5 / 315mm	D2															
KL-0186-1612 - Draw spindle M16x1 / 145mm	D3													●		
KL-0583-1005-1 - Draw spindle M17x1 / 200mm	D4	●														
KL-0583-1005-1 H - Draw spindle M17x1 / 315mm	D5															
KL-0186-1711 - Draw spindle M18x2.5 / 145mm	D6															●
KL-0186-1611-1 - Draw spindle M20x1 / 145mm	D7														●	
KL-0186-1611-1 H - Draw spindle M20x1 / 250mm	D8															
KL-1383-1021 - Draw spindle M25x1 / 132mm	D9											●				
KL-1383-1221 - Draw spindle M27x1 / 127mm	D10												●			
Union nuts for draw spindles:																
KL-0186-1611-2 - Union nut M25x0.5mm	E1														●	
KL-0186-1611-3 - Union nut M25x0.75mm	E2														●	
KL-0369-4606-2 - Union nut M27x1mm	E3	●														
Special nozzle extractor for DELPHI injector:																
KL-0369-420 - Nozzle extractor	F															●
Draw hook for strongly jammed BOSCH injectors:																
KL-0186-1321 - Draw hook	G1				●											
KL-0186-1322 - Knurled nut	G2				●											
KL-0186-1323 - Hexagon nut	G3				●											
Support pin:																
KL-0186-1231-11 - Support pin 110mm, M6	H1	● 4x														
KL-0186-1234-10 - Support pin 113.5mm, M6	H2					● 2x										
KL-0186-1236-20 - Support pin 129mm, M6	H3						● 4x	● 4x								
KL-0186-1233-11 - Support pin 145mm, M6	H4				● 4x											
KL-0186-1234-20 - Support pin 153.5mm, M6	H5					● 2x										
KL-0186-1240-10 - Support pin 170mm, M6	H6											● 4x				
KL-0186-1239-10 - Support pin 128.5mm, M7	H7									● 4x						
KL-0186-1232-1 - Support pin 120mm, M8	H8		● 4x													
KL-0186-1232-1 L - Support pin 175mm, M8	H9			● 4x												
Grub screws:																
KL-0186-1235-2 - Grub screw M6 x 25mm	i1	● 4x			● 4x	● 4x		● 4x		● 4x						
KL-0186-1235-3 - Grub screw M6 x 45mm	i2	● 4x														
KL-0186-1235-4 - Grub screw M6 x 65mm	i3						● 4x									
KL-0186-1235-6 - Grub screw M7 x 55mm	i4									● 4x						
Spacer nuts:																
KL-0186-1251-1 - Spacer nut M6 x 5mm	J1	● 4x					● 4x									
KL-0186-1252-1 - Spacer nut M6 x 10mm	J2	● 4x														
KL-0186-1253-1 - Spacer nut M6 x 15mm	J3	● 4x														
KL-0186-1261-1 - Spacer nut M8 x 10mm	J4		● 4x													



EN

i This overview shows the entire modular system. The individual components can be individually assembled according to the engine and injector.

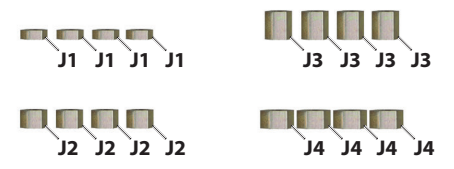
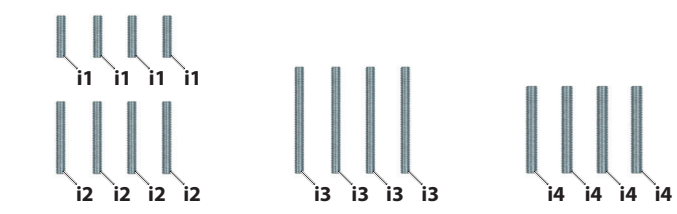
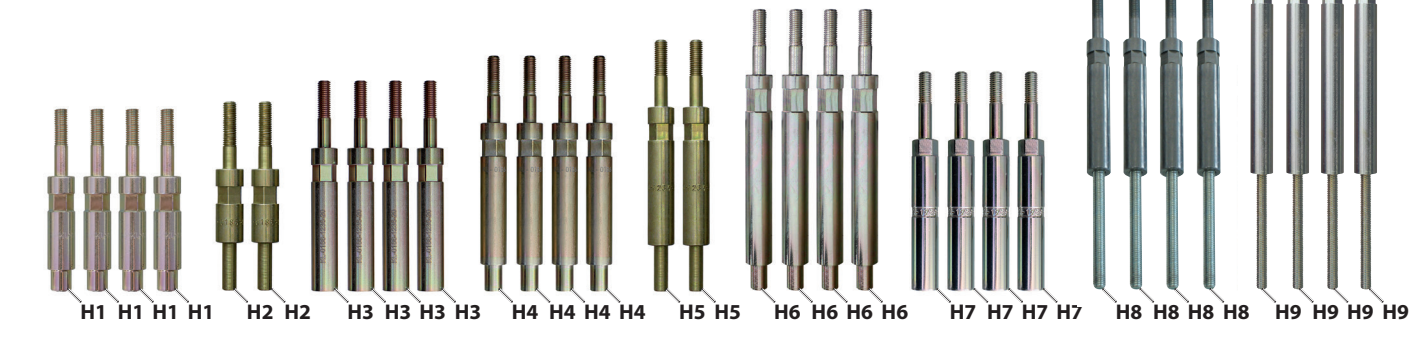
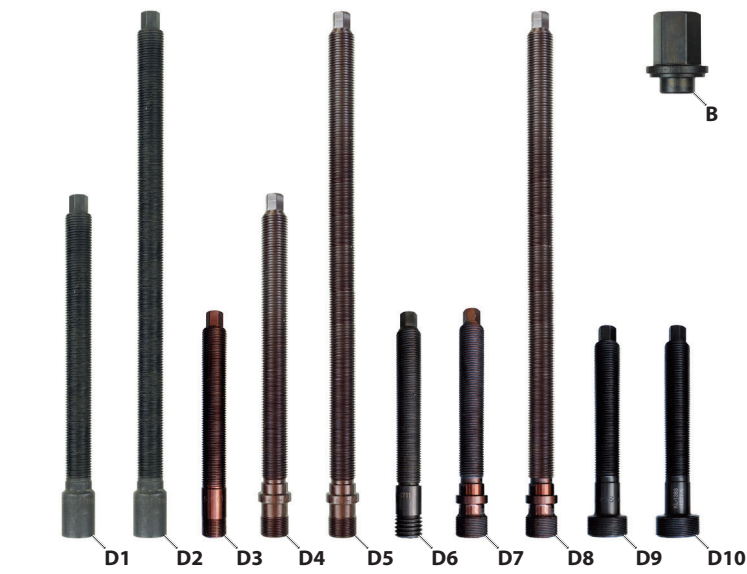
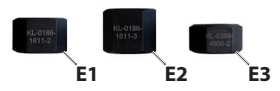
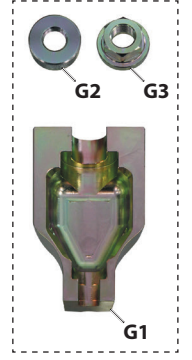

2.1 KL-0186-14 EA / KA - Universal injector extractor kit

Universally suitable for diesel engines, especially for BOSCH injectors with M14x1.5 external thread as well as M17x1 internal thread, and also for DELPHI injectors with M14x1.5 external thread.

Particularly suitable for Mercedes, for example: OM611, OM612, OM613, OM628**, OM629**, OM639, OM640, OM642**, OM646, OM646 EVO, OM647, OM648 (**V-engines: engine removal may be necessary for space reasons); Peugeot, Citroën, Fiat, Lancia, Suzuki: DV6 16V (not on Euro 5 [8V] engines); Ford: 1.6 TDCi (G8DA, G8DB, HHDA, HHJA, HHJB); VW-Audi: 2.0, 2.5, 2.7, 3.0 Common Rail TDI; Volvo: 1.6 D (D4164T), 2.2 D; Mazda: Y6 DV6 16V (not on Euro 5 [8V] engines)

The injector extractor kit enables fast and professional removal of severely stuck injectors directly on the vehicle without removing the cylinder head. For this purpose, screw the 4 support pins with M6x1 mounting thread into the valve cover mounting holes on the cylinder head and place the special pull-off bridge over them afterwards. The spacer nuts included in the scope of delivery enable height compensation of the support pins. By using the appropriate draw spindle, the stuck injector can now be taken out.

① The injector extractor can also be used for many other common rail diesel engines by using the optionally available support pins, draw spindles and supplementary kits. (👁️ Chapter 7. Support pins/Supplementary kits.

2.2 Scope of delivery / Overview of the single parts

Pos.	Part no.	Description	Qty.
A	KL-0186-121 A	Pull-off bridge (basic tool)	1
A1	KL-0186-1211	Base plate	1
A2	KL-0186-1212 A	Support strip	2
A3	KL-0206-1011	Collar nut M8	6
A4	KL-0186-1213	Screw for T-groove M8	2
A5	KL-0186-1214	Adapter with axial bearing	1
A5.1	KL-0186-1214-1	Adapter without axial bearing	1
A5.2	KL-0021-0006	Axial bearing	1
A5.3	KL-0040-3005	Circlip	1
B	KL-0186-1215	Collar nut M16x1.5	1
C3	KL-0369-461 A	Socket wrench size 29mm	1
C4	KL-0369-4505 A	Special insert size 10mm	1
D1	KL-0583-1032	Draw spindle M14x1.5 / 200mm	1
D4	KL-0583-1005-1	Draw spindle M17x1 / 200mm	1
E3	KL-0369-4606-2	Union nut M27x1mm	1
H1	KL-0186-1231-11	Support pin 110mm, M6	4
i1	KL-0186-1235-2	Grub screw M6 x 25mm	4
i2	KL-0186-1235-3	Grub screw M6 x 45mm	4
J1	KL-0186-1251-1	Spacer nut M6 x 5mm	4
J2	KL-0186-1252-1	Spacer nut M6 x 10mm	4
J3	KL-0186-1253-1	Spacer nut M6 x 15mm	4
X	KL-0126-221	Magnetic lifter, flexible	1
Y	KL-0014-0030	Molybdenum disulphide paste	1
-	KL-0186-14/80	Laminated insert	1
-	KL-4990-2001	Plastic box 53 x 107 x 18	2
-	KL-0186-1492 A	Foam insert	1

① KL-0186-14 KA is additionally in plastic case - KL-4990-9474

2.3 Specifications

Mounting thread of the draw spindle [F1]:M14x1.5mm

Mounting thread of the draw spindle [F2]: M17x1mm

Mounting thread of the union nut [G1]: M27x1mm

Max. load: 12t

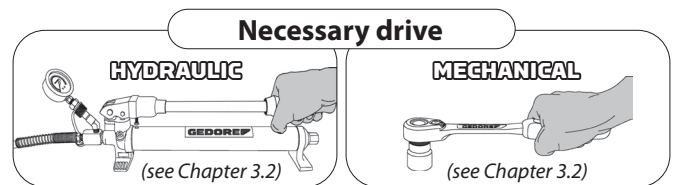

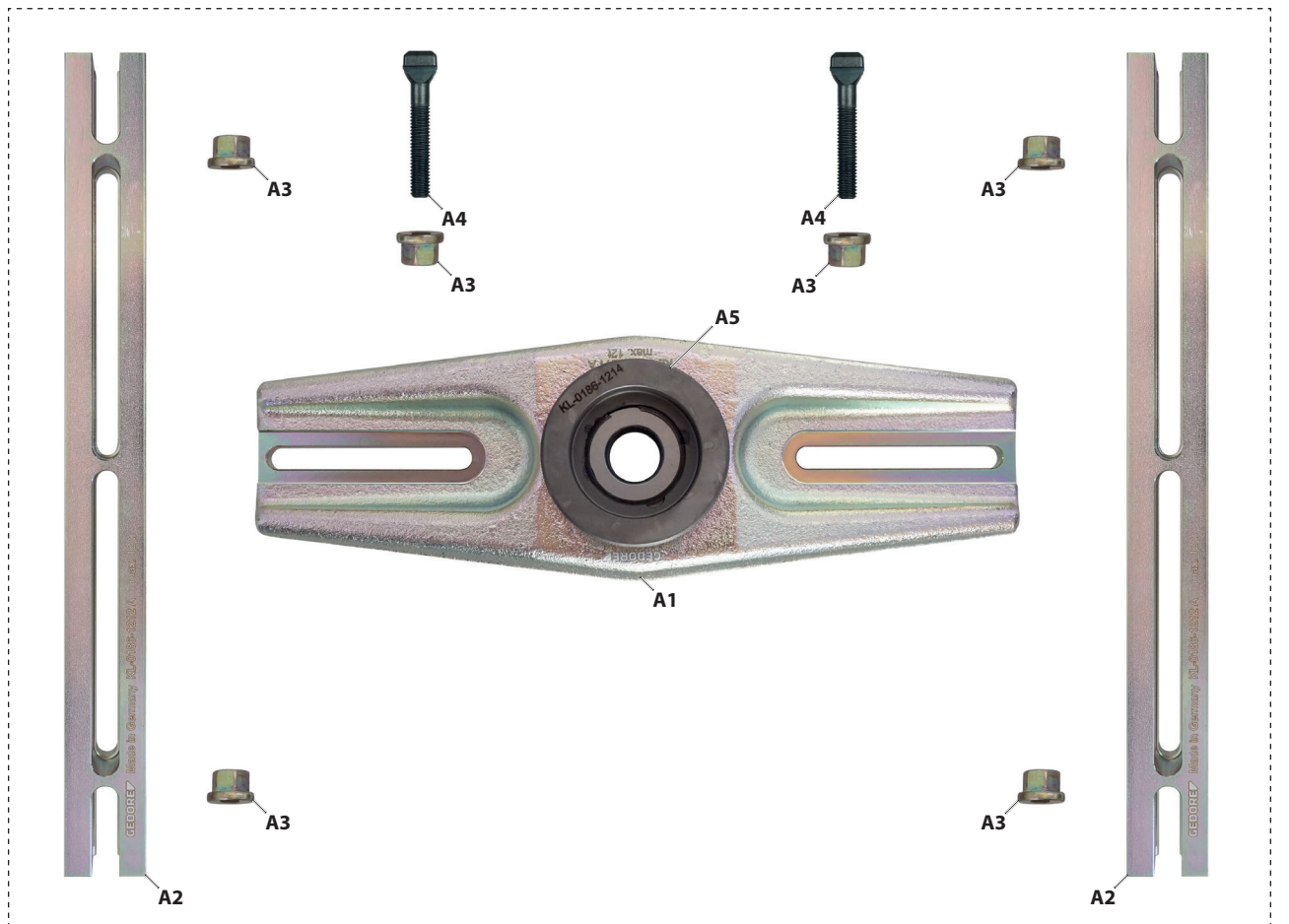

A

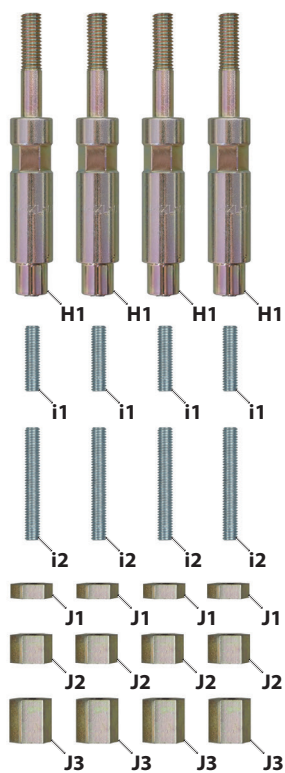

2.4 Overview of injector extractors



This overview shows an example with the basic components when using the injector extractor. The individual components can be individually assembled according to the engine and injector.

Draw spindle

Screwed in or on the injector, to pull out the injector by turning the collar nut.

Basic tool

To take up the draw spindle and when distributing the load when extracting the injector.

Support pins

Adjusted accordingly in length and screwed into the cylinder head to take up the load when removing the injector.

Injector

Depending on the design, it must be prepared accordingly for removal.

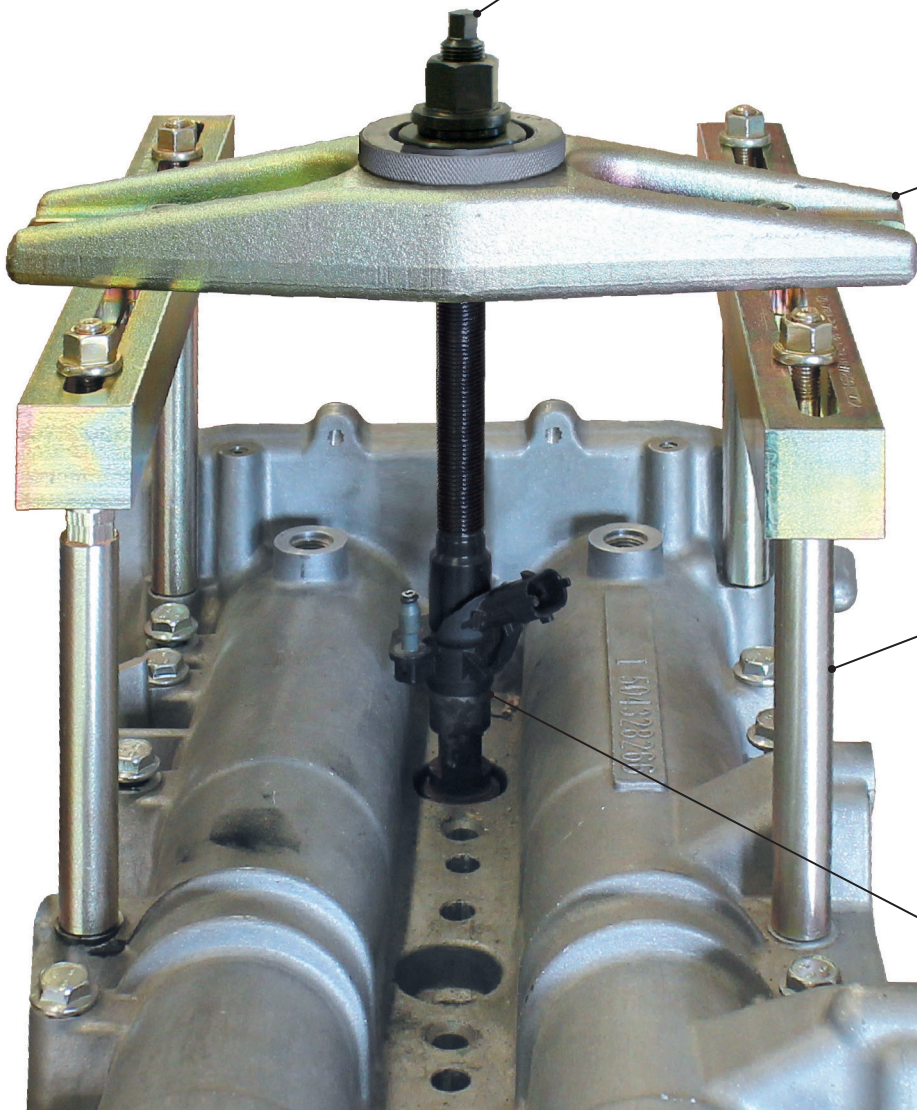

📷1: Required drive parts

Hydraulic driving parts:



Z1 (KL-0215-35 M25 - Hydraulic pump with 17t manometer)

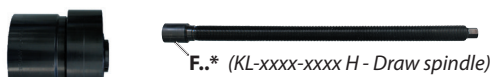

F.* (KL-xxxx-xxxx H - Draw spindle)

Z2 (KL-0040-1700 - Hydraulic cylinder 17t, short)



Z3 (KL-0040-1790 - Safety harness)

* Use long draw spindle with end **H**. (KL-xxxx-xxxx H)

Mechanical driving parts:



Z4 (e.g. 7 R 24 - Open-ended spanner with ring ratchet 24 mm)



Z5 (e.g. 7 R 10 - Open-ended spanner with ring ratchet 10 mm)

📷2: Preparing in accordance with the manufacturer's specifications.

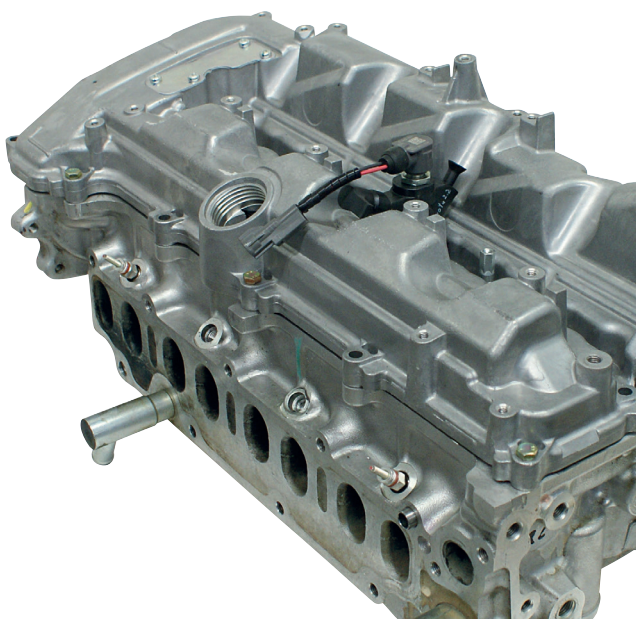

3. Preparation

⚠️WARNING

The injector extractor may break during use, and ejected parts may lead to **DEATH** or **SERIOUS INJURIES!**

▼ Carefully check the injector extractor for damage **before each use**.

▼ Never use the injector extractor when it is damaged.

▼ Use **only genuine GEDORE Automotive spare parts and accessories**.

3.1 Checking the scope of delivery

Prior to using the injector extractor, check that all parts of the scope of delivery are available. Follow the instructions below.

3.2 Required drive parts

⚠️WARNING

The injector extractor may break if a machine-operated drive is used; ejected parts may lead to **DEATH** or **SERIOUS INJURIES!**

▼ Use the injector extractor **exclusively** with a muscle-powered, manually operated drive, or a muscle-powered, manually operated **GEDORE Automotive** hydraulic cylinder / pump combination with a manometer for reliable pressure control!

Assemble the required drive parts either **hydraulically** or **mechanically** as shown in 📷1.

📌 Drive parts, see GEDORE-Automotive main catalogue.

3.3 Preparing the engine

1. Prepare injector for removal according to manufacturer's instructions. Dismantle the high-pressure line on the injector, remove the fastening of the injector, and disconnect the cable connector 📷2.

📷3: Depending on the injector, use the following tools for opening and disassembly.

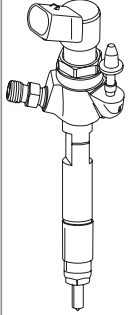
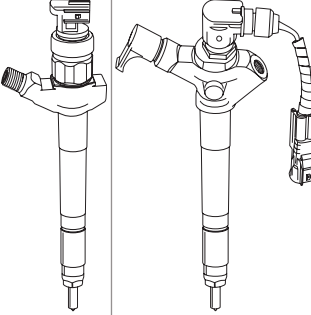
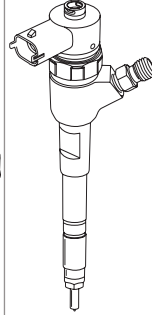
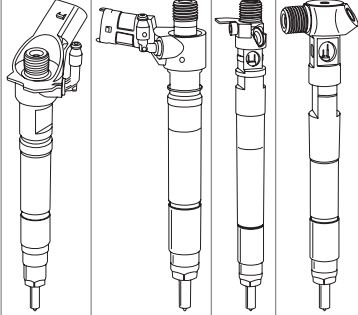
Manufacturer:	Siemens	Denso	Bosch	Delphi
Injector:				
Open injector with ..	Pos.			
KL-1383-1022 - Socket wrench size 25mm	C1	●*		
KL-1383-1222 A - Socket wrench size 27mm	C2	●*	●	
KL-0369-461 A - Socket wrench size 29mm	C3		●	
KL-4417-17 A - Socket wrench size 17mm	C6		●	
Disassemble injector with ...	Pos.			
KL-0369-4505 A - Special insert size 10mm	C4		●	
KL-0186-2201 - Special insert 3 journals	C5	●*		
Open-ended spanner size 22mm	-	●*		

Opening and disassembling not necessary!

** Optionally depending on the wrench size of the injector.*

📷4: Loosen and remove the locking nut on the injector.

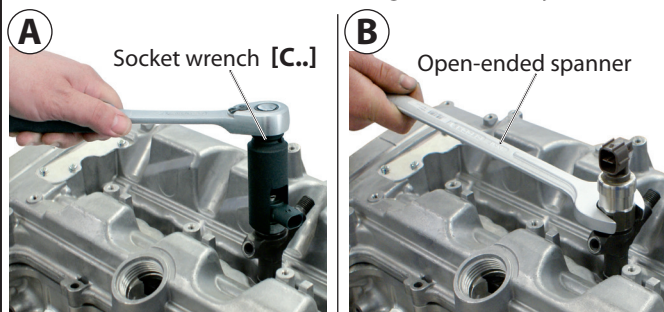

📷5: Loosen the screw ring on the injector and remove it.

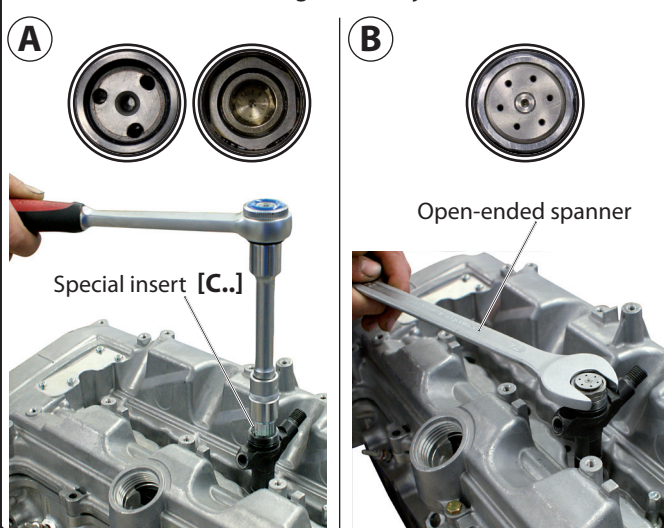

4. Typical application

📷 This typical application describes the removal of a jammed injector on the cylinder head. In general, the removal in both the **mechanical** or **hydraulic** way follows the same principle.

4.1 Preparing the injector

- Depending on the injector, it may be necessary to open and dismantle the injector with the aid of a suitable tool (see 📷 3) in order to screw in a feed screw.
 - An opened injector must be returned to the manufacturer and checked for reuse.

- Loosen and remove the lock nut on the injector as shown in 📷 4A or B, using a suitable socket wrench [C..] or open-ended spanner.

📷 It may be necessary to turn the cable connection on the injector slightly so that the socket wrench [C.] fits onto the lock nut!

- Loosen and remove the screw ring on the injector as shown in 📷 5A or B using a suitable special insert [C..] or open-ended spanner. Then remove all loose internal parts with the magnetic lifter [X].

📷6: Depending on injector, use the following traction spindle.

Manufacturer:			Siemens	Denso	Bosch	Delphi	
Injector:							
Thread:	Draw spindle:	Pos.	📷7A		📷7B		📷7C
M14x1.5	KL-0583-1032	D1			● ^M	● ^M	● ^M
	KL-0583-1032 H	D2			● ^H	● ^H	● ^H
	+ additionally KL-0186-132*	G1-3			● [*]	● [*]	
M16x1	KL-0186-1612	D3		● ^M			
M17x1	KL-0583-1005-1	D4			● ^M		
	KL-0583-1005-1 H	D5			● ^H		
M18x2.5	KL-0186-1711	D6					● ^M
	+ additionally KL-0369-420	F					●
M20x1	KL-0186-1611-1	D7		● ^M			
	KL-0186-1611-1 H	D8		● ^H			
M25x1	KL-1383-1021	D9	● ^M				
M27x1	KL-1383-1221	D10	● ^M				
Thread:	Union nut:	Pos.	📷7A		📷7B		📷7C
M25x0.5	KL-0186-1611-2	E1		● ^{**}			
M25x0.75	KL-0186-1611-3	E2		● ^{**}			
M27x1	KL-0369-4606-2	E3			●		

^M For mechanical drive / ^H For hydraulic drive / ^{*} Required only for extremely tight-fitting injectors / ^{**} Depending on thread on injector

📷7: Mount the draw spindle on the injector.

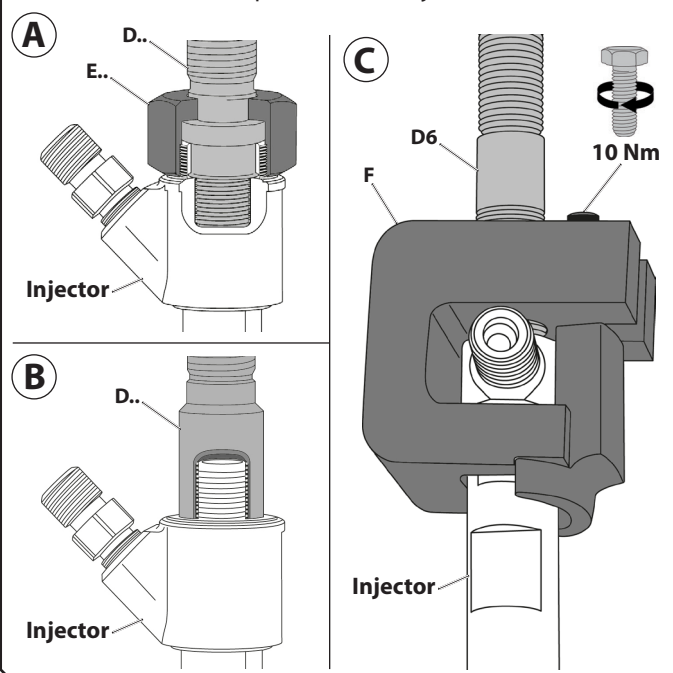

2. Depending on the mounting thread on the injector, determine a suitable draw spindle or nozzle extractor (see **📷6**).

① Draw spindles for the hydraulic drive are longer and marked with the suffix **H** or **HA** (KL-xxxx-xxx **H**)!

3. Fully insert the appropriate draw spindle [D..] at the injector **📷7A**, or screw it on **📷7B**.

For injectors with side fuel connection (90° angle), mount the nozzle extractor [F] on the injector in conjunction with the draw spindle [D6] as shown in **📷7C**.

4. Depending on the injector and draw spindle, also mount an appropriate union nut [E..], if necessary **📷7A**.

① By screwing on a union nut, the force is distributed evenly and stably to both threads when pulling out extremely tight-fitting injectors.

5. If the draw hook [G1] is used, continue with **chapter 4.2**, otherwise continue with **chapter 4.3**

📸8: Screw on the hexagon nut and knurled nut [G2+3].

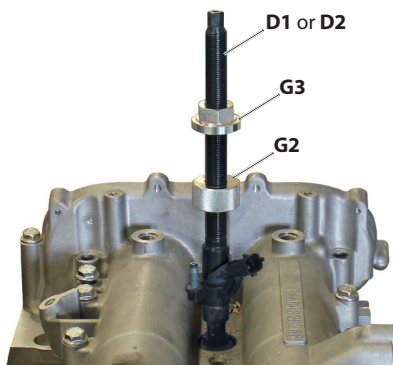

📸9: Insert the draw hook [G1] on the injector.

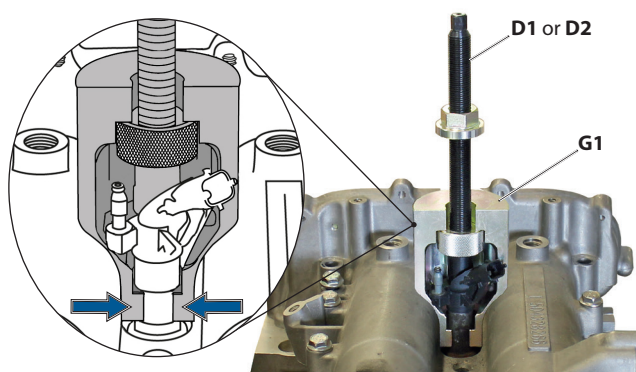

📸10: Pretension the draw hook [G1] with the knurled nut [G2].

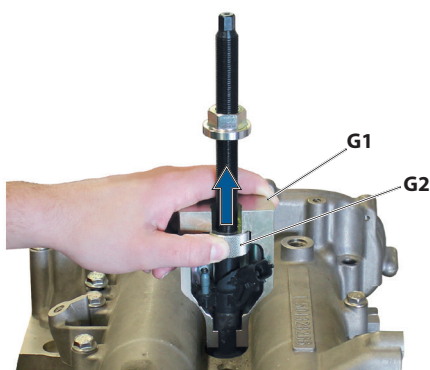

📸11: Fix the draw hook [G1] with the hexagon nut [G3].

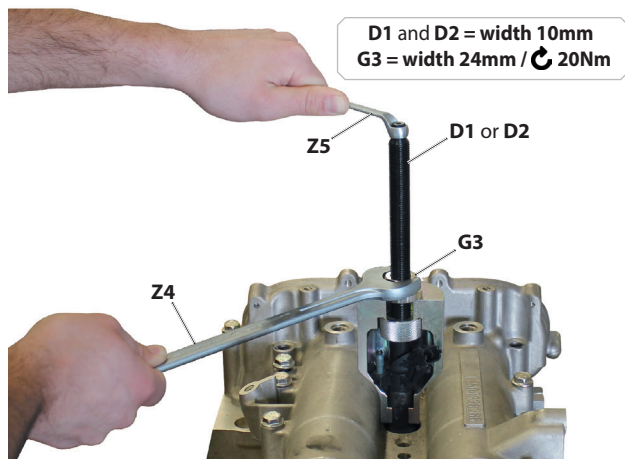

4.2 Installing the draw hook

- ❗ This step is **only** necessary **when using** the draw hook [G1], otherwise continue with **chapter 4.3**.
- ❗ The additional use of the draw hook distributes the force evenly and stably to both the draw spindle and the draw hook when removing extremely tight-fitting injectors.

1. Screw the knurled nut [G2] and the hexagon nut [G3] onto the feed shaft [D1 or D2] as shown in **📸8**.

CAUTION

The draw hook [G1] and the injector may be damaged.

▼ Fully insert the draw hook [G1] on the injector.

2. Insert the draw hook [G1] as shown in **📸9** on the injector and the draw spindle [D1 or D2].

CAUTION

The draw hook [G1] and the injector may be damaged.

▼ Use the knurled nut [G2] and pretension the draw hook [G1] completely in the direction of pull (UPWARDS).

3. Pretension the draw hook [G1] in the direction of pull (UPWARDS) as shown in **📸10** using the knurled nut [G2].

CAUTION

The injector may be damaged when tightening the hexagon nut [G3].

▼ Counterhold the feed screw [D1 or D2] against the hexagon nut [G3] when tightening it.

4. Fix the draw hook [G1] by tightening the hexagon nut [G3] as shown in **📸11**.

5. The draw hook [G1] is no longer shown below, but the rest of the process basically follows the same principle.

📷 12: Assemble support pin [H..].

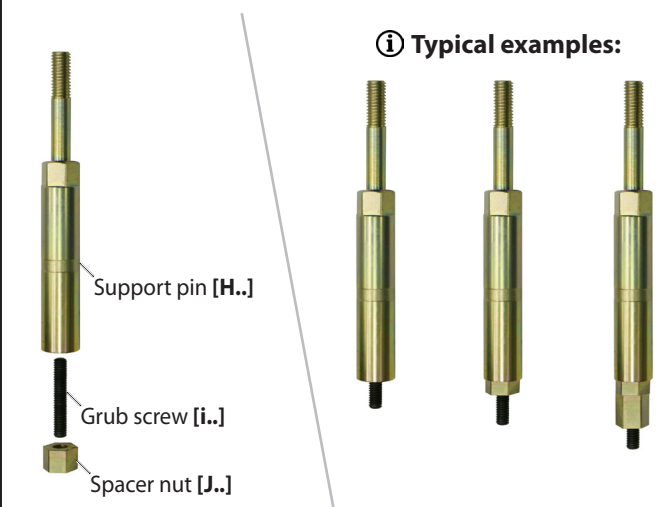

📷 13: Screw in support bolt pin [H..].

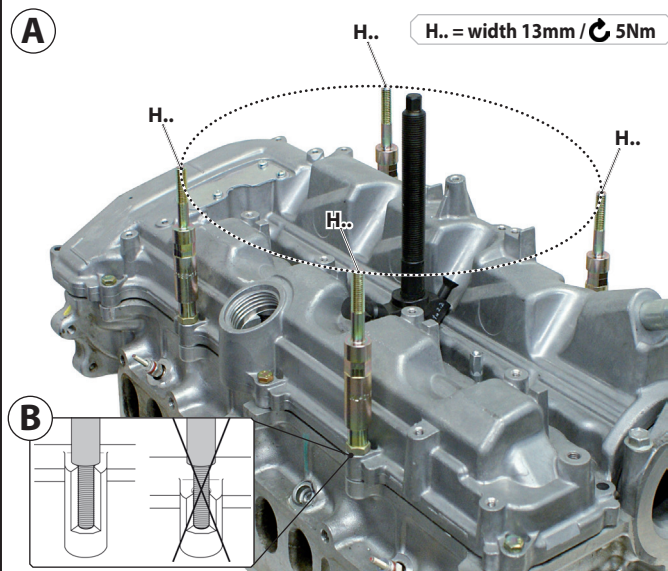

📷 14: Fit and secure the support strips [A2].

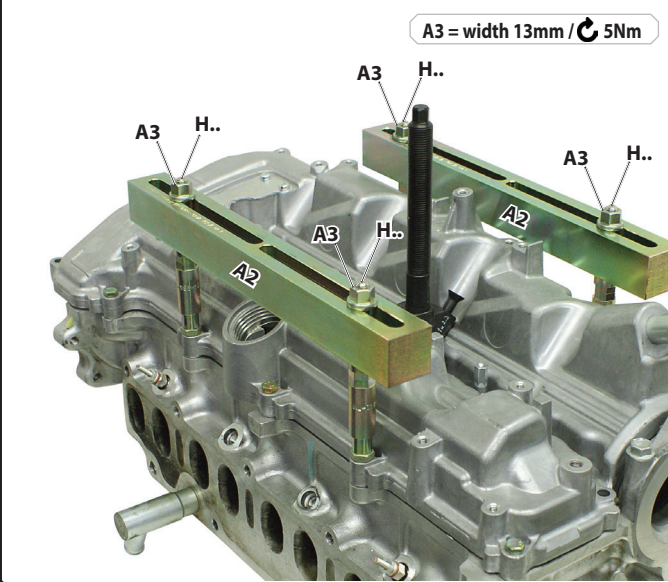

4.3 Preparing the pull-off bridge

CAUTION

The cylinder head and the injector extractor may be damaged.
 ▼ Select support holes which are lying evenly around the injector and seated stably in the solid material of the cylinder head.

1. To pull out the injector, screw in 4 support pins to take up the load on the cylinder head 📷 13.

To do this, unscrew 4 valve cover screws evenly around the injector on the cylinder head.

- i** If no support is possible on the holes for the valve cover bolts, but the cylinder head has smooth and stable contact surfaces, for example after removing the valve cover, you can use the support strips [V] as an alternative for screwing in the support pins.

CAUTION

The cylinder head and the injector extractor may be damaged.
 ▼ Arrange the length of the support pins on the cylinder head in such a way that they are all exactly at the same height after inserting! This is prerequisite for straight removal of the injector!

▼ Be sure to insert the support pins completely into the cylinder head 📷 13B!

2. Depending on thread diameter of the valve cover screws and the height required to remove the injector, assemble the support pins [H..], grub screws [i..], and any spacer nuts [J..] required for height compensation 📷 12.

Subsequently insert the 4 support pins [H..] into the cylinder head as shown in 📷 13A uniformly around the injector and tighten them with **5 Nm**.

- i** The length of the support pins can also be adjusted using the different grub screws [i..] and spacer nuts [J..] 📷 12.

3. Mount the support strips [A2] on the support bolts [H..] as shown in 📷 14 and secure them with the collar nuts [A3] fastened with **5 Nm**.

📷 15: Fit and secure the base plate [A1].

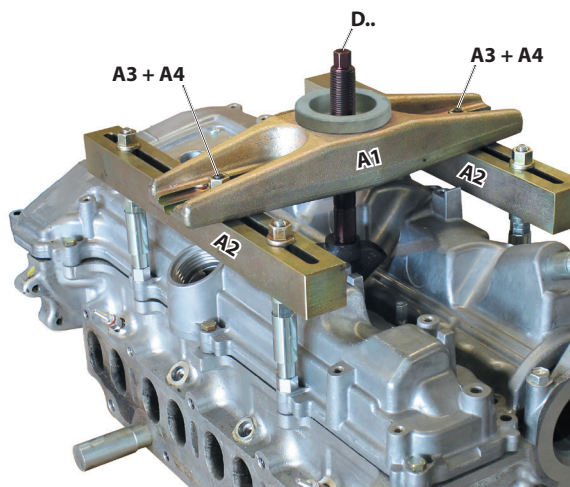

4. Mount the base plate [A1] as shown in 📷 15 over the traction spindle [D..] on the support strips [A2], and secure it by tightening the screws [A4] and collar nuts [A3] with 5 Nm.

⚠️ WARNING

The injector extractor may break if a machine-operated drive is used; ejected parts may lead to **DEATH** or **SERIOUS INJURIES!**

- ▼ Use the injector extractor **exclusively** with a muscle-powered, manually operated drive, or a muscle-powered, manually operated **GEDORE Automotive** hydraulic cylinder / pump combination with a manometer for reliable pressure control!
- ▼ When using the hydraulic cylinder [Z2], secure it against flinging over by using the safety retaining belt [Z3] and attach it to the engine!

⚠️ CAUTION

The draw spindle [D.] can seize up when using the mechanical drive and thus be damaged.

- ▼ Before each use, lubricate the pulling spindle [D.] with molybdenum disulphide paste (for example, **KL-0014-0030**).

📷 16: Prepare as follows, depending on the drive type:

A Mechanical drive

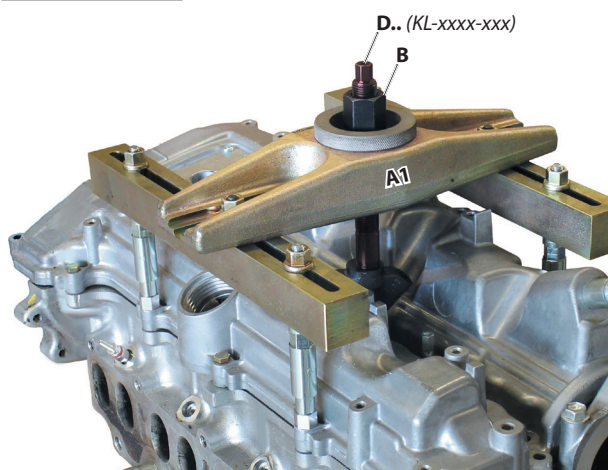

B Hydraulic drive

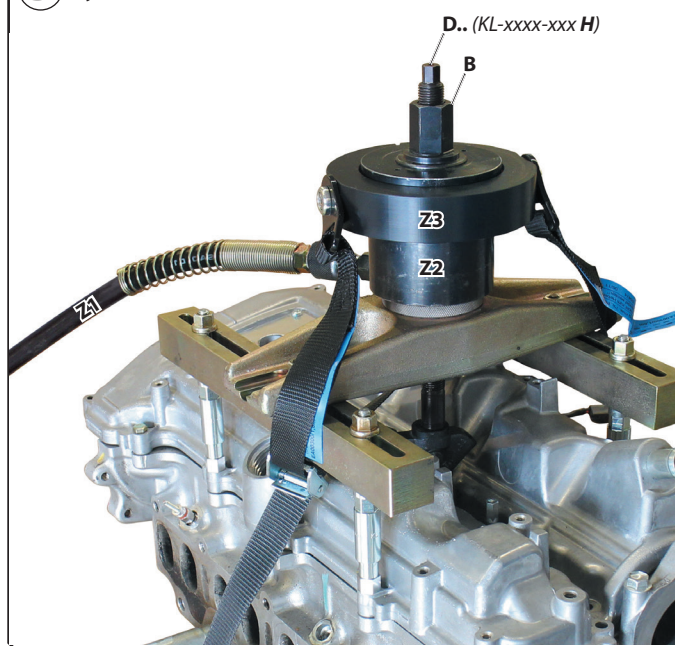

5. Preparing the injector extractor with ...

... mechanical drive:

As shown in 📷 16A, Screw the collar nut [B] onto the draw spindle [D..] by hand until it contacts the base plate [A1].

... hydraulic drive:

Mount the hydraulic cylinder [Z2] as shown in 📷 16B, ⓘ in the **correct position** over the draw spindle [D..] and secure it to the engine using the safety harness [Z3].

- ⓘ Observe the direction of pull/pressure on the hydraulic cylinder [Z2]!

Then screw the collar nut [B] by hand on the draw spindle [D..] until it contacts the hydraulic cylinder [Z2].

📷 16B.

Connect the hydraulic pump [Z1] to the hydraulic cylinder [Z2].

17: Depending on the drive type, remove the injector accordingly:

A Mechanical drive

D.. = Wrench size 10 mm
B = Wrench size 24 mm



Max. 12 tonnes

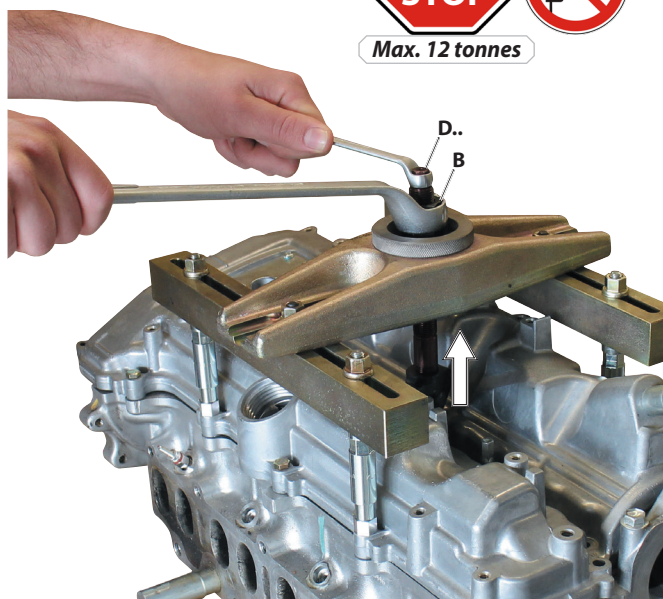

B Hydraulic drive



Max. 12 tonnes

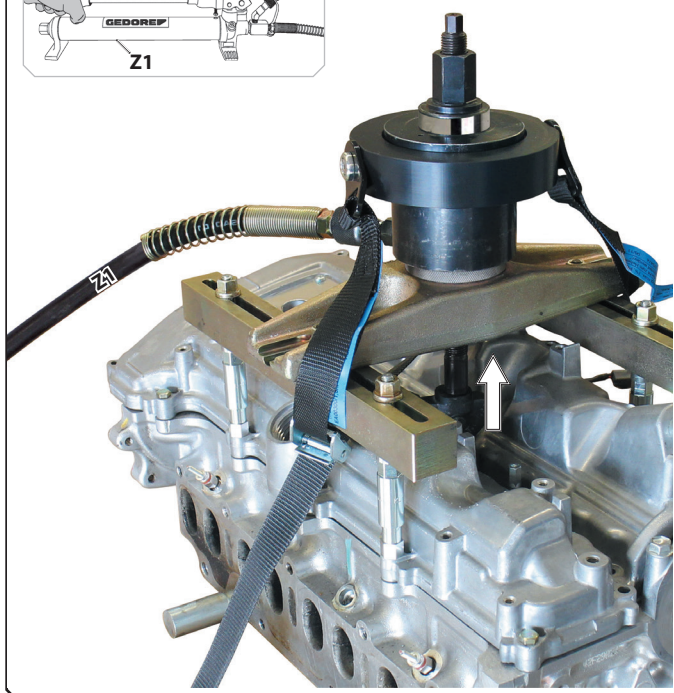
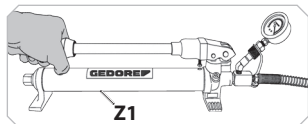

4.4 Removing the injector

⚠ WARNING

When removing a stuck injector, there is a risk of breaking the draw spindle [D..] and/or the injector; therefore, there is a risk of parts flying about. This can result in **DEATH** or **SEVERE INJURIES!**

- ▼ **Never** stand in axial extension of the draw spindle [D..] while it is subject to tension!
- ▼ **Never** exceed the **maximum load** of 12 tonnes!
- ▼ If you use a mechanical drive for the collar nut, counterhold [B] the tension spindle [D..].
- ▼ Finish the disassembly process at the latest when the draw spindle has reached the stop!

1. Removing the injector with a...

... mechanical drive:

Unscrew the collar nut [B] clockwise onto the draw spindle [D..] and pull out the stuck injector **17A**.

... hydraulic drive:

Operate the hydraulic pump [Z1], observe the pressure at the pressure gauge, and pull out the stuck injector **17B**.

Expert's tip: If the injector is extremely stuck, first treat it with rust solvent and subject it to tension for a while with approx. 8 t using the injector extractor. Alternately loosening and re-applying tension should release the injector.

2. Clean the injector hole on the cylinder head before installing a new injector; use cleaning tool - **KL-0186-50 B**, for example.

5. Care and storage

CAUTION Benzene and chemical solvents can damage plastic parts. After each use, clean all parts with a clean cloth only. To protect them against corrosion, lightly rub all metal parts after use with an anti-corrosion oil or wax that is suitable for tool care. Keep the special tool in a dry and clean place.

6. Maintenance and repair

⚠ WARNING If you detect damage to the special tool, it must no longer be used for safety reasons! A professional inspection and repair may only be carried out by specially trained specialist personnel at **GEDORE Automotive GmbH**. Improper repair of the special tool can result in **DEATH** or **SEVERE INJURIES**.

18: KL-0186-130 A

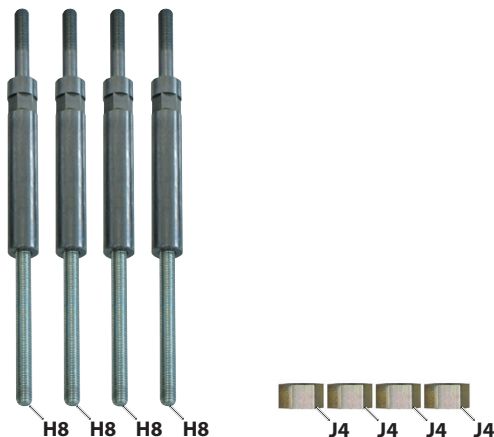

19: KL-0186-132

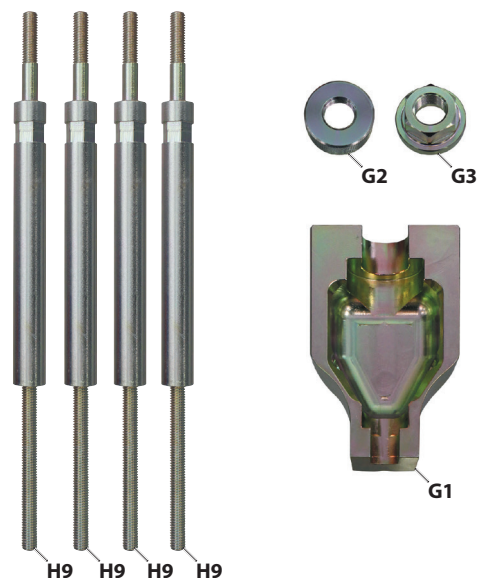

20: KL-0186-1233

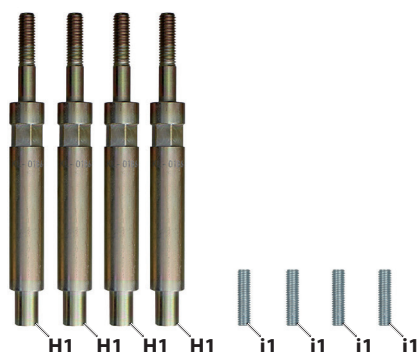

7. Support pins/Supplementary kits

By using the optionally available support pins/supplementary kits, the injector extractor - **KL-0186-14 EA** is also suitable for many other common rail diesel engines.

Select the **support pin kit** according to the engine.

Select the **supplementary kit** according to the injector.

KL-0186-130 A - Support pin / supplementary kit (Fiat, Citroën, Peugeot, Iveco)

Fits Fiat Ducato, Citroën Relay/Jumper III, Peugeot Boxer III, and Iveco 2.3; 2.4 and 3.0 JTD / HDI common rail Diesel engines (engine code: F1CE3481E, F1CE3481M, F1CE3481N, F30DTE [F1CE3481D, F1CE3481DM, F1CE3481E, F1CE3481N] - as per Euro 5), as well as Alfa Romeo 1.9 JTD (Engine code: 937A5.000).

Necessary accessories:

Depending on the injector, the supplementary kit - **KL-0186-128..** may be required.

Pos.	Part no.	Description	Qty.
H8	KL-0186-1232-1	Support pin 120mm, M8	4
J4	KL-0186-1261-1	Spacer nut M8 x 10mm	4

KL-0186-132 - Support pin / supplementary kit (Fiat, Citroën, Peugeot)

Fits **strongly tight-fitting injectors** on Fiat Ducato 3.0 JTD (Euro 5), Citroën Relay/Jumper III, and Peugeot Boxer III 3.0 HDI (Euro 5) common rail diesel engines. (Engine code: F1CE3481E, F1CE3481M, F1CE3481N, F30DTE [F1CE 3481D, F1CE 3481DM, F1CE 3481E, F1CE 3481N])

By inserting the special draw hook, the injector is unlikely to break and can be pulled out in one piece.

Pos.	Part no.	Description	Qty.
H9	KL-0186-1232-1 L	Support pin 175mm, M8	4
G1	KL-0186-1321	Draw hook	1
G2	KL-0186-1322	Knurled nut	1
G3	KL-0186-1323	Hexagon nut	1

KL-0186-1233 - Support pin kit (VW-Audi, Seat, Škoda, Mercedes, Opel, Chevrolet, Peugeot, Citroën, Fiat, Ford)

Fits diesel engines on VW-Audi, Seat and Škoda 2.0 TDI (CFFB); Opel & Chevrolet 2.0 + 2.2 CDTi/VCDi (Z20DM, Z20DMH, Z20S, Z20D1, Z22DMH); Mercedes 1.8 + 2.1 CDI (OM651); Ford 2.2 TDCI (4HM, 4HU, 4HV), and Peugeot, Citroën, Fiat, PSA 2.2 HDI (CYFA, CYFB, CYFC, DRFA, DRFB, DRFC, P22DTE, P8FB, PGFA, PGFB, SRFA, SRFB, SRFC, SRFD, SRFE, UHFA, USRA).

For example installed on VW Golf VI (5K), Eos (1F), Sharan (7N), Passat V (3C), Passat VI (36), Jetta (16), Passat CC (35), Tiguan (5N); Audi A3 (8P), Q3 (8U); Seat Alhambra (71); Škoda Superb II (3T); Opel Antara; Chevrolet Cruze (J300), Captiva, Orlando (J309), Nubria, Lacetti; Mercedes C-Class (W204 / S204 from 2007), E-Class (W212 from 2009), E-Class Coupé / Cabriolet (W207 / C207 from 2009), GLK (X204 from 2008) and Sprinter II (906 from 2006); Ford Transit (from 2006), Tourneo; Fiat Ducato (between 2006 and 2012); Citroën Relay/Jumper III; Peugeot Boxer III.

Necessary accessories:

Depending on the injector, the supplementary kit - **KL-0186-128..** may be required.

Pos.	Part no.	Description	Qty.
H1	KL-0186-1232-10	Support pin 120mm, M8	4
i1	KL-0186-1232-2 A	Grub screw M8 x 88mm	4

21: KL-0186-1234

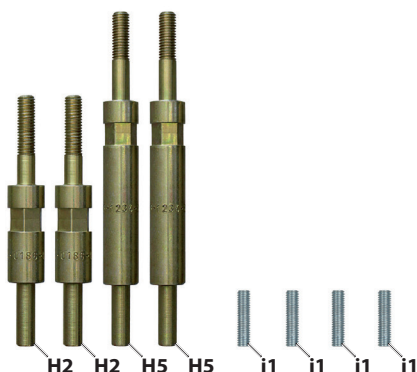

KL-0186-1234 - Support pin kit (Renault, Nissan, Opel)

Fits Renault, Nissan, Opel 2.2 and 2.5 dci diesel engines. (Engine code: G9T and G9U) For example, installed on Renault Avantime, Espace III, Espace IV, Laguna II, Master II, Master III, Traffic II, Vel Satis; Nissan Interstar, Primastar, and Opel Movano, Vivaro.

Necessary accessories:

Depending on the injector, the supplementary kit - **KL-0186-128..** may be required.

Pos.	Part no.	Description	Qty.
H2	KL-0186-1234-10	Support pin 113.5mm, M6	2
H5	KL-0186-1234-20	Support pin 153.5mm, M6	2
i1	KL-0186-1235-2	Grub screw M6 x 25mm	4

22: KL-0186-1236

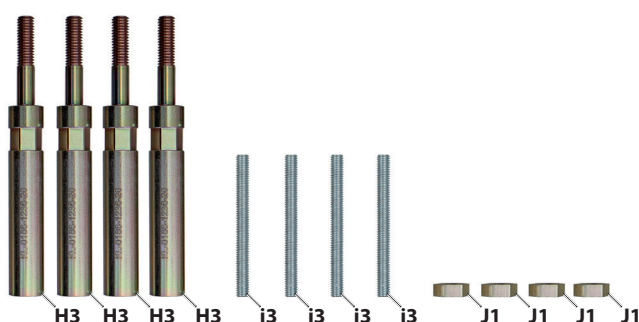

KL-0186-1236 - Support pin kit (Renault, Nissan, Opel)

Fits Renault, Nissan, and Opel 2.0 dci diesel engines. (Engine code: M9R)

Necessary accessories:

Depending on the injector, the supplementary kit - **KL-0186-128..** may be required.

Pos.	Part no.	Description	Qty.
H3	KL-0186-1236-20	Support pin 129 mm, M6	4
i3	KL-0186-1235-4	Grub screw M6 x 6mm	4
J1	KL-0186-1251-1	Spacer nut M6 x 5mm	4

23: KL-0186-1238

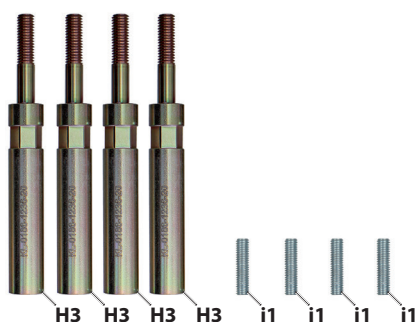

KL-0186-1238 - Support pin kit (Opel, Renault)

Suitable for diesel engines on Opel 1.7 + 3.0 CDTi (A17DT, A17DTC, A17DTJ, A17DTR, Z30DT, Y30DT) and Renault 3.0 dCi (P9X* - V-engines: engine removal may be necessary for space reasons)

For example, installed on Opel Astra H, Astra J, Meriva B, Zafira B, Vectra C, Signum; Renault: Espace (IV), Vel Satis.

Necessary accessories:

Depending on the injector, the supplementary kit - **KL-0186-128..** may be required.

Pos.	Part no.	Description	Qty.
H3	KL-0186-1236-20	Support pin 129mm, M6	4
i1	KL-0186-1235-2	Grub screw M6 x 25mm	4

24: KL-0186-1239

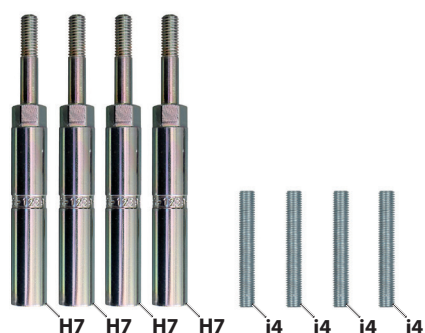

KL-0186-1239 - Support pin kit (Opel, Fiat)

Fits Opel and Fiat 1.3 common rail diesel engines. For example, installed on Opel Agila, Corsa C, Corsa D, Meriva A, Meriva B, Tigra B; Fiat Punto (188), Idea (135), Doblò (223), Doblò (263). (Engine code: Z13DT, Z13DTH, Z13DTC, Z13DTJ, 188A9.000)

Necessary accessories:

Depending on the injector, the supplementary kit - **KL-0186-128..** may be required.

Pos.	Part no.	Description	Qty.
H7	KL-0186-1239-10	Support pin 128.5mm, M7	4
i4	KL-0186-1235-6	Grub screw M7 x 55mm	4

📷 25: KL-0186-1240

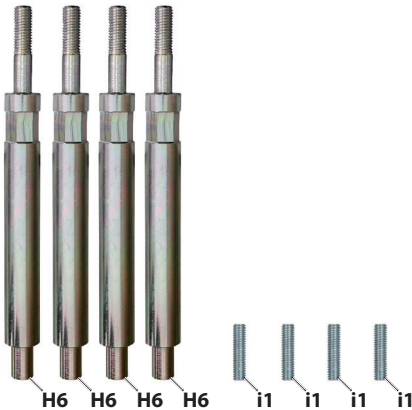

KL-0186-1240 - Support pin kit (BMW, MINI)

Fits BMW 1.6, 2.0 (N47) and 3.0 (N57) as well as MINI 1.6 and 2.0 (N47) common rail diesel engines. For example, installed on BMW 1 series (E81, E82, E87, E88; F20, F21), 2 series (F22), 3 series (E90, E91, E92, E93; F30, F31; F34), 4 series (F32), 5 series (E60, E61; F10, F11; F07), 6 series (F06, F12, F13), 7 series (F01, F02, F04), X1 (E84), X3 (E83; F25), X5 (E70; F15), X6 (71, E72), and MINI Clubman (R55), Clubvan (R55), Countryman (R60), Paceman (R61), Coupe (R58), Roadster (R59), etc.

Necessary accessories:

Depending on the injector, the supplementary kit - **KL-0186-128..** may be required.

Pos.	Part no.	Description	Qty.
H6	KL-0186-1240-10	Support pin 170mm, M6	4
i1	KL-0186-1235-2	Grub screw M6 x 25mm	4

📷 26: KL-0186-1281



KL-0186-1281 - Supplementary kit (Siemens injector with M25x1 IG) (VW, Audi, Seat, Škoda)

Fits Siemens injectors with an internal thread of M25x1 and a wrench size of 25mm.

For example, fits particularly with VW, Audi, Seat, Škoda 1.6 TDI (CAYA, CAYB, CAYC, CAYD, CAYE, CLNA)

Necessary accessories:

Depending on the injector, the supporting pin kit - **KL-0186-12../-13..** may be required.

Pos.	Part no.	Description	Qty.
D9	KL-1383-1021	Draw spindle M25x1 / 132mm	1
C1	KL-1383-1022	Socket wrench size 25mm	1

Alternative drive:

Injector extractor adapter - **KL-0369-4111** and impact extractor **KL-0049-300** (4.8kg) or **KL-0369-4100** (1.5kg)

📷 27: KL-0186-1282



KL-0186-1282 - Supplementary kit (Siemens injector with M27x1 IG)

Fits Siemens injectors with an internal thread of M27x1 and a wrench size of 27 mm.

Necessary accessories:

Depending on the injector, the supporting pin kit - **KL-0186-12../-13..** may be required.

Pos.	Part no.	Description	Qty.
D10	KL-1383-1221	Draw spindle M27x1 / 127mm	1
C2	KL-1383-1222 A	Socket wrench size 27mm	1

Alternative drive:

Injector extractor adapter - **KL-0369-4111** and impact extractor **KL-0049-300** (4.8 kg) or **KL-0369-4100** (1.5 kg)

📷 28: KL-0186-1283

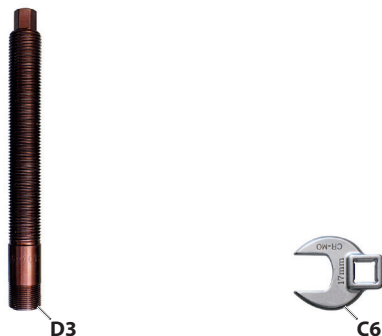

KL-0186-1283 - Supplementary kit (Denso injector with M16x1 IG)

Fits Denso injectors with an internal thread of M16x1 and a wrench size of 17mm.

Necessary accessories:

Depending on the injector, the supporting pin kit - **KL-0186-12../-13..** may be required.

Pos.	Part no.	Description	Qty.
D3	KL-0186-1612	Draw spindle M16x1 / 145mm	1
C6	KL-4417-17 A	Socket wrench size 17mm	1

Alternative drive:

Injector extractor adapter - **KL-0369-4111** and impact extractor **KL-0049-300** (4.8 kg) or **KL-0369-4100** (1.5 kg)

📷 29: KL-0186-1284



KL-0186-1284 - Supplementary kit (Denso injector with M20x1 IG)

Fits Denso injectors with an internal thread of M20x1 and an external thread of M25x0.5 / M25x0.75 and a wrench size of 27mm.

Necessary accessories:

Depending on the injector, the supporting pin kit - **KL-0186-12../-13..** may be required.

Pos.	Part no.	Description	Qty.
D7	KL-0186-1611-1	Draw spindle M20x1 / 145mm	1
E1	KL-0186-1611-2	Union nut M25x0.5mm	1
E2	KL-0186-1611-3	Union nut M25x0.75mm	1
C2	KL-1383-1222 A	Socket wrench size 27mm	1
C5	KL-0186-2201	Special insert	1

Alternative drive:

Injector extractor adapter - **KL-0369-4111** and impact extractor **KL-0049-300** (4.8 kg) or **KL-0369-4100** (1.5 kg)

📷 30: KL-0186-1285

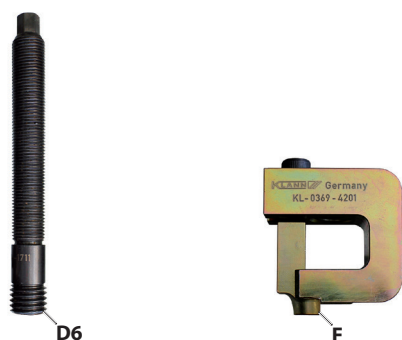

KL-0186-1285 - Supplementary kit (Denso + Bosch injectors with M18x2 IG)

Suitable for Delphi / Bosch injectors with lateral fuel connection (90° angle to the injector).

Necessary accessories:

Depending on the injector, the supporting pin kit - **KL-0186-12../-13..** may be required.

Pos.	Part no.	Description	Qty.
D6	KL-0186-1711	Draw spindle M18x2.5 / 145mm	1
F	KL-0369-420	Nozzle extractor	1

Alternative drive:

Impact extractor **KL-0049-300** (4.8 kg) or **KL-0369-4100** (1.5kg)

31: KL-0186-122

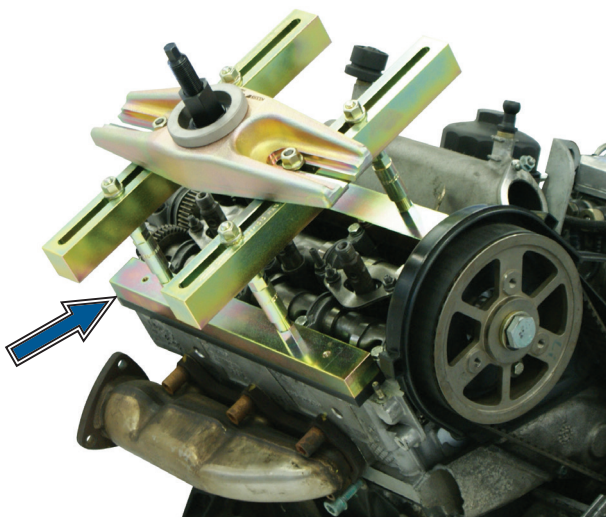

KL-0186-122 - Support strip kit

Allows the injector extractor **KL-0186-14 EA / KA** to be supported on a smooth surface.

If no support is possible on the holes for the valve cover bolts, but the cylinder head has smooth and stable contact surfaces, for example after removing the valve cover, you can use the support strips - **KL-0186-122** as an alternative for screwing in the support pins.

Pos.	Part no.	Description	Qty.
V	KL-0186-1220	Support strip	2

EN

32: KL-0369-4111



KL-0369-4111 - Injector extractor adapter

For extracting injectors which are slightly stuck, in conjunction with a suitable **GEDORE** draw spindle and an impact extractor.

Specifications:

Mounting thread for impact extractor:M18x2.5mm

Mounting thread for draw spindle:M16x1.5mm

Necessary accessories:

Matching draw spindle of the **KL-0186-..series**, **KL-0583-..series**, or **KL-1383-..series**.

Necessary drive:

Impact extractor **KL-0049-300** (4.8kg) or **KL-0369-4100** (1.5kg)

8. Environmentally compliant disposal

Dispose of special tool and packaging material in accordance with the legal requirements in an environmentally friendly manner.

9. Manufacturer's address

GEDORE Automotive GmbH

Breslauer Straße 41 // 78166 Donaueschingen - GERMANY

Phone: +49 771 83223 -71 // E-mail: info.gam@gedore.com