

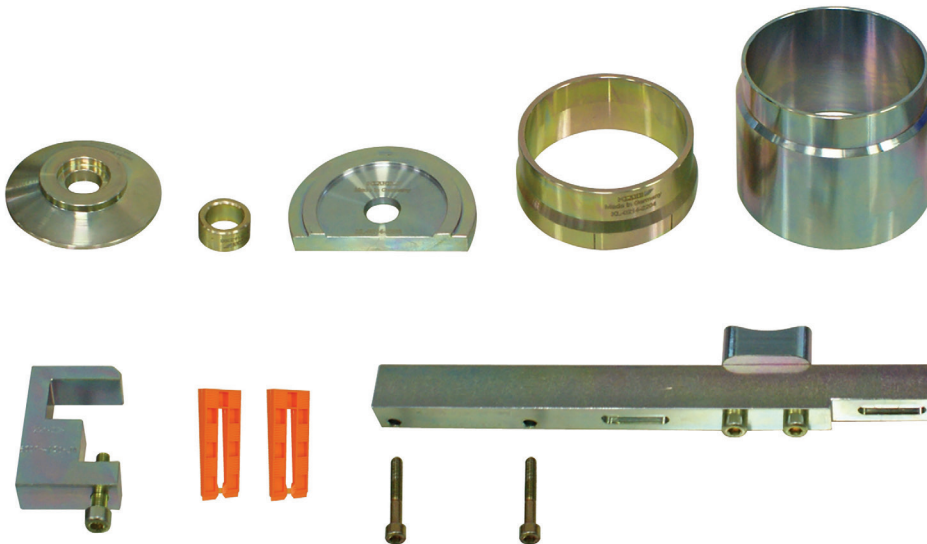

## KL-0214-221 / -220 A

### Double Silent Block Tool VW-Audi



**Operating instructions** EN  
 ⚠ Read and understand before use!

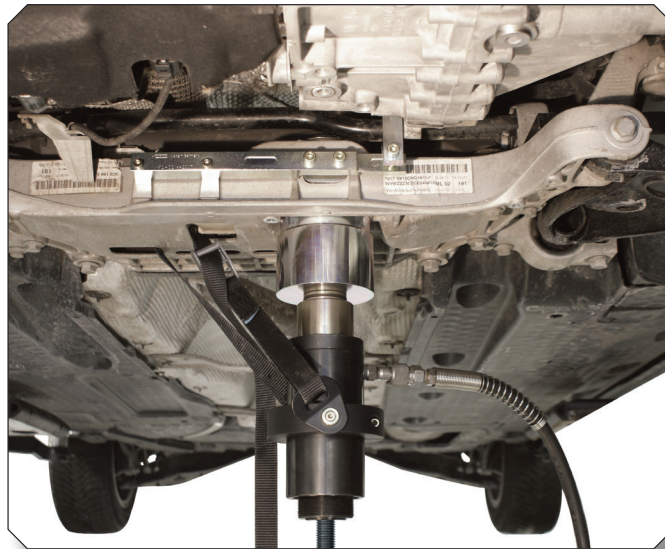

[www.gedore-automotive.com](http://www.gedore-automotive.com)



**GEDORE Automotive GmbH**

Breslauer Straße 41  
 78166 - Donaueschingen  
 Postfach 1329  
 78154 Donaueschingen - GERMANY

☎ +49 (0) 771 / 8 32 23-0  
 ☎ +49 (0) 771 / 8 32 23-90  
 ✉ info.gam@gedore.com  
 🌐 gedore-automotive.com

**GEDORE TOOLS, INC.**

Only for USA, Canada & Mexico / Sólo para EE.UU., Canadá y México  
 Seulement pour les USA, le Canada et le Mexique  
 7187 Bryhawke Circle, Suite 700  
 North Charleston, SC 29418, USA

☎ +1-843 / 225 50 15  
 ☎ +1-843 / 225 50 20  
 ✉ info@gedoretools.com  
 🌐 gedore.com

Version 07/2022



**ENGLISH**

**EN**

## Address of the manufacturer

**GEDORE Automotive GmbH**

Breslauer Straße 41 // 78166 Donaueschingen - GERMANY

☎ +49 (0)771/83223-71 // ✉ info.gam@gedore.com

## Imprint

In the course of improvement and adaptation to the state of the art, we reserve the right to make changes with regard to appearance, dimensions, weights and properties, and performance.

This does not imply any claim to correction or subsequent delivery of already delivered products. Deletions can be made at any time without any legal claim arising.

Instructions for use and safety are not binding. They never substitute for any legal or trade association regulations.

We do not accept any liability for printing errors.

Any reproduction, in whole or in part, requires the prior written consent of **GEDORE Automotive GmbH**.

All rights reserved worldwide.

© Copyright by **GEDORE Automotive GmbH** Donaueschingen (GERMANY)

We refer to our general terms and conditions, which can be found in the imprint at:

[www.gedore-automotive.com](http://www.gedore-automotive.com)



## CONTENTS

<b>1. READ AND UNDERSTAND FOR YOUR SAFETY</b> .....	<b>4</b>
1.1 Target group.....	4
1.2 Obligations of the owner.....	4
1.3 Intended use .....	4
1.4 Reasonably foreseeable misuse .....	4
1.5 Personal protective equipment.....	5
1.6 Labelling of the warnings.....	5
1.7 Basic warnings .....	5
1.8 Basic safety instructions .....	6
1.9 Work environment .....	7
1.10 Emissions.....	7
1.11 Maintenance .....	7
1.12 Troubleshooting.....	7
<b>2. PRODUCT DESCRIPTION</b> .....	<b>8</b>
2.1 KL-0214-221 - Double silent block tool VW-Audi.....	8
2.2 Scope of delivery / spare parts overview .....	8
2.3 Specifications.....	8
<b>3. PREPARATION</b> .....	<b>9</b>
3.1 Checking the scope of delivery .....	9
3.2 Required drive parts .....	9
3.3 Preparing the pulling device.....	10
3.4 Preparing the vehicle .....	10
<b>4. TYPICAL APPLICATION</b> .....	<b>11</b>
4.1 Assembly of the clamping device .....	11
4.2 Forcing out the double silent block.....	11
4.3 Forcing in the double silent block .....	13
<b>5. CARE / STORAGE</b> .....	<b>15</b>
<b>6. REPAIR</b> .....	<b>16</b>
<b>7. OTHER TOOLKITS</b> .....	<b>16</b>
<b>8. ENVIRONMENTALLY FRIENDLY DISPOSAL</b> .....	<b>16</b>

## 1. READ AND UNDERSTAND FOR YOUR SAFETY



Read and understand these operating instructions **before** using the double silent block tool (*pulling device*), and observe all safety and warning instructions! Misuse can result in **DEATH** or **SEVERE INJURIES** ! These operating instructions are an integral part of the pulling device. Keep them at a safe place for future reference, and always pass them on to subsequent users of the pulling device. The pulling device complies with the recognised rules of technology as well as the relevant safety regulations.

### 1.1 Target group

These operating instructions are **exclusively** intended for skilled personnel in specialised motor vehicle workshops!

The pulling device **may only be** used by skilled personnel in specialised motor vehicle workshops who are familiar with the basic regulations on work safety and accident prevention!

▼ **Never** allow unauthorised, inexperienced persons, minors and children, or persons with limited physical, sensory, and mental abilities to use the the pulling device!

### 1.2 Obligations of the owner

Pursuant to the German Ordinance on Industrial Safety and Health (*BetrSichV*), employers are obliged to provide their employees with safe work equipment in accordance with the recognised rules of technology and the relevant safety regulations!

▼ The owner of the pulling device **must** ensure that **only** trained personnel in specialised vehicle workshops use the pulling device!

▼ The owner of the pulling device **must** ensure that the operating instructions are available to the user and that the user has completely read and understood the operating instructions **before** using the pulling device!

▼ The owner of the pulling device **must** ensure that the user is familiar with the basic regulations on work safety and accident prevention, and that personal protective equipment is available to him!

### 1.3 Intended use

The pulling device ...

▼ **May only be** used for forcing out and in double silent blocks for the torque arm on unit carriers of aluminium!

▼ **may only** be used on vehicles as specified in **Chapter 2. - Product description!**

▼ **may only** be used up to a **max. load of 7 tonnes!**

▼ **may only** be operated by hand with muscle power with a manual drive or a manually operated **GEDORE Automotive** hydraulic cylinder/pump combination with pressure gauge for safe pressure control!

▼ **may only** be used with **GEDORE Automotive** genuine spare parts and accessories!

▼ **may only** be used in the way described in these operating instructions!

▲ Any other use can result in **DEATH** or **SEVERE INJURIES** !

### 1.4 Reasonably foreseeable misuse

The pulling device ...

▼ **must never** be used for forcing out or in other parts than those intended for it!

▼ **must never** be used together with an impulse or impact screwdriver!

▼ **must never** be used with a machine-operated drive or a machine-operated hydraulic cylinder/pump combination!

▼ **must never** be used with a drive other than that intended for it!

▼ **must never** be used for batch processing with many forcing in/out processes within a few minutes!

▼ **must never** be used with a bridged, modified, or removed safety device!

▼ **must never** be modified, converted, or used for other purposes without authorisation!

▲ Use the pulling device **always** as intended. Any other use can result in **DEATH** or in **SEVERE INJURIES!**

### 1.5 Personal protective equipment

For your safety, **always** wear personal protective equipment when using the pulling device! The pulling device can bring about mechanical hazards, such as crushing, cutting, and shock injuries.



Always wear **EYE PROTECTION** (see DIN EN 166, OSHA 29 CFR 1910.133, ANSI Z87) when using the pulling device to protect yourself against parts or particles flying about!

When using the pulling device, flying parts or particles can cause **SEVERE INJURIES** to your **eyes!**



Always wear **PROTECTIVE GLOVES** (e.g. DIN EN 388, OSHA 29 CFR 1910.138, ANSI 105) when using the pulling device to protect yourself against sharp edges and crushing between parts!

When working with the pulling device, sharp edges and crushing between parts can cause **SEVERE INJURIES** to your **hands!**



Always wear **SAFETY SHOES** (for example to DIN EN ISO 20345, OSHA 29 CFR 1910.136, ANSI Z41) when using the pulling device to protect yourself against dropping parts!

When working with the pulling device, falling parts can cause **SEVERE INJURIES** to your **feet and toes!**

EN

### 1.6 Labelling of the warnings

Warnings warn of potential **hazards**. **Always** observe these warnings to avoid **DEATH** or **INJURIES!**

For better differentiation, warnings in these operating instructions are classified as follows:	
Warning sign	Meaning
	Indicates a hazardous situation which, if not avoided, could cause <b>DEATH</b> or <b>SEVERE INJURIES</b> .
	Indicates a hazardous situation which, if not avoided, could cause <b>MODERATE</b> or <b>MINOR INJURIES</b> .
	Indicates a situation which, if not avoided, can cause damage to the tool or an object in its vicinity.
	<b>Note</b> on important information and useful tips.

### 1.7 Basic warnings

#### **WARNING - Danger to life from MISUSE**

**MISUSE** can cause the pulling device to slip, break, and thus drop or be hurled about. This can cause **DEATH** or **SEVERE INJURIES!**

- When reading and understanding these operating instructions **before using** the oil pump, and observe all safety and warning instructions for **safe use!**
- Always** work with the pulling device in accordance with the basic regulations on work safety and accident prevention!
- Only** use the pulling device as intended and described in these operating instructions!
- Always** observe the vehicle-specific application procedures in the repair guide of the vehicle manufacturer!
- Never** use the pulling device if it is damaged or has loose parts or unauthorised modifications!
- Always** secure the pulling device against falling down and flinging around, for example via the **GEDORE** safety harness - **KL-0040-2590** or **KL-0040-2592!**
- Always** secure the pulling device against falling down and flinging around!
- Never** use the pulling device with an impulse or impact spanner!
- Never** use the pulling device with a machine-operated drive or any other drive than intended! Drive it only by hand and with muscle power; **only** use a manual drive or a manually operated **GEDORE Automotive** hydraulic cylinder / pump combination with a pressure gauge for safe pressure control!
- Never** use the pulling device for batch processing with numerous forcing in/out processes within a few minutes!
- Always** wear your personal protective equipment (*safety goggles, protective gloves, safety shoes*) during work!
- Never** beat the pulling device with a hammer or anything similar!



## ⚠ WARNING - Danger to life from OVERLOAD

**OVERLOAD** can cause the pulling device to slip, break, and thus drop or be hurled about. This can cause **DEATH** or **SEVERE INJURIES!**

- ✔ **Never** exceed the **maximum loading capacity** of the pulling device!
- ✔ **Never** use the pulling device if it is damaged or has loose parts or unauthorised modifications!
- ✔ **Never** use the pulling device with a machine-operated drive or any other drive than intended! Drive it **only** by hand and with muscle power; use a manual drive or a manually operated **GEDORE Automotive** hydraulic cylinder/pump combination with a pressure gauge for safe pressure control!
- ✔ **Never** use the pulling device for batch processing with numerous forcing in/out processes within a few minutes!
- ✔ **Always** wear your personal protective equipment (*safety goggles, protective gloves, safety shoes*) during work!

## ⚠ CAUTION - Risk of injury from DROPPING and FLINGING AROUND

There is a risk of the pulling device **DROPPING** or **FLINGING AROUND** during preparation and use (overhead, for example). This can cause **SEVERE INJURIES!**

- ✔ **Always** secure the pulling device against falling down and flinging around, for example via the **GEDORE** safety harness - **KL-0040-2590** or **KL-0040-2592!**
- ✔ **Never** stand in axial extension of the pulling device when it is under load!
- ✔ **Always** make sure that the pulling device is securely attached to the vehicle!
- ✔ Avoid dropping the pulling device **at all times**, especially when it is under load!
- ✔ **Never** leave the pulling device unattended in loaded condition on the vehicle!
- ✔ Deposit the pulling device **safely** against falling down, for example on a workbench!
- ✔ **Always** carry out all preparations of heavy parts with the help of a second specialist!
- ✔ **Always** wear your personal protective equipment (*safety goggles, protective gloves, safety shoes*) during work!

## ⚠ ATTENTION - Risk of DAMAGE

The vehicle, the double silent block, the unit carrier, and the pulling device can be **DAMAGED**.

- ✔ **Always** observe the installation position of the double silent block specified by the vehicle manufacturer!
- ✔ **Always** observe vehicle-specific application procedures in the vehicle manufacturer's repair guide.
- ✔ **Prior to each use**, check the moving parts and the spindle of the special tool for sufficient lubrication. If necessary, lubricate it only with molybdenum disulphide paste (for example **GEDORE Automotive - KL-0014-0030**)!
- ✔ **Never** use the pulling device for batch processing with numerous forcing in/out processes within a few minutes!
- ✔ **Never** clamp the pulling device in a vice.

## 1.8 Basic safety instructions

For your safety, **always** observe the following safety precautions when using the pulling device in order to avoid injuries and material damage caused by misuse or unsafe handling.

- ✔ Read and understand these operating instructions **before using** the oil pump, and observe all safety and warning instructions for **safe use!**
- ✔ **Always** observe the vehicle-specific application procedures in the vehicle manufacturer's repair guide!
- ✔ **Always** work with the pulling device in accordance with the basic regulations on work safety and accident prevention!
- ✔ **Never** use the extraction device when you are tired or under the influence of alcohol, drugs, or medication!
- ✔ **Before each use**, check the pulling device **carefully** for damage, loose parts, or unauthorised modifications. **Never** use it if you notice any such deficiencies!
- ✔ Use **only genuine GEDORE Automotive** spare parts and accessories!
- ✔ Carry, lift, and position the pulling device, **if necessary**, get help from a second specialist due to the weight!
- ✔ **Before using** the pulling device, ensure that **no** unauthorised persons are in the immediate environment!
- ✔ **Always** observe the **max. loading capacity** when using the pulling device, and **never** exceed it!
- ✔ **Never** stand in axial extension of the pulling device when it is under load!
- ✔ **Never** use the pulling device with any other drive than intended!
- ✔ **Always** wear your personal protective equipment (*safety goggles, protective gloves, safety shoes*) during work!
- ✔ Interrupt your work **immediately** if you are unsure about using the pulling device, and contact **GEDORE Automotive GmbH** if necessary!

- ▼ Interrupt your work **immediately** if you are unsure about using the pulling device, and contact **GEDORE Automotive GmbH** if necessary!
- ▼ For safety reasons, stop using the pulling device if any damage is detected on it! Professional inspection and repair may only be carried out by specially trained personnel from **GEDORE Automotive GmbH**!
- ▼ **Always** use the pulling device as intended; non-compliance will invalidate any warranty claim and may significantly reduce its durability.

## 1.9 Work environment

For your safety, **only** use the pulling device in a safe working environment.

- ▼ The workplace **must** be clean and tidy.
- ▼ The workplace **must** be sufficiently large and illuminated.
- ▼ The workplace **must** be on a solid and non-skidding floor.
- ▼ The workplace **must** be safeguarded against access of unauthorised persons.
- ▼ The workplace **must** have a room temperature between -10°C and +40°C.

EN

## 1.10 Emissions

Molybdenum disulphide paste and hydraulic oil can drip or escape when using the pulling device and thus pose a hazard to the environment.

- ▼ **Immediately** remove leaking hydraulic oil as well as excess molybdenum disulphide paste (using oil binding agents or a cleaning cloth, for example).
- ▼ In case of skin contact with hydraulic oil, clean the affected area **immediately** with degreasing soap and water.
- ▼ Dispose of pollutants such as hydraulic oil and molybdenum disulphide paste in an **environmentally friendly** manner.
- ▼ Safety data sheets *in accordance with Regulation (EC) No. 1907/2006*, for hydraulic oil (**Alsus Hyd HLP 32**) as well as for molybdenum disulphide paste (**MOLYKOTE® G-N PLUS PASTE**) can be found on the manufacturer's site on the Internet (**World Wide Web**) or, if required, contact **GEDORE Automotive GmbH**.

## 1.11 Maintenance

Perform maintenance on the pulling device **at regular intervals** and **only** when the tool is not subject to tension or pressure! Poor and improper maintenance can damage the pulling device, thus causing **DEATH** or **SEVERE INJURIES**!

**Prior to each use:**

- ▼ **Prior to each use**, check the pulling device **carefully** for damage, loose parts, or unauthorised modifications!
- ▼ **Prior to each use** of the pulling device, check the spindle for contamination and damage. If necessary, clean it and subsequently lubricate it **only** with molybdenum disulphide paste! (For example, **GEDORE Automotive - KL-0014-0030**)

**Recommended: Every 24 months:**

- ▼ Have the pulling device professionally checked **every 24 months** by authorised **GEDORE Automotive GmbH** specialists!

## 1.12 Troubleshooting

**Always** troubleshoot the extraction device when it is depressurised/tension-free.

**Problem:** Clamping nut or spindle on the pulling device sluggish.

**Reason:** The clamping nut and spindle are soiled or insufficiently lubricated, or wrong lubricant was used.

**Remedy:** Clean the clamping nut and spindles, check them for damage, and lubricate them **exclusively** with molybdenum disulphide paste. (For example, **GEDORE Automotive - KL-0014-0030**)

**Problem:** Hydraulic oil escapes from the hydraulic coupling between hydraulic cylinder and hand pump.

**Reason:** Hydraulic coupling contaminated or loose.

**Remedy:** Clean and retighten the hydraulic coupling. Top up lacking hydraulic oil (**HLP 32**) at the hand pump.

**Problem:** The hydraulic hand pump does not build up pressure or only very slowly.

**Reason:** The pressure release valve on the hydraulic hand pump is open or hydraulic oil is missing.

**Remedy:** Close the pressure release valve on the hydraulic pump completely. Top up lacking hydraulic oil (**HLP 32**) at the hydraulic hand pump.

## 2. PRODUCT DESCRIPTION

### 2.1 KL-0214-221 - Double silent block tool VW-Audi, without drive

Suitable for double silent blocks on carriers made of aluminium. For example, installed on VW Golf V (1K), Golf VI (5K, AJ), Caddy III (2K, 2C), EOS (1F), Golf Plus V (5M, 521), Jetta III (1K), Touran (1T), Passat (3C, 362, 365), Scirocco (137), Tiguan (5N); Audi A3 (8P), TT (8J); Seat Altea (5P), Leon (1P), Toledo III (5P); Škoda Octavia (1Z), etc.

The double silent block tool enables quick and professional forcing out and in of double silent blocks (torque arm silent blocks on the unit carrier) directly on the vehicle.

It is not necessary to loosen or remove the unit carrier, or to carry out a subsequent wheel alignment.

EN

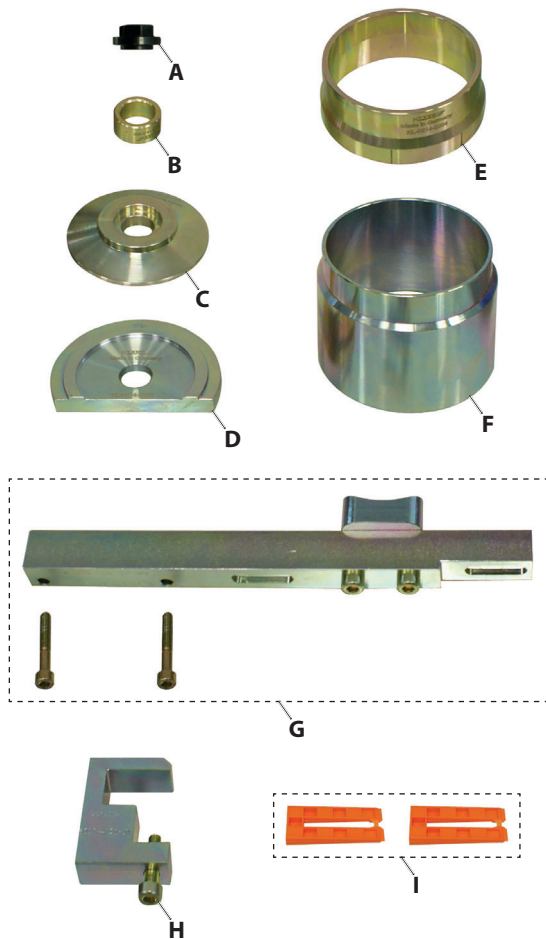

### 2.2 Scope of delivery

Item	Part no.	Description	Qty.
A	KL-0039-1912-3	Hex collar nut M12, flat	1
B	KL-0214-2202	Spacer ring, Ø 30mm	1
C	KL-0214-2201	Thrust piece, Ø 89.5mm	1
D	KL-0214-2203 A	Position plate	1
E	KL-0214-2204	Conical sleeve, Ø 90mm	1
F	KL-0214-2205	Support sleeve, Ø 92.7mm	1
G	KL-0214-2207	Clamping device	1
H	KL-0214-2206	Clamping bracket with screw	1
I	KL-0214-2208	Set of plastic wedges	1

**i** Other tool kits - for example, KL-0214-220 A, see chapter 7.

Required drive parts: see Chapter 3.2



### 2.3 Specifications

Maximum load capacity: ..... 7t



### 3. PREPARATION

#### ⚠ WARNING

Misuse and/or **overload** can cause the pulling device to slip, break, and thus drop or fling around. This can cause **DEATH** or **SEVERE INJURIES!**

- ✔ **Prior to using** the pulling device, read and understand **all** safety instructions and warnings listed in **Chapter 1**, and **always observe** them for safe use!
- ✔ **Use the** pulling device **as intended**, and **always** carry out maintenance and repairs in compliance with the regulations on occupational safety and accident prevention as well as the vehicle manufacturer's instructions!
- ✔ **Before each use**, check the pulling device **carefully** for damage, loose parts, or unauthorised modifications. **Never** use it if you notice any such deficiencies!
- ✔ **Always** wear your personal protective equipment (*such as safety goggles, protective gloves, safety shoes*) during work!

#### 3.1 Checking the scope of delivery

Prior to preparing or using the pulling device, check that all parts of the scope of delivery are available (*see chapter 2.*), and follow the instructions below.

#### 3.2 Required drive parts

#### ⚠ WARNING

Using a machine-operated drive can cause the pulling device to break and thus drop or fling around. This can cause **DEATH** or **SEVERE INJURIES!**

- ✔ **Never** use the pulling device with an impulse or impact spanner!
- ✔ **Never** use the pulling device with a machine-operated drive or any other drive than intended! Drive it only by hand and with muscle power; **only** use a manual drive or a manually operated **GEDORE Automotive** hydraulic cylinder / pump combination with a pressure gauge for safe pressure control!

1. Assemble the required drive parts for the pulling device, either **HYDRAULICALLY** or **MECHANICALLY**, as shown in **❶ 1**.

❶ The subsequent typical example is described with the use of **hydraulic** drive parts. The procedure with **mechanical** drive parts always follows the same principle.

❶ *For other drive components see the GEDORE Automotive catalogue.*

#### ❶ 1: Required drive parts:

##### HYDRAULIC

optionally

##### MECHANICAL

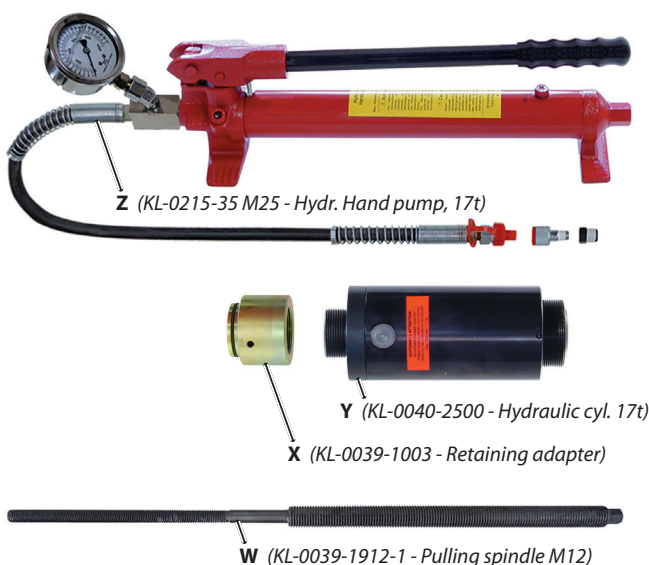

~ To be used in a similar way as **hydraulic** drive parts.

**📸 2:** Prepare the pulling device accordingly.

### HYDRAULIC

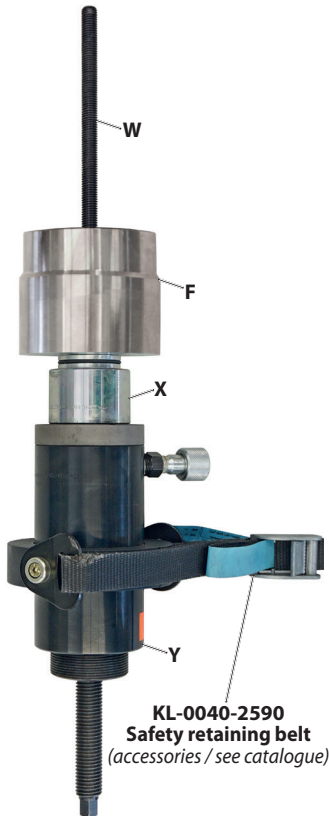

### MECHANICAL

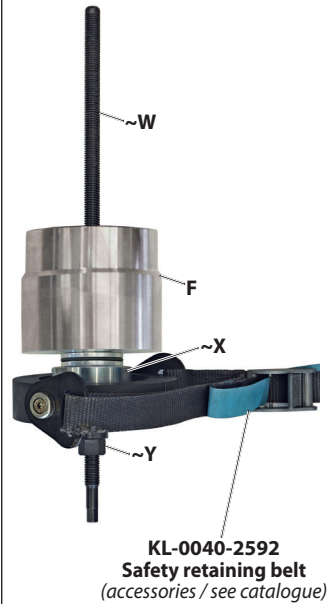

## 3.3 Preparing the pulling device

1. Assemble the pulling device to suit the type of drive (**HYDRAULIC** or **MECHANICAL**) as shown in **📸 2**.

ⓘ The safety harnesses **KL-0040-2590** or **KL-0040-2592**, which are available as an *accessory*, allow easy securing the pulling device against dropping.

## 3.4 Preparing the vehicle

1. Safely lift the vehicle and prepare all necessary parts for the following work in accordance with the manufacturer's instructions.

### For example:

Remove the underride guard and remove the torque arm on the gearbox or unit carrier.

**📸 3:** Prepare the vehicle, loosen the stabiliser and move it upwards by using the plastic wedges [I].

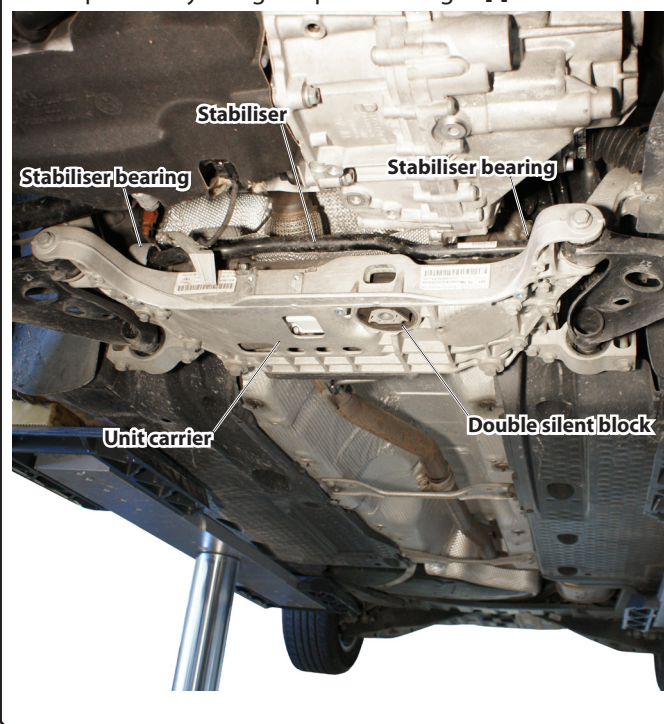

## CAUTION

The pulling device cannot be applied due to the stabiliser.

▼ To make room for the pulling device, loosen the stabiliser!  
2. Loosen both stabiliser bearings according to the manufacturer's instructions, and push the stabiliser slightly upwards with the help of the two plastic wedges [I] **📸 3**.

**📷4:** Mounting the clamping device [G] to the unit carrier.

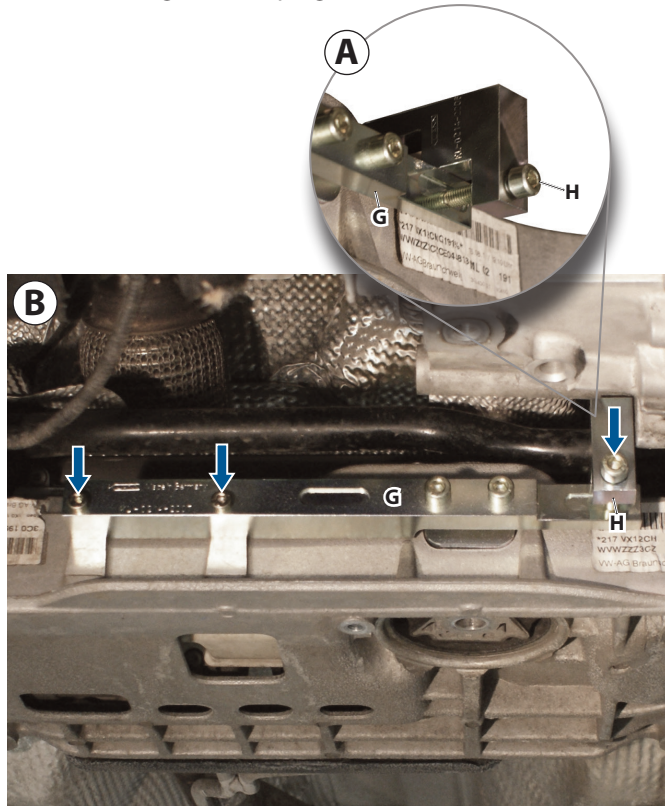

**📷5:** Assembling and positioning the pulling device.

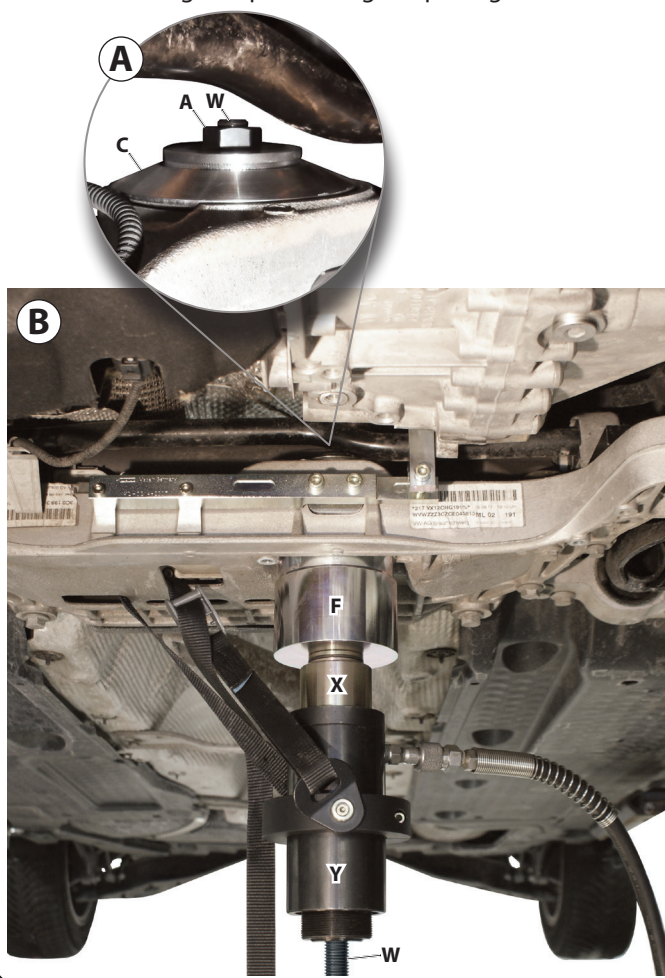

## 4. TYPICAL APPLICATION

This typical application describes the **hydraulic** removal and installation of a double silent block directly on the vehicle, on a unit carrier made of aluminium. The procedure with **mechanical** drive parts always follows the same principle.

### 4.1 Assembly of the clamping device

#### CAUTION

The pulling device, the unit carrier, and the double silent block can be damaged by the open cut-out on the unit carrier during the removal and insertion.

► In order to close the cut-out on the unit carrier, the clamping device [G] **must** be installed first!

1. Screw the clamping device [G] to the unit carrier in the correct position using the associated screws as shown in **📷4B**, and tighten them to **10 Nm**.
2. Place the clamping bracket [H] as shown in **📷4A** on the clamping device [G], and **slightly** tighten the associated screws.

### 4.2 Forcing out the double silent block

1. Place the thrust piece [C] together with the collar nut [A] in the correct position on top of the double silent block as shown in **📷5A**.
2. Insert the pulling device as shown in **📷5B** from below through the double silent block, and screw the collar nut [A] clockwise flush on top of the pulling spindle [W] to **📷5A**.

#### ⚠️WARNING

The collar nut [A] can loosen when unscrewing the hydraulic cylinder [Y], causing the pulling device to drop. This can cause **SEVERE INJURIES**.

- To prevent the collar nut [A] from loosening, counterhold the pulling spindle [W] against the hexagon (**SW 13 mm**) when unscrewing the hydraulic cylinder [Y]!
3. Screw on the hydraulic cylinder [Y] clockwise around the pulling spindle [W] until the support sleeve [F] rests fully and properly on the unit carrier.



**📷6:** Force out the double silent block in a controlled way.



**KL-0040-2590**  
Safety retaining belt  
(accessories / see catalogue)

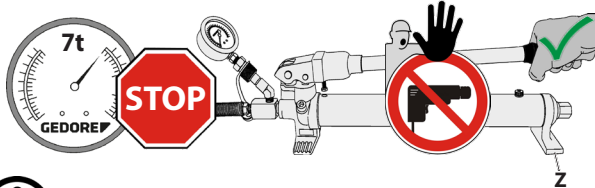

The maximum stroke of the hydraulic cylinder [Y] is 45mm!

**As soon as it is reached:**

Interrupt the forcing procedure, relieve the pressure from the hydraulic pump [Z], re-tighten the quick clamping nut [W] until the forcing sleeve [F] is fully applied, and continue the pressing procedure.

**📷7:** Double silent block removed.

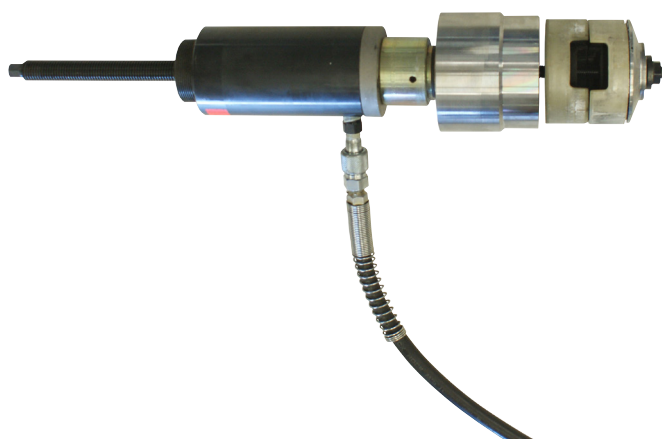

**⚠️WARNING**

There is a risk of the pulling tool dropping when the silent block is removed. This can cause **SEVERE INJURIES!**

► The pulling device **must** always be secured against falling down!

4. Secure the press on the vehicle to prevent it from dropping, for example using the GEDORE safety harness - **KL-0040-2590**.

**⚠️WARNING**

Using a machine-operated drive can cause the pulling device to break and thus drop or fling around. This can cause **DEATH** or **SEVERE INJURIES!**

► **Never** use the pulling device with an impulse or impact spanner!

► **Never** use the pulling device with a machine-operated drive or any other drive than intended! Drive it only by hand and with muscle power; **only** use a manual drive or a manually operated **GEDORE Automotive** hydraulic cylinder / pump with a pressure gauge for safe pressure control!

5. Connect the hydraulic pump [Z] to the hydraulic cylinder [Y]. **📷6**

**⚠️WARNING**

When forcing off double silent blocks, there is a risk of the pull spindle breaking and parts flinging around. This can cause **DEATH** or **SEVERE INJURIES**.

► **Never** exceed the **maximum load** of 7t!

► **Constantly** watch the pressure on the pressure gauge at the hydraulic pump [Z] while forcing off.

► While forcing out, **never** stand in the axial extension of the pull spindle [W].

6. Operate the hydraulic pump [Z], watch the pressure on the pressure gauge, and force the double silent block out of the unit carrier. **📷7**

**🧑Expert's tip:**

🧑 If the double silent blocks are very tight, it is helpful to heat them up, for example with a hot air blower.

7. Unload and disassemble the pulling device.

**📷8:** Align the clamping device [G] with the clamping

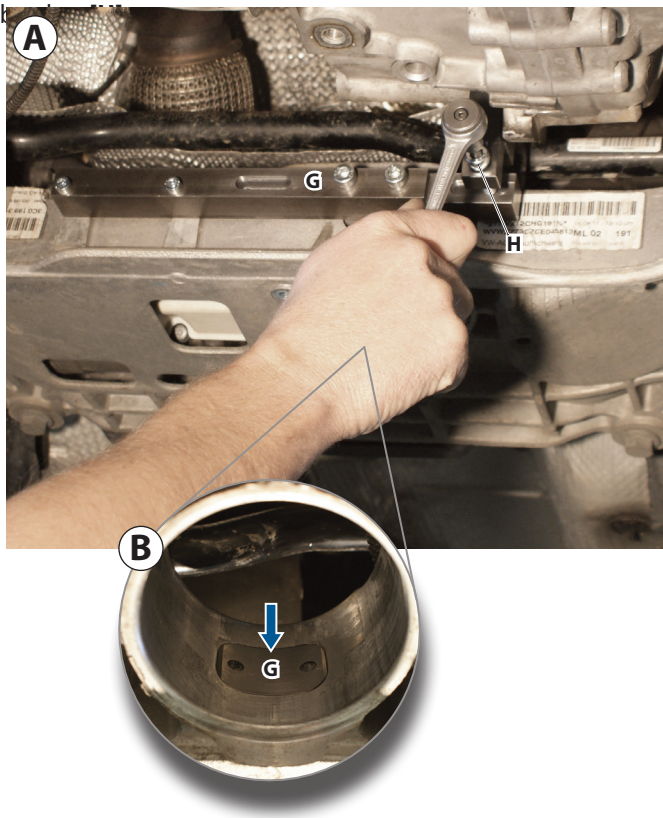

### 4.3 Forcing in the double silent block

#### CAUTION

The double silent block can be damaged by the cut-out on the unit carrier when it is pressed in.

➤ To avoid damage, the clamping device [G] **must be** aligned before installing the silent block!

1. To align the clamping device [G], turn the screw on the clamping bracket [H] **📷8A** clockwise until the clamping device [G] is exactly flush with the inner diameter of the silent block bore **📷8B**

**📷9:** Prepare the pulling device accordingly.

#### HYDRAULIC

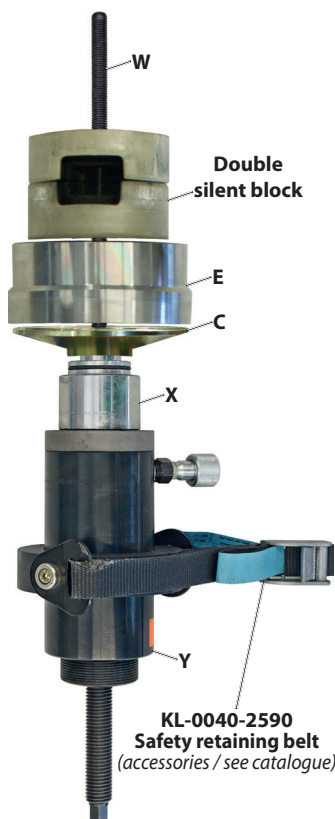

#### MECHANICAL

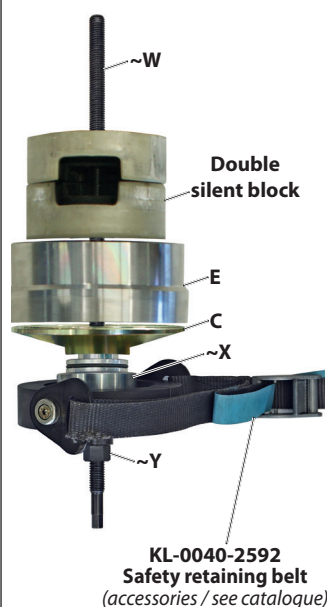

2. Assemble the pulling device with the new double silent block to suit the type of drive (**HYDRAULIC** or **MECHANICAL**) as shown in **📷9**.

ⓘ The safety harnesses **KL-0040-2590** or **KL-0040-2592**, which are available as an *accessory*, allow securing the pulling device against dropping.

3. Clean the silent block bore on the unit carrier, and lubricate it and the new silent block with a suitable assembly paste.



**📷 10:** Mount the pulling device and align the double silent block.

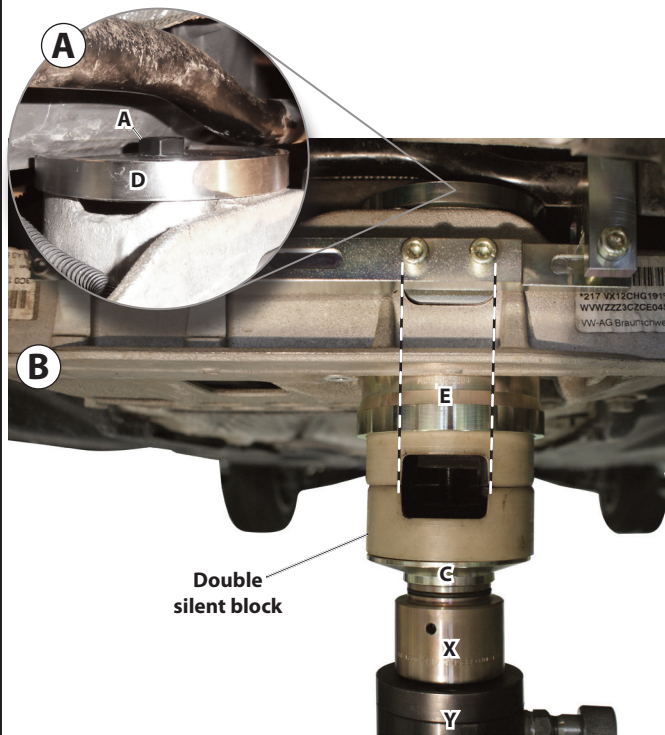

### CAUTION

The double silent block can jam in the silent block bore and thus be damaged.

- ▶ To ensure exact centring of the double silent block, the positioning plate [D] **must be** placed in the correct position (with the flat side facing upwards).
- 4. Place the position plate [D] in the correct position together with the collar nut [A] on top of the silent block bore on the unit carrier as shown in **📷 10A**.
- 5. Insert the pulling device as shown in **📷 10B** from below through the unit carrier, and screw the collar nut [A] clockwise flush on top of the pulling spindle [W] **📷 10A**.

### CAUTION

The double silent block can be incorrectly installed and damaged.

- ▶ Before forcing in the double silent block, align it so that the recesses on the double silent block are exactly in line with the cut-out on the unit carrier **📷 10B**.

### ⚠️ WARNING

The collar nut [A] can loosen when unscrewing the hydraulic cylinder [Y], causing the pulling device to drop. This can cause **SEVERE INJURIES**.

- ▶ To prevent the collar nut [A] from loosening, counterhold the pulling spindle [W] against the hexagon (**SW 13 mm**) when unscrewing the hydraulic cylinder [Y]!
- 6. Screw on the hydraulic cylinder [Y] clockwise around the pulling spindle [W] until the conical sleeve [E] rests fully and properly on the unit carrier. Doing so, counterhold the pulling spindle [W] on the hexagon (**SW 13 mm**)!

**📷 11:** Force in the double silent block as 1st step.



### CAUTION

The double silent block can jam when forcing in and thus be damaged.

- ▶ To counteract jamming, hold and guide the pulling device in a vertical position by hand over the pulling spindle [W] when forcing in.

### ⚠️ WARNING

When forcing in the double silent block, the pulling spindle can break, causing various parts to fling around. This can cause **DEATH** or **SEVERE INJURIES**.

- ▶ **Never** exceed the **maximum load** of 7t!
- ▶ **Constantly** watch the pressure on the pressure gauge at the hydraulic pump [Z] while forcing off.
- ▶ While forcing out, **never** stand in the axial extension of the pull spindle [W].

- 7. While operating the hydraulic pump [Z], watch the pressure on the pressure gauge, and, in a first step, force in the double silent block into the unit carrier until the conical sleeve [E] drops down **📷 11**.

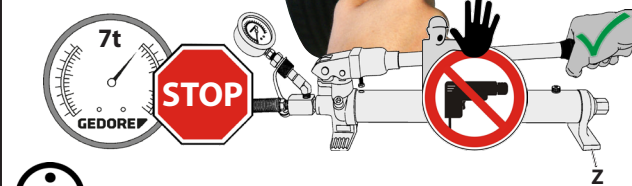

**i** The maximum stroke of the hydraulic cylinder [Y] is 45 mm!  
As soon as it is reached:  
Interrupt the forcing procedure, relieve the pressure from the hydraulic pump [Z] re-tighten the quick clamping nut [W] until the thrust piece [C] is fully applied, and continue the pressing procedure.

**📸 12:** Relieve the pulling device and turn over the positioning plate [D].



**📸 13:** Force in the double silent block in the 2nd step.

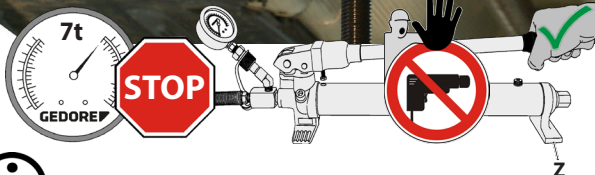

**i** The maximum stroke of the hydraulic cylinder [Y] is 45 mm!  
**As soon as it is reached:**  
Interrupt the forcing procedure, relieve the pressure from the hydraulic pump [Z] re-tighten the quick clamping nut [W] until the thrust piece [C] is fully applied, and continue the pressing procedure.

**8.** First relieve the load on the pulling device. Then remove the clamping device [G] and the clamping bracket [H] on the unit carrier.

**CAUTION**

The double silent block can be damaged when it is completely forced in.

▶ To completely force in the double silent block, the positioning plate [D] **must be** placed in the correct position (with the flat side facing downwards).

**9.** Loosen the collar nut [A], turn the position plate [D], and screw the collar nut [A] clockwise flush on top of the pulling spindle [W] as in **📸 12**.

EN

**⚠ WARNING**

When forcing in the double silent block, the pulling spindle can break, causing various parts to fly around. This can cause **DEATH** or **SEVERE INJURIES**.

▶ **Never** exceed the **maximum load of 7t!**

▶ **Constantly** watch the pressure on the pressure gauge at the hydraulic pump [Z] while forcing off.

▶ While forcing out, **never** stand in the axial extension of the pull spindle [W].

**10.** While operating the hydraulic pump [Z], watch the pressure on the pressure gauge, and, as second step, install the double silent block on the unit carrier completely according to the manufacturer's specifications **📸 13**.

**11.** Relieve and disassemble the pulling device, check the position of the double silent block, and reassemble the vehicle according to the manufacturer's instructions.

**5. CARE / STORAGE**

**CAUTION**

Improper care and storage can damage the pulling device. Therefore, **never** immerse the pulling device in water, solvents, or other cleaning liquids. After use, clean all parts **only** with a dry and clean cleaning cloth. To protect against corrosion, rub all metal parts with a tool care oil or wax. Store the pull device and the operating instructions at a dry and clean place.



## KL-0214-220 A - Double silent block tool VW-Audi, mechanical drive

KL-0214-221

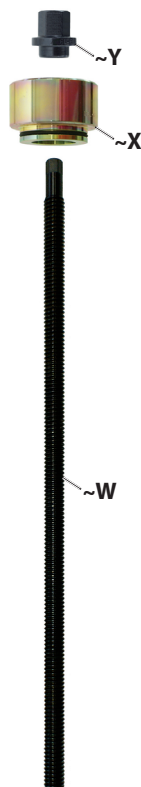
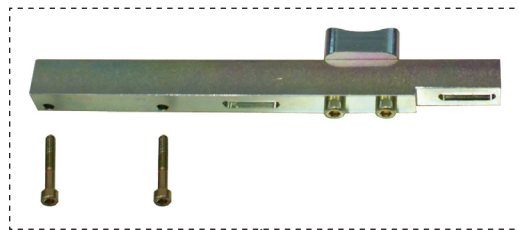
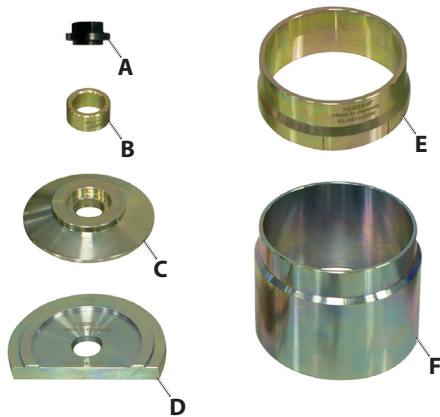

## 6. REPAIR

### ⚠ WARNING

If damage to the pulling device is detected, do no longer use it for safety reasons! Professional inspection and repair may only be carried out by specially trained experts from **GEDORE Automotive GmbH**. Improper repair can result in **DEATH** or **SEVERE INJURIES**.

## 7. OTHER TOOLKITS

### KL-0214-220 A - Double silent block tool VW-Audi, mechanical drive

① As **KL-0214-221**, but including mechanical drive parts.

Item	Part no.	Description	Qty.
-	<b>KL-0214-221</b>	<b>Double silent block tool VW-Audi</b>	<b>1</b>
A	KL-0039-1912-3	Hex collar nut M12, flat	1
B	KL-0214-2202	Spacer ring, Ø 30mm	1
C	KL-0214-2201	Thrust piece, Ø 89.5mm	1
D	KL-0214-2203 A	Position plate	1
E	KL-0214-2204	Conical sleeve, Ø 90mm	1
F	KL-0214-2205	Support sleeve, Ø 92.7mm	1
G	KL-0214-2207	Clamping device	1
H	KL-0214-2206	Clamping bracket with screw	1
I	KL-0214-2208	Set of plastic wedges	1
~Y	KL-0039-1912-2	Collar nut M12	1
~X	KL-0039-1011	Adapter	1
~W	KL-0039-2012-2	Draw spindle M12	1

~ To be used in a similar way as hydraulic drive parts.

## 8. ENVIRONMENTALLY COMPLIANT DISPOSAL

Dispose of the pulling device and its packaging material in an environmentally compatible way in accordance with the legal requirements. If necessary, ask your local authorities about environmentally friendly disposal options.