

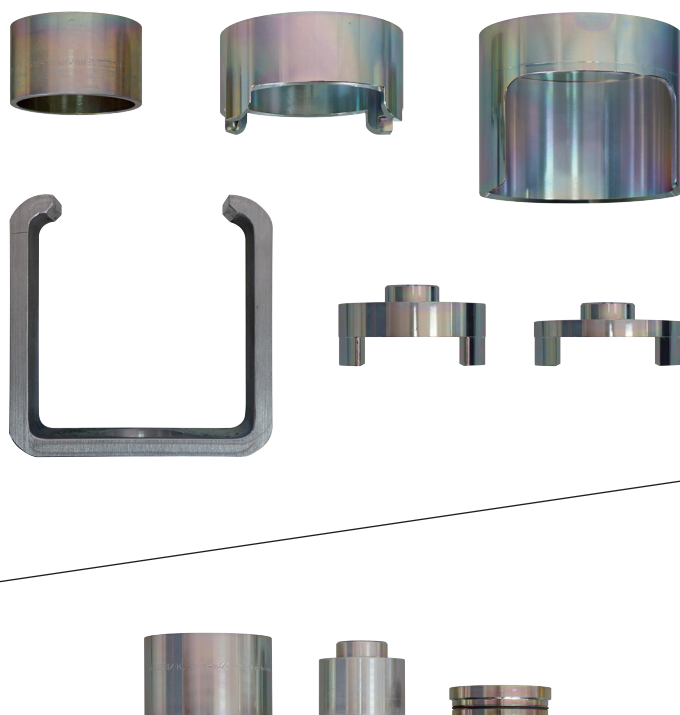

KL-0356-141 // -142 Sleeve Kit (W204)



Operating instructions EN
 Read and understand before use!

www.gedore-automotive.com



GEDORE Automotive GmbH

Breslauer Straße 41
 78166 - Donaueschingen
 Postfach 1329
 78154 Donaueschingen - GERMANY

☎ +49 (0) 771 / 8 32 23-0
 ☎ +49 (0) 771 / 8 32 23-90
 ✉ info.gam@gedore.com
 🌐 gedore-automotive.com

GEDORE TOOLS, INC.

Only for USA, Canada & Mexico / Sólo para EE.UU., Canadá y México
 Seulement pour les USA, le Canada et le Mexique
 7187 Bryhawke Circle, Suite 700
 North Charleston, SC 29418, USA

☎ +1-843 / 225 50 15
 ☎ +1-843 / 225 50 20
 ✉ info@gedoretools.com
 🌐 gedore.com

Version 04/2022

0356-141_-142e190910.indd



ENGLISH

EN

Manufacturer's address

GEDORE Automotive GmbH

Breslauer Straße 41 // 78166 Donaueschingen - GERMANY

☎ +49 (0)771/83223-71 // ✉ info.gam@gedore.com

Imprint

In the course of improvement and adaptation to the state of the art, we reserve the right to make changes with regard to appearance, dimensions, weights and properties, and performance.

This does not imply any claim to correction or subsequent delivery of already delivered products. Deletions can be made at any time without any legal claim arising.

Instructions for use and safety are not binding. They never substitute for any legal or trade association regulations.

We do not accept any liability for printing errors.

Any reproduction, in whole or in part, requires the prior written consent of **GEDORE Automotive GmbH**.

All rights reserved worldwide. © Copyright by **GEDORE Automotive GmbH**, Donaueschingen (GERMANY)

We refer to our general terms and conditions which
can be found in the imprint at:

www.gedore-automotive.com



Contents

1. Basic safety instructions	4
1.1 Target group	4
1.2 Intended use	4
1.3 Misuse/abuse.....	4
1.4 Personal protective equipment.....	4
1.5 Handling	4
1.6 Basic warnings	5
1.7 Work environment	5
1.8 Emissions	5
1.9 Malfunctions.....	5
2. Product description	6
2.1 KL-0356-141 - Sleeve kit (W204) / (Scope of delivery + specifications).....	6
2.2 KL-0356-142 - Supplementary kit rear axle beam (W204) / (scope of delivery + specifications).....	7
2.3 KL-0039-1674 - Thrust sleeve + KL-0039-1786 - Support sleeve / (scope of delivery + specifications).....	7
2.4 Silent block overview	8
3. Preparations	9
3.1 Checking the scope of delivery	9
3.2 Necessary drive parts	9
3.3 Preparing the vehicle	9
4. Typical example of application	10
4.1 Removal and installation of silent block A	10
4.2 Removal and installation of silent block B	12
4.3 Removal and installation of silent block C	14
4.4 Removal and installation of silent block D	16
5. Care and storage	18
6. Maintenance and repair by the GEDORE Automotive Service Center	18
7. Environmentally compatible disposal	18

1. Basic safety instructions

⚠ WARNING

Read and understand the operating instructions before you start using the silent block tool. Misuse can result in **death** or **severe injuries**.

The operating instructions are a part of the silent block tool. Keep these operating instructions at a safe place for future reference, and always pass them on to subsequent users of the silent block tool.

1.1 Target group

These operating instructions are intended to be used by skilled personnel in motor vehicle workshops.

Never allow unauthorised persons or minors to use the silent block tool.

The purchaser of silent block tool **must** ensure that the user has read and understood the operating instructions completely before he uses the silent block tool.

The operating instructions **must** be available at all times to the user of the silent block tool.

1.2 Intended use

The silent block tool is **only used** for removing and fitting the silent blocks on the rear axle beam on a Mercedes C-Class (W204), for example.

The silent block tool may only be used by skilled personnel in motor vehicle workshops.

The silent block tool **may only be used** as described in the operating instructions.

The silent block tool **may only** be actuated with suitable drive components and/or a hydraulic cylinder/pump combination which ensure safe operation!

- Any other use can result in **death** or **severe injuries**.

1.3 Misuse/abuse

Never subject the silent block tool to technical modifications or additions or conversions which could have even the slightest effect on safety!

The silent block tool set **must never** be operated with impermissible and risky drive components!

- **Always** read and observe **all** warnings, safety instructions and other instructions for the operation and maintenance of the silent block tool!
- The silent block tool **may only** be used in a way as described in **Chapter 1.2 - Intended use**. Any other use can result in **death** or **severe injuries**!

1.4 Personal protective equipment

Always wear personal protective equipment when using the silent block tool. The silent block tool can bring about mechanical hazards, such as crushing, cutting, and shock injuries.



Wear EYE PROTECTORS (see OSHA 29 CFR 1910.133 and ANSI Z87) when using the silent block tool to protect the eyes against flinging objects.

- Particles can be thrown up when working with the silent block tool and cause severe injuries to your eyes.



Wear PROTECTIVE GLOVES when using the silent block tool.

- Working with the silent block tool can cause skin abrasions and crushing.



SAFETY SHOES with anti-slip sole and steel toe cap (see OSHA 29 CFR 1910.136 and ANSI Z41) **must** be worn when using the silent block tool.

- Dropping parts can cause injuries to feet and toes.

1.5 Handling



⚠ CAUTION

Observe the following safety precautions to avoid injuries and material damage as a result of misuse and unsafe handling of the silent block tool. **Misuse can result in severe or fatal injuries**.

- Before using the silent block tool, it is **essential** to observe the **basic warnings** given in **Chapter 1.6**!
- The silent block tool must be checked for faultless and safe condition **before each use**. Replace defective or worn parts before use!
- Use **only genuine GEDORE Automotive** spare parts and accessories for the silent block tool!

1.6 Basic warnings

For better differentiation, warnings in these operating instructions are classified as follows:

Warning sign	Signal word	Meaning
	WARNING	Indicates a hazardous situation which, if not avoided, could cause severe or even fatal injuries .
	CAUTION	Indicates a hazardous situation which, if not avoided, could cause moderate or minor injuries .
	CAUTION	Indicates a situation which, if not avoided, can cause damage to the tool, its functions, or an object in its vicinity.
	Note / tip	Note on important information and useful tips for use.

WARNING

Using unsuitable driving components can cause **severe or fatal injuries**.

- The silent block tool may only be actuated with suitable drive components and/or hydraulic cylinder/pump combinations which ensure safe operation!

When removing silent block tools, there is a risk of the silent block tool breaking and parts flying about. This can result in **severe or fatal injuries**.

- Do not exceed the silent block tool's maximum loading capacity of **7t!**
- Ensure that work on vehicles is carried out always in compliance with the instructions and safety regulations of the vehicle manufacturer.
- Wear personal protective equipment (safety goggles, protective gloves, safety shoes).
- Use **only genuine GEDORE Automotive** spare parts and accessories.
- Do not stand in the axial extension of the silent block tool.

A dropping silent block tool can cause **severe injuries**.

- Secure the silent block tool against dropping, for example by using the safety retaining belt - **KL-0040-2590** or **KL-0040-2592** (*accessories / see catalogue*).

CAUTION

Risk of damaging the silent block tool and the vehicle.

- When using the silent block tool, lubricate the pulling spindles **only** with molybdenum disulphide paste, for example **KL-0014-0030** (*accessories / see catalogue*).
- Only the data and instructions issued by the vehicle manufacturer apply for any work on the vehicle.

1.7 Work environment

Safe work with the silent block tool is only possible when the working environment is safe.

- The workplace **must** be clean and tidy.
- The workplace **must** be sufficiently large and protected.
- The workplace **must** be on a solid non-skidding floor.

1.8 Emissions

Molybdenum disulphide paste and hydraulic oil can drip and/or leak when using the silent block tool and thus pose a hazard to the environment.

- Collect escaping hazardous substances immediately in a suitable container and/or remove it with a cleaning cloth or binding agent, and dispose of in an environmentally friendly manner.

1.9 Malfunctions

Maintenance and repairs on the silent block tool **may only be** carried out when the system is depressurised!

Type of the malfunction: Hydraulic oil can escape at the coupling of the hydraulic cylinder.

Measure: If necessary, clean the hydraulic coupling, retighten and/or engage it correctly.

2. Product description

2.1 KL-0356-141 - Sleeve kit (W204)

Fits for the front and rear silent blocks on the rear axle beam, for example on Mercedes C-Class (W204, S204, C204 [to chassis number A116835], X204), E-Class (W212, S212) + (C207), CLS (W218), SL (R231 [front silent block only]).

Alternative tools: W 204 589 00 43 00, W 205 589 00 43 00

The sleeve kit enables, in combination with the required drive parts, a quick removal and installation of the front and rear silent blocks on the rear axle beam, directly on the vehicle. The rear axle beam is only lowered slightly for this purpose; time-consuming removal of the rear axle beam is not necessary.

EN



Scope of delivery/spare parts:

KL-0356-141 - Sleeve kit (W204)			
Item	Part no.	Description	Qty
1	KL-0356-1412	Thrust piece Ø 87mm	1
2	KL-0356-1414	Thrust piece Ø 80mm	1
3	KL-0356-1415	Counter holding tool 93mm	1
4	KL-0356-1413	Support sleeve Ø 105 / 85mm	1
5	KL-0356-1411	Thrust piece Ø 99mm	1
6	KL-0039-1674	Thrust sleeve, short, Ø 74 / 66mm	1

Specifications:

Max. load: 7t

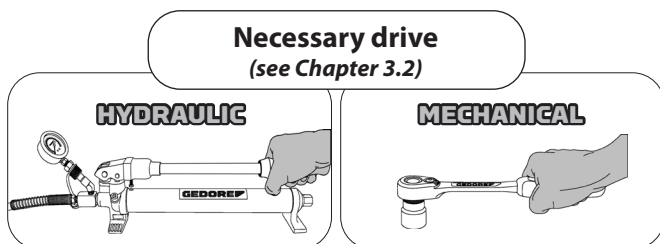

2.2 KL-0356-142 - Supplementary kit rear axle beam (W204)

Suitable for the lower suspension arm silent bearings on the rear axle beam, for example on Mercedes C-Class (W204, S204, C204, X204), E-Class (W212, S212) + (C207), CLS (W218), SL (R231).

Alternative tools: W 204 589 04 43 00, W 220 589 01 43 00

The supplementary kit, in conjunction with the press frame - **KL-0326-1000** as well as the required drive parts, enables the lower spring control arm silent block on the rear axle beam to be quickly removed and installed directly on the vehicle. A time-consuming removal of the rear axle beam is not necessary.

When dismantling the suspension link, the fastening screw, which is directly in the silent block, breaks off very often, so that the removal with a pull spindle is no longer possible.

Together with the thrust spindle, the special press frame - **KL-0326-1000**, which is used when removing the silent block, makes the use of a pull spindle unnecessary.

Note: Alternatively, it is also possible to remove the silent block **without** the press frame - **KL-0326-1000**. However, the hole on the silent block must be continuous, and the support sleeve - **KL-0039-1772** (accessory) is also required.

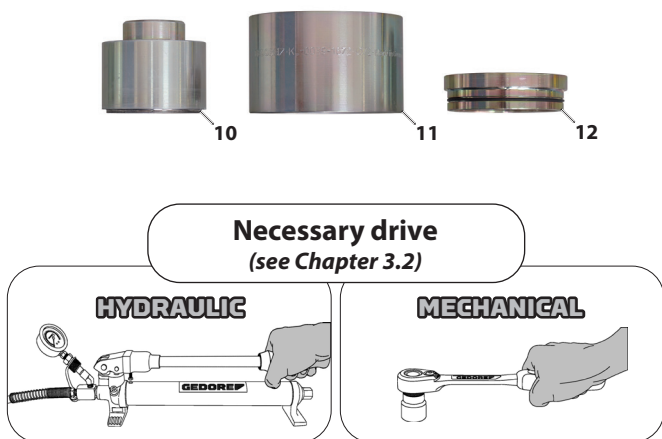

Scope of delivery/spare parts:

KL-0356-142 - Supplementary kit rear axle beam (W204)			
Item	Part no.	Description	Qty
10	KL-0356-1421	Thrust sleeve, short, Ø 50 / 42mm	1
11	KL-0039-1672	Support sleeve, Ø 72 / 64mm	1
12	KL-0326-1111	Adapter ring 1 with O-ring	1

Specifications:

Max. load: 7t

2.3 KL-0039-1674 - Thrust sleeve + KL-0039-1786 - Support sleeve

Suitable for the differential silent bearings on the rear axle beam, for example on Mercedes C-Class (W204, S204, C204, X204), E-Class (W212, S212) + (C207), CLS (W218), SL (R231).

The thrust and support sleeves, in combination with the required drive parts, enable quick removal and installation of the differential silent block on the rear axle beam directly on the vehicle. A time-consuming removal of the rear axle beam is not necessary.

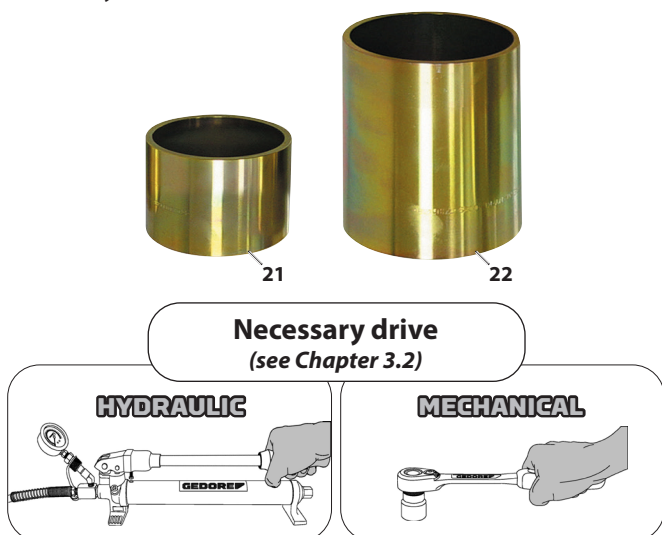

Scope of delivery/spare parts:

KL-0039-1674 - Thrust sleeve + KL-0039-1786 - Support sleeve			
Item	Part no.	Description	Qty
21	KL-0039-1674	Pressure sleeve, short Ø 74 / Ø 66	1
22	KL-0039-1786	Support sleeve, long Ø 86 / Ø 78	1

Specifications:

Max. load: 7t

2.4 Silent block overview:

Depending on the silent block on the rear axle beam, assemble the required basic tool + drive parts accordingly.

Silent block A

Rear silent block on rear axle beam
(A 204 350 01 75)



Required tools:
KL-0356-141 - Sleeve kit (W204)
+ required drive parts

Silent block C

Silent block differential gear
(A 204 351 04 42)



Required tools:
KL-0039-1674 - Thrust sleeve
KL-0039-1786 - Support sleeve
+ required drive parts

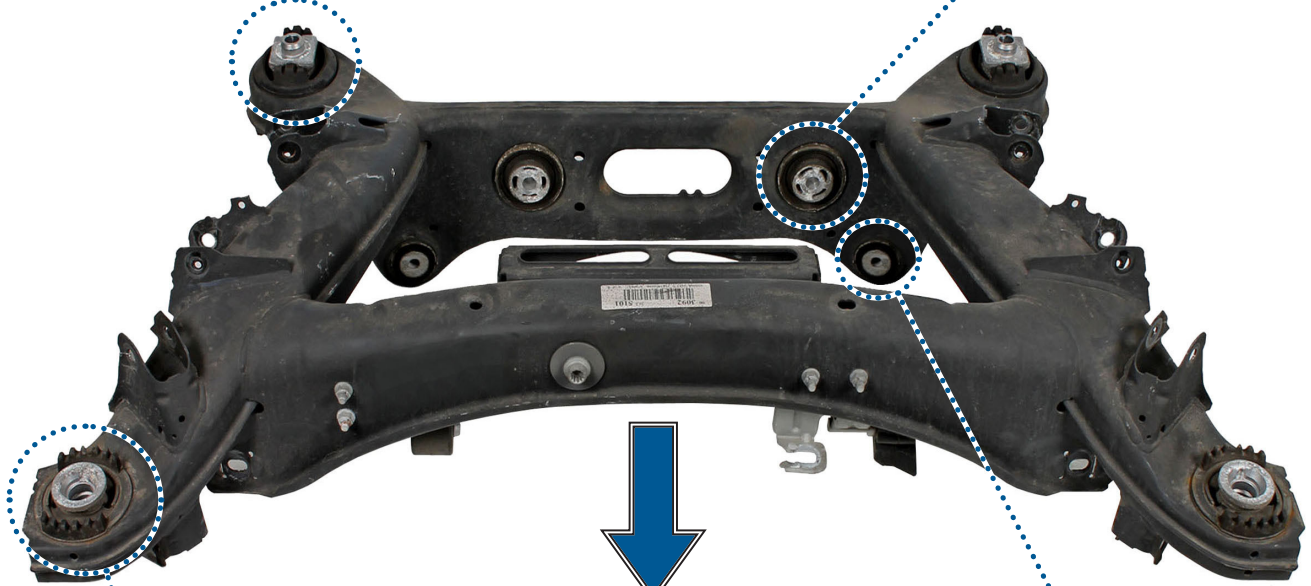

Direction of travel



Required tools:
KL-0356-141 - Sleeve kit (W204)
+ required drive parts

Required tools:
KL-0356-142 - Supplementary
kit for rear axle beam (W204)
+ KL-0326-1000 - Press frame
+ required drive parts

alternatively:
KL-0356-142 - Supplementary
kit for rear axle beam (W204)
+ KL-0039-1772 - Support
sleeve + required drive parts



Silent block D

Silent block spring link
control arm
(A 204 352 10 65)

Silent block B

Front silent block on rear axle beam
(A 204 351 08 42)

Fig. 1: Required drive parts

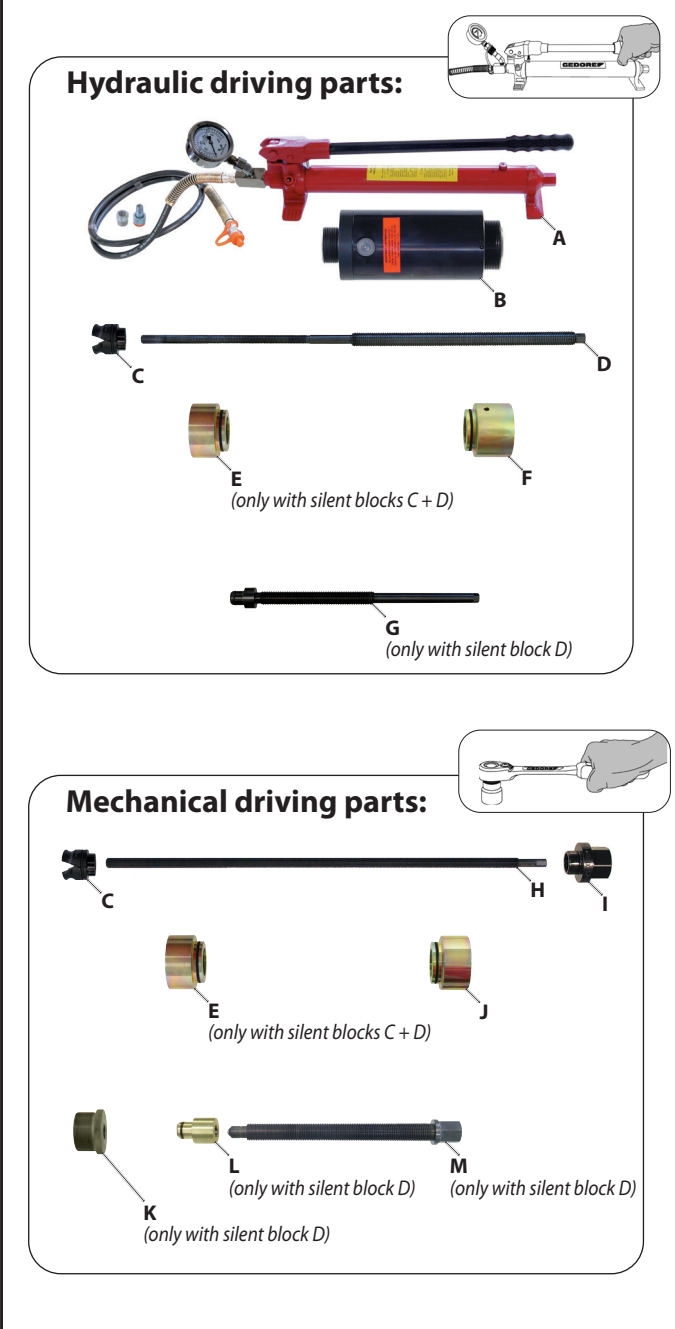
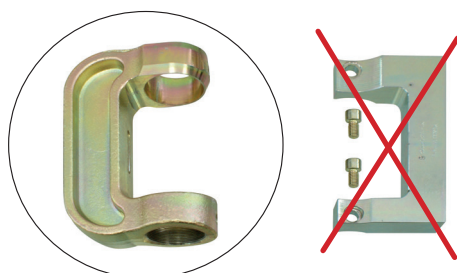

Fig. 2: Press frame - KL-0326-1000 required when changing the **silent block D**



3. Preparations

Prior to using the silent block tool first time, check and ensure that all parts of the scope of delivery are available. Follow the instructions below.

3.1 Checking the scope of delivery

3.2 Required drive parts (see fig. 1)

⚠ WARNING

Using unsuitable driving components can cause **severe or fatal injuries**.

- The silent block tool **may only** be actuated with suitable drive components and/or hydraulic cylinder/pump combinations which ensure safe operation!

Depending on which silent block is to be changed on the rear axle beam, assemble the required basic tool and the corresponding drive parts. (See page 8 / chapter 2.4 - silent block overview)

(Hydraulic) driving parts:

Item	Part no.	Description
A	KL-0040-35 M25	Hydraulic pump with 17t manometer
B	KL-0040-2500	Hydraulic cylinder 17t
C	KL-0039-2112-2	Quick-release nut M12
D	KL-0039-1912-1	Draw spindle M12
E	KL-0039-1002	Adapter for clamping nut
F	KL-0039-1003	Retaining adapter for hydraulic cylinder
G	KL-0039-1930	Thrust spindle M20 x 590mm

(Mechanical) driving parts:

Item	Part no.	Description
C	KL-0039-2112-2	Quick-release nut M12
E	KL-0039-1002	Adapter for clamping nut
H	KL-0039-2012-1	Draw spindle M12
I	KL-0039-1912-2	Collar nut M12
J	KL-0039-1011	Mounting adapter for mechanical spindle
K	KL-0174-547	Adapter 2 1/4"-14 UNS to M20x2
L	KL-0174-853	Thrust piece for mechanical spindle
M	KL-0174-620	Spindle M20 x 230mm

Note:

When changing the spring control arm **silent block D**, the press frame - **KL-0326-1000**, available as an *accessory*, is also required! (See Fig. 2)

3.3 Preparing the vehicle

Loosen and/or remove all necessary parts according to manufacturer's instructions (remove wheels, loosen rear axle beam, and lower slightly using gear unit jack, for example).

Fig. 3: Apply the pulling device to the **silent block A**.

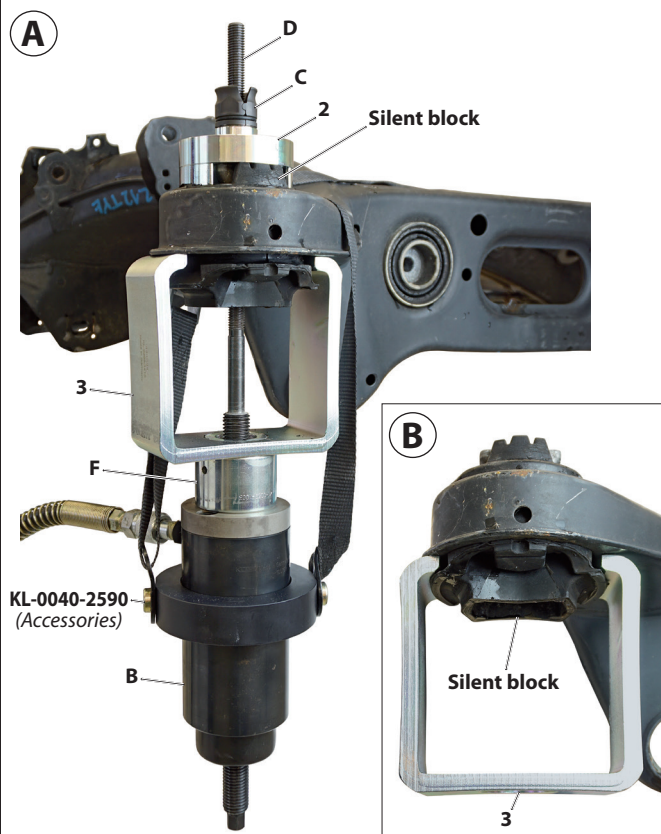
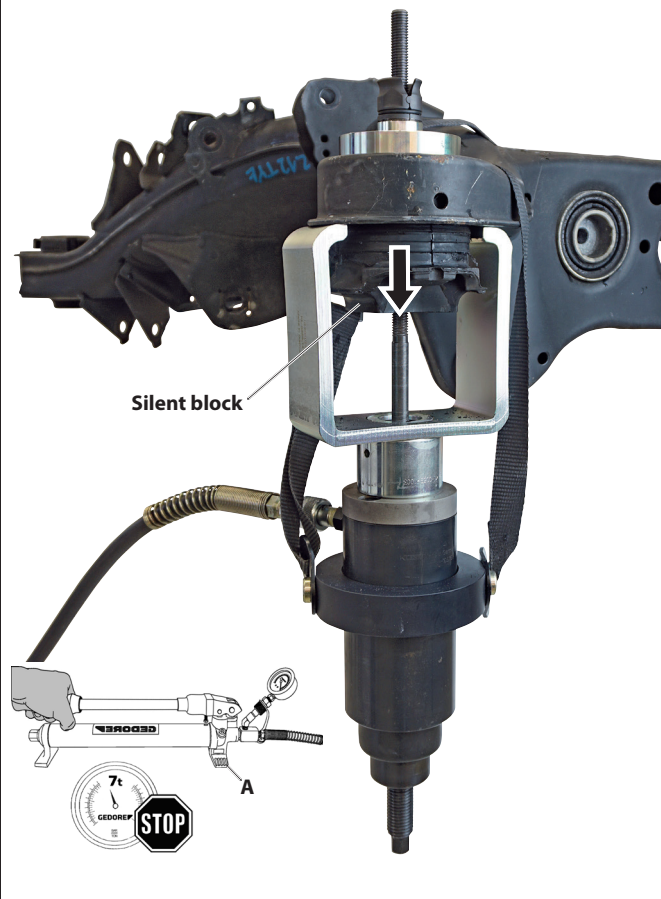

Fig. 4: Pull the **silent block A** from the rear axle beam.



4. Typical application

- See chapter 4.1** - Removal and installation of **silent block A**
- See chapter 4.2** - Removal and installation of **silent block B**
- See chapter 4.3** - Removal and installation of **silent block C**
- See chapter 4.4** - Removal and installation of **silent block D**

4.1 Removal and installation of **silent block A**

This typical application describes the **hydraulic** pulling of the **rear silent block (silent block A)** from the rear axle beam of a Mercedes C-Class (W204).

(**Mechanical** pulling follows the same principle)

CAUTION

- The silent block tool and the rear axle beam can be damaged.
- Make sure that the thrust piece "2" and the counter support "3" are in the correct position and level!
 - The thrust piece "2" must engage completely over the silent block.
 - The counter support "3" must rest flat over the silent block on the rear axle beam. (Fig. 3 B)

1. Apply the silent block tool to the rear **silent block A** as shown in Fig. 3 A + B.

Note:

The safety retaining belt **KL-0040-2590**, which is available as an accessory, permits the wheel hub extractor to be secured to the vehicle and thus preventing it from dropping.

⚠ WARNING

Using unsuitable driving components can cause **severe or fatal injuries**.

- The silent block tool **may only** be actuated with suitable drive components and/or hydraulic cylinder/pump combinations which ensure safe operation!

2. Connect hydraulic pump "A" to hydraulic cylinder "B".

⚠ WARNING

When removing silent blocks, there is a risk of the silent block tool breaking and parts flying about. This can result in **severe or fatal injuries**.

- Do not exceed the silent block tool's maximum loading capacity of **7t!**
- Wear personal protective equipment (safety goggles, protective gloves, safety shoes).
- Do not stand in the axial extension of the silent block tool. A dropping silent block tool can cause **severe injuries**.
- Secure the silent block tool against dropping, for example by using the safety retaining belt - **KL-0040-2590** or **KL-0040-2592** (accessories / see catalogue).

3. Operate the hydraulic pump "A" and pull the rear **silent block A** from the rear axle beam. During the removal procedure, watch the required force on the pressure gauge of hydraulic pump "A"! (Fig. 4)

Fig. 5: Place the silent block tool together with **silent block A** on the rear axle beam.

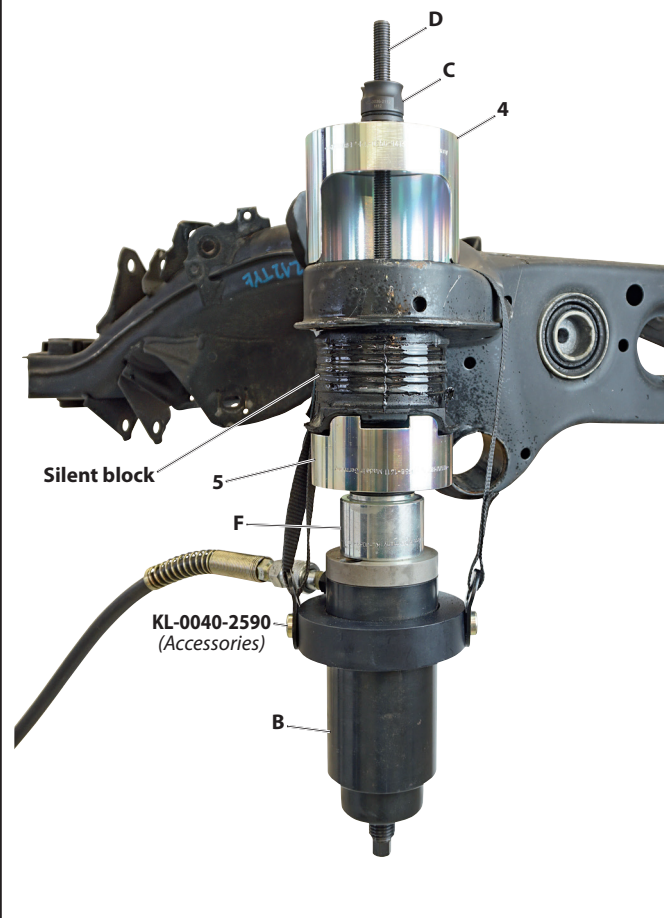
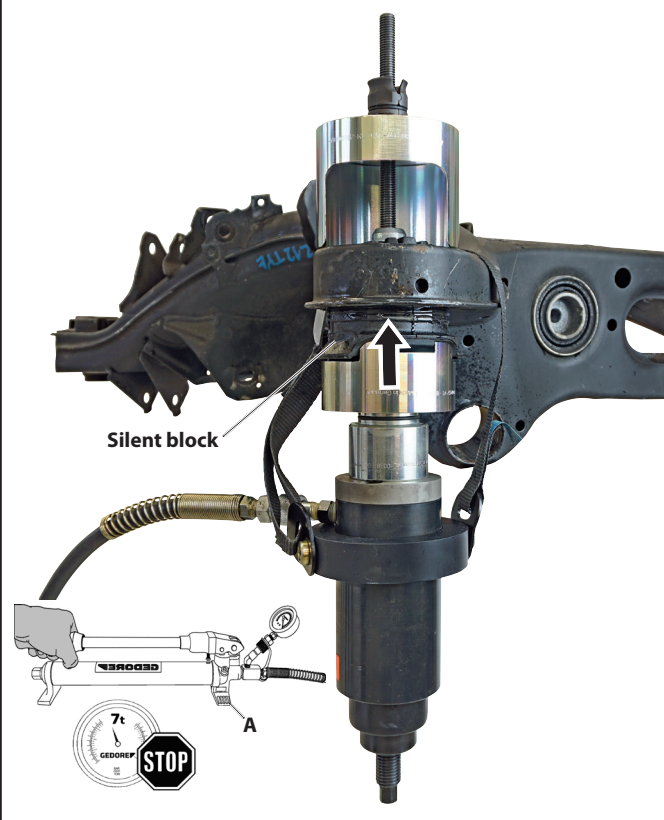

Fig. 6: Push the **silent block A** into the rear axle beam.



- Relieve the hydraulic cylinder "B" with the hydraulic pump "A" and remove the silent block tool from the rear **silent block A**.

CAUTION

The silent block tool, the silent block, and the rear axle beam can be damaged.

- Clean the silent block mount and, if necessary, coat it and the silent block with a suitable lubricant.
- Place the silent block in the correct position on the rear axle carrier according to the manufacturer's specifications.
- Ensure a correct and even seat of the support sleeve "4" and the thrust piece "5"!
- The support sleeve "4" must rest flat on the rear axle beam and be centred on the silent block hole.
- The thrust piece "5" must engage completely over the silent block.

- Place the silent block tool, as shown in **Fig. 5**, together with the (new) rear **silent block A** in the correct position on the rear axle beam according to the manufacturer's specifications.

Note:

The safety retaining belt **KL-0040-2590**, which is available as an accessory, permits the wheel hub extractor to be secured to the vehicle and thus preventing it from dropping.

WARNING

When installing silent blocks, there is a risk of the silent block tool breaking and parts flying about. This can result in **severe or fatal injuries**.

- Do not exceed the silent block tool's maximum loading capacity of **7t!**
 - Wear personal protective equipment (safety goggles, protective gloves, safety shoes).
 - Do not stand in the axial extension of the silent block tool.
- A dropping silent block tool can cause **severe injuries**.
- Secure the silent block tool against dropping, for example by using the safety retaining belt - **KL-0040-2590** or **KL-0040-2592** (accessories / see catalogue).

- Operate the hydraulic pump "A" and pull the rear **silent block A** into the rear axle beam according to the manufacturer's specifications. During the installation procedure, watch the required force on the pressure gauge of hydraulic pump "A"! (**Fig. 6**)

- Relieve hydraulic cylinder "B" with the hydraulic pump "A" and remove the silent block tool from the vehicle. Perform further maintenance work on the vehicle as specified by the manufacturer.

Fig. 7: Apply the silent block tool to the **silent block B**.

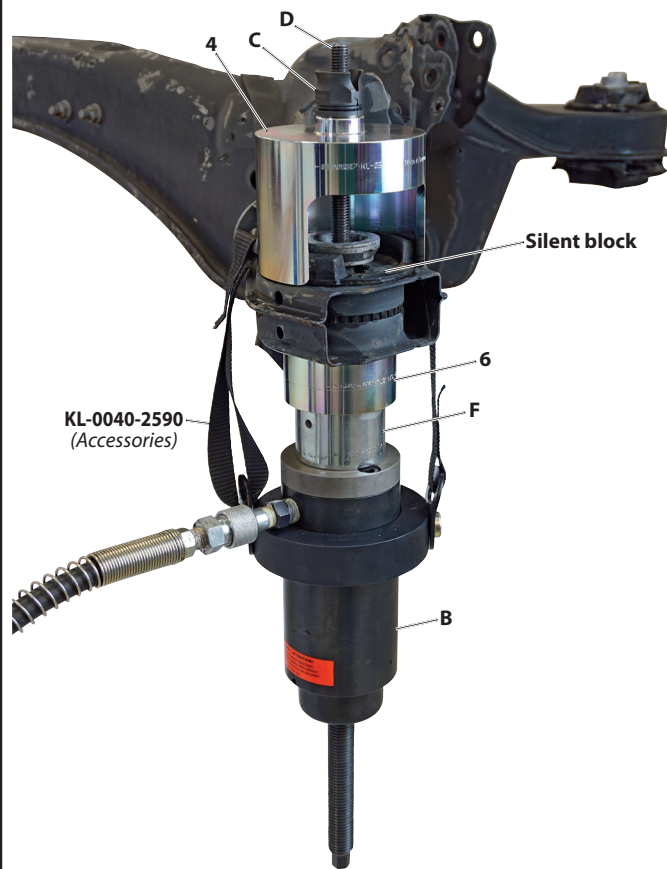
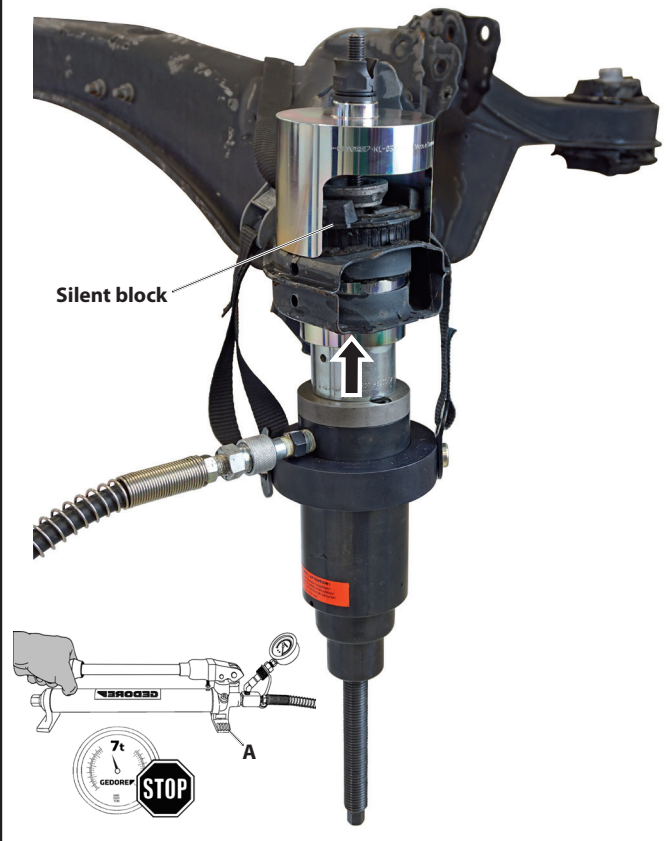

Fig. 8: Pull the **silent block B** from the rear axle beam.



4.2 Removal and installation of **silent block B**

This typical application describes the **hydraulic** extraction of the **front silent block (silent block B)** on the rear axle beam of a Mercedes C-Class (W204).

(The **mechanical** extraction follows the same principle)

CAUTION

The silent block tool and the rear axle carrier can be damaged.

- Ensure that the support sleeve "4" and the thrust sleeve "6" are seated evenly and correctly!
- The support sleeve "4" must rest flat on the rear axle beam and be centred on the silent block hole.
- The thrust sleeve "6" must be centred on the silent block.

1. Place the silent block tool on the front **silent block B** as shown in **fig. 7**.

Note:

The safety retaining belt **KL-0040-2590**, which is available as an *accessory*, permits the wheel hub extractor to be secured to the vehicle and thus preventing it from dropping.

⚠ WARNING

Using unsuitable driving components can cause **severe or fatal injuries**.

- The silent block tool **may only** be actuated with suitable drive components and/or hydraulic cylinder/pump combinations which ensure safe operation!

2. Connect hydraulic pump "A" to hydraulic cylinder "B".

⚠ WARNING

When removing silent blocks, there is a risk of the silent block tool breaking and parts flying about. This can result in **severe or fatal injuries**.

- Do not exceed the silent block tool's maximum loading capacity of **7t!**
- Wear personal protective equipment (safety goggles, protective gloves, safety shoes).
- Do not stand in the axial extension of the silent block tool.

A dropping silent block tool can cause **severe injuries**.

- Secure the silent block tool against dropping, for example by using the safety retaining belt - **KL-0040-2590** or **KL-0040-2592** (accessories / see catalogue).

3. Operate the hydraulic pump "A" and pull the front **silent block B** from the rear axle beam. During the removal procedure, watch the required force on the pressure gauge of hydraulic pump "A"! (**Fig. 8**)

Fig. 9: Place the silent block tool together with **silent block B** on the rear axle beam.

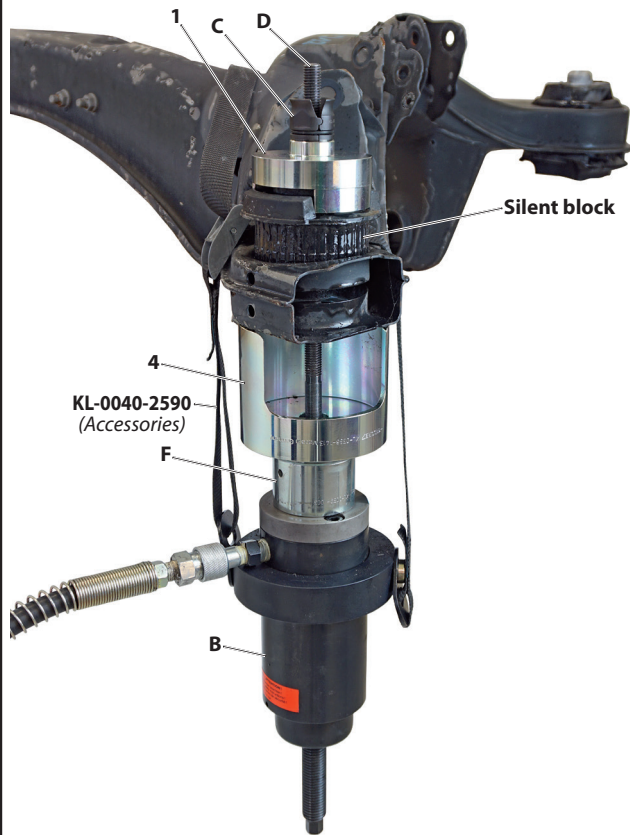
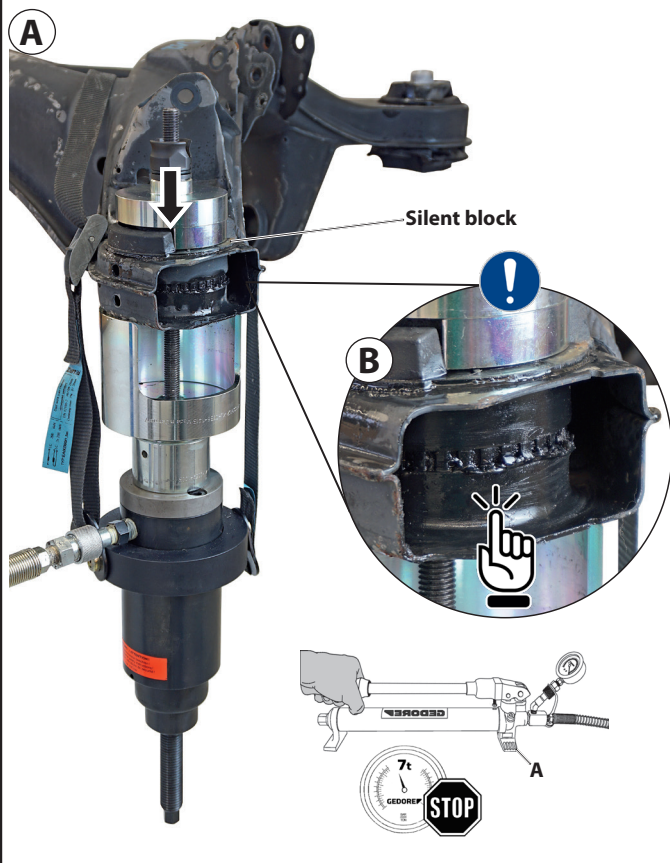

Fig. 10: Push the **silent block B** on the rear axle beam.



- Relieve hydraulic cylinder "B" with the hydraulic pump "A" and take off the silent block tool from the front **silent block B**.

CAUTION

The silent block tool, the silent block, and the rear axle beam can be damaged.

- Clean the silent block mount and, if necessary, coat it and the silent block with a suitable lubricant.
- Place the silent block in the correct position on the rear axle carrier according to the manufacturer's specifications.
- Ensure a correct and even seat of the support sleeve "4" and the thrust piece "1"!
- The support sleeve "4" must rest flat on the rear axle beam and be centred on the silent block hole.
- The thrust piece "1" must engage completely over the silent block.

- Place the silent block tool, as shown in **Fig. 9**, together with the (new) front **silent block B** in the correct position on the rear axle beam according to the manufacturer's specifications.

Note:

The safety retaining belt **KL-0040-2590**, which is available as an accessory, permits the wheel hub extractor to be secured to the vehicle and thus preventing it from dropping.

⚠ WARNING

When installing silent blocks, there is a risk of the silent block tool breaking and parts flying about. This can result in **severe or fatal injuries**.

- Do not exceed the silent block tool's maximum loading capacity of **7t!**
- Wear personal protective equipment (safety goggles, protective gloves, safety shoes).
- Do not stand in the axial extension of the silent block tool.

A dropping silent block tool can cause **severe injuries**.

- Secure the silent block tool against dropping, for example by using the safety retaining belt - **KL-0040-2590** or **KL-0040-2592** (accessories / see catalogue).

CAUTION

The silent block can be damaged.

- During pressing, make sure that the silent block is not damaged at the narrow opening on the rear axle beam. (**Fig. 10 B**)

- Operate the hydraulic pump "A" and pull the front **silent block B** into the rear axle beam according to the manufacturer's specifications. During the installation procedure, watch the required force on the pressure gauge of hydraulic pump "A"! (**Fig. 10 A + B**)

- Relieve hydraulic cylinder "B" with the hydraulic pump "A" and remove the silent block tool from the vehicle. Perform further maintenance work on the vehicle as specified by the manufacturer.

EN

Fig. 11: Apply the silent block tool to the **silent block C**.

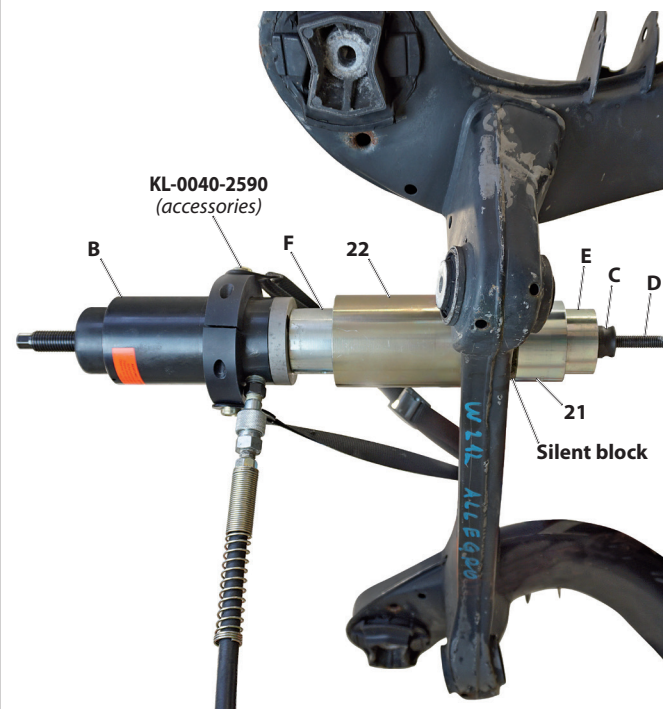

Fig. 12: Pull **silent block C** from the rear axle beam.



4.3 Removal and installation of **silent block C**

This typical application describes the **hydraulic** pulling of the differential **silent block (silent block C)** from the rear axle beam of a Mercedes C-Class (W204).

(**Mechanical** pulling follows the same principle)

CAUTION

The silent block tool and the rear axle beam can be damaged.

- Ensure that the thrust sleeve "21" and the support sleeve "22" are seated evenly and in the correct position!
- The thrust sleeve "21" must be centred on the silent block.
- The support sleeve "22" must rest flat on the rear axle beam and be centred on the silent block hole.

1. Place the silent block tool on the differential **silent block C** as shown in **Fig. 11** .

Note:

The safety retaining belt **KL-0040-2590**, which is available as an *accessory*, permits the wheel hub extractor to be secured to the vehicle and thus preventing it from dropping.

⚠ WARNING

Using unsuitable driving components can cause **severe or fatal injuries**.

- The silent block tool **may only** be actuated with suitable drive components and/or hydraulic cylinder/pump combinations which ensure safe operation!

2. Connect hydraulic pump "A" to hydraulic cylinder "B".

⚠ WARNING

When removing silent blocks, there is a risk of the silent block tool breaking and parts flying about. This can result in **severe or fatal injuries**.

- Do not exceed the silent block tool's maximum loading capacity of **7t!**
- Wear personal protective equipment (safety goggles, protective gloves, safety shoes).
- Do not stand in the axial extension of the silent block tool.

A dropping silent block tool can cause **severe injuries**.

- Secure the silent block tool against dropping, for example by using the safety retaining belt - **KL-0040-2590** or **KL-0040-2592** (accessories / see catalogue).

3. Operate the hydraulic pump "A" and pull the differential **silent block C** from the rear axle beam. During the removal procedure, watch the required force on the pressure gauge of hydraulic pump "A"! (**Fig. 12**)

Fig. 13: Place the silent block tool together with **silent block C** on the rear axle beam.

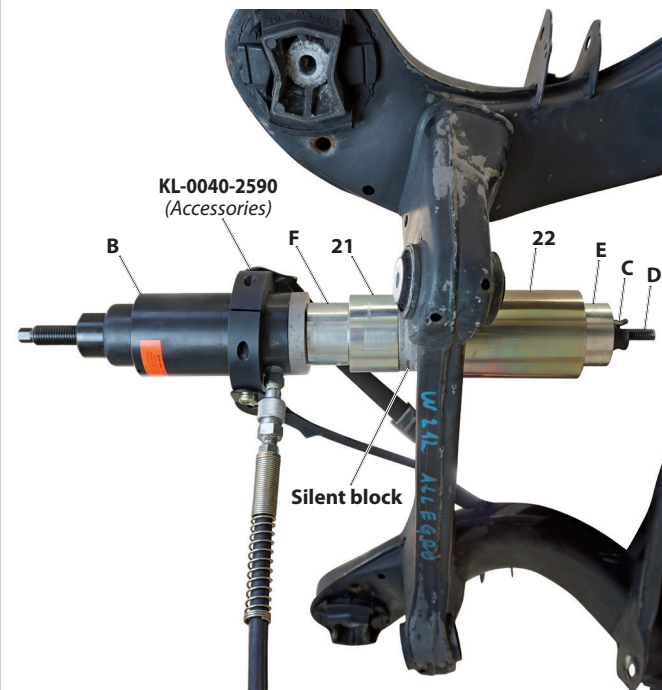
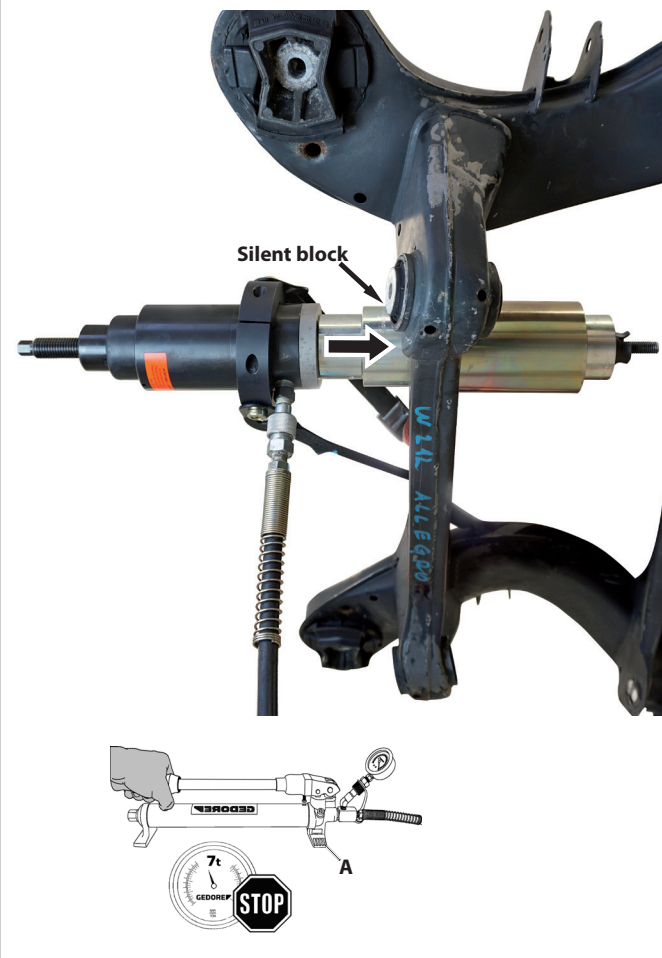

Fig. 14: Push **silent block C** into the rear axle beam.



- Relieve hydraulic cylinder "B" with the hydraulic pump "A" and take off the silent block tool from the rear **silent block C**.

CAUTION

The silent block tool, the silent block, and the rear axle beam can be damaged.

- Clean the silent block mount and, if necessary, coat it and the silent block with a suitable lubricant.
- Place the silent block in the correct position on the rear axle carrier according to the manufacturer's specifications.
- Ensure that the thrust sleeve "21" and the support sleeve "22" are seated correctly and evenly!
- The thrust sleeve "21" must be centred on the silent block.
- The support sleeve "22" must rest flat on the rear axle beam and be centred on the silent block hole.

- Place the silent block tool, as shown in **Fig. 13**, together with the (new)differential **silent block C** in the correct position on the rear axle beam according to the manufacturer's specifications.

Note:

The safety retaining belt **KL-0040-2590**, which is available as an accessory, permits the wheel hub extractor to be secured to the vehicle and thus preventing it from dropping.

⚠ WARNING

When installing silent blocks, there is a risk of the silent block tool breaking and parts flying about. This can result in **severe or fatal injuries**.

- Do not exceed the silent block tool's maximum loading capacity of **7t!**
- Wear personal protective equipment (safety goggles, protective gloves, safety shoes).
- Do not stand in the axial extension of the silent block tool. A dropping silent block tool can cause **severe injuries**.
- Secure the silent block tool against dropping, for example by using the safety retaining belt - **KL-0040-2590** or **KL-0040-2592** (accessories / see catalogue).

- Operate the hydraulic pump "A" and pull the differential **silent block C** into the rear axle beam according to the manufacturer's instructions. During the installation procedure, watch the required force on the pressure gauge of hydraulic pump "A"! (**Fig. 14**)

- Relieve hydraulic cylinder "B" with the hydraulic pump "A" and remove the silent block tool from the vehicle. Perform further maintenance work on the vehicle as specified by the manufacturer.

Fig. 15: Apply the silent block tool to the **silent block D**.

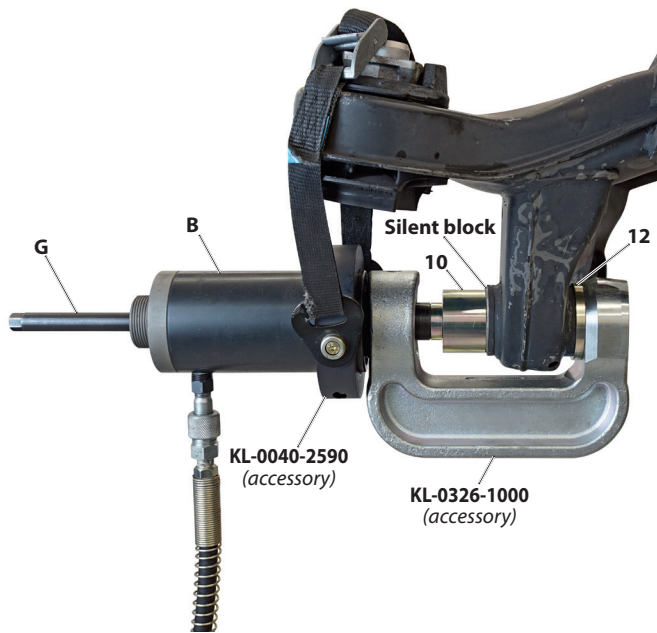
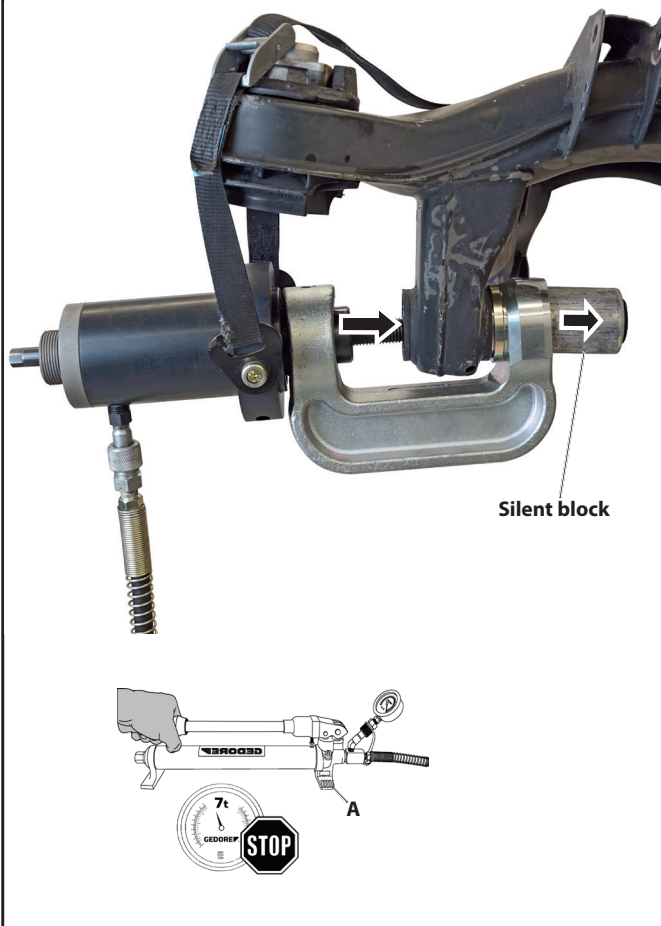

Fig. 16: Removing the silent block D at the rear axle beam.



4.4 Removal and installation of **silent block D**

This application example describes the **hydraulic** pulling of the **spring link control arm silent block (silent block D)** on the rear axle beam of a Mercedes C-Class (W204).

(The **mechanical** extraction follows the same principle)

Removal of silent block D with press frame - KL-0326-1000

CAUTION

The silent block tool and the rear axle beam can be damaged.

- Ensure that the thrust sleeve "10" and the adapter ring "12" are seated correctly and evenly!
- The thrust sleeve "10" must be centred on the silent block.
- The adapter ring "12" must rest flat on the rear axle beam and be centred on the silent block bore.

1. Apply the silent block tool to the spring link **silent block D** as shown in **Fig.15**.

Note:

The safety retaining belt **KL-0040-2590**, which is available as an *accessory*, permits the wheel hub extractor to be secured to the vehicle and thus preventing it from dropping.

⚠ WARNING

Using unsuitable driving components can cause **severe or fatal injuries**.

- The silent block tool **may only** be actuated with suitable drive components and/or hydraulic cylinder/pump combinations which ensure safe operation!

2. Connect hydraulic pump "A" to hydraulic cylinder "B".

⚠ WARNING

When removing silent blocks, there is a risk of the silent block tool breaking and parts flying about. This can result in **severe or fatal injuries**.

- Do not exceed the silent block tool's maximum loading capacity of **7t!**
- Wear personal protective equipment (safety goggles, protective gloves, safety shoes).
- Do not stand in the axial extension of the silent block tool.

A dropping silent block tool can cause **severe injuries**.

- Secure the silent block tool against dropping, for example by using the safety retaining belt - **KL-0040-2590** or **KL-0040-2592** (accessories / see catalogue).

3. Operate the hydraulic pump "A" and pull the spring link **silent block D** from the rear axle beam. During the removal procedure, watch the required force on the pressure gauge of hydraulic pump "A"! (**Fig. 16**)

4. Relieve hydraulic cylinder "B" with the hydraulic pump "A" and take off the silent block tool from the spring link **silent block D**.

Fig. 17: Apply the silent block tool to the **silent block D**.

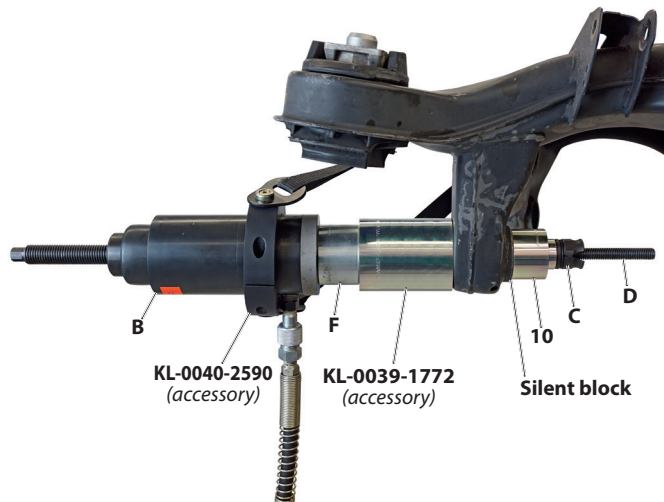
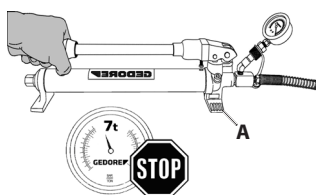

Fig. 18: Pull the **silent block D** on the rear axle beam.



Removal of silent block D

without press frame, as an alternative,
with support sleeve - KL-0039-1772
(accessory)

CAUTION

- The silent block tool and the rear axle carrier can be damaged.
- Ensure that the thrust sleeve "10" and the support sleeve "KL-0039-1772" are seated correctly and evenly!
 - The thrust sleeve "10" must be centred on the silent block.
 - The support sleeve "KL-0039-1772" must rest flat on the rear axle beam and be centred on the silent block bore.

1. Apply the silent block tool to the spring link **silent block D** as shown in **Fig.17**.

Note:

The safety retaining belt **KL-0040-2590**, which is available as an *accessory*, permits the wheel hub extractor to be secured to the vehicle and thus preventing it from dropping.

⚠ WARNING

Using unsuitable driving components can cause **severe or fatal injuries**.

- The silent block tool **may only** be actuated with suitable drive components and/or hydraulic cylinder/pump combinations which ensure safe operation!

2. Connect hydraulic pump "A" to hydraulic cylinder "B".

⚠ WARNING

When removing silent blocks, there is a risk of the silent block tool breaking and parts flying about. This can result in **severe or fatal injuries**.

- Do not exceed the silent block tool's maximum loading capacity of **7t!**
- Wear personal protective equipment (safety goggles, protective gloves, safety shoes).
- Do not stand in the axial extension of the silent block tool.

A dropping silent block tool can cause **severe injuries**.

- Secure the silent block tool against dropping, for example by using the safety retaining belt - **KL-0040-2592** (accessories / see catalogue).

3. Operate the hydraulic pump "A" and pull the spring link **silent block D** out of the rear axle beam. During the removal procedure, watch the required force on the pressure gauge of hydraulic pump "A"! (**Fig. 18**)

4. Relieve hydraulic cylinder "B" with the hydraulic pump "A" and take off the silent block tool from the spring link **silent block D**.

Fig. 19: Place the silent block tool together with **silent block D** on the rear axle beam.

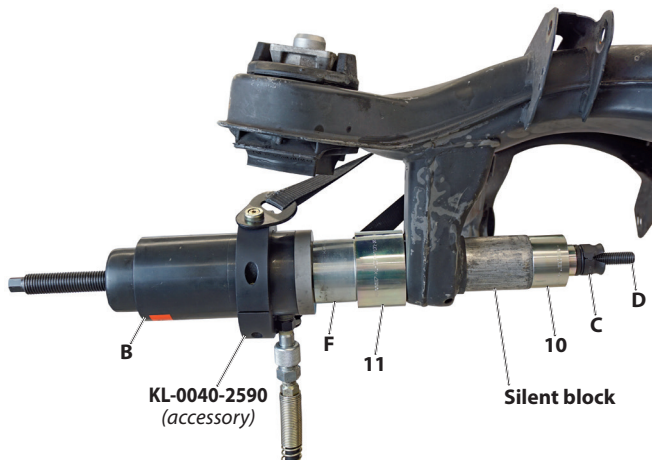
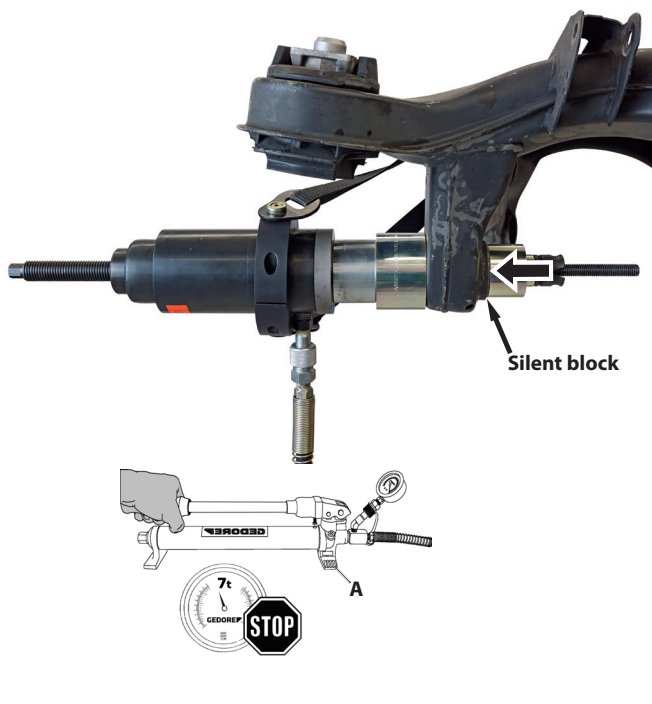

Fig. 20: Insert **Silent block D** on the rear axle beam.



Installation silent block D

CAUTION

The silent block tool, the silent block, and the rear axle beam can be damaged.

- Clean the silent block mount and, if necessary, coat it and the silent block with a suitable lubricant.
- Position the silent block correctly on the rear axle beam according to the manufacturer's specifications.
- Ensure that the thrust sleeve "10" and the support sleeve "11" are seated correctly and evenly!
- The thrust sleeve "10" must be centred on the silent block.
- The support sleeve "11" must rest level on the rear axle beam and be centred on the silent block bore.

1. As shown in **Fig. 19**, place the silent block tool together with the (new) spring link **silent block D** in the correct position on the rear axle beam according to the manufacturer's specifications.

Note:

The safety retaining belt **KL-0040-2590**, which is available as an accessory, permits the silent block tool to be secured to the vehicle and thus preventing it from dropping.

⚠ WARNING

When installing silent blocks, there is a risk of the silent block tool breaking and parts flying about. This can result in **severe or fatal injuries**.

- Do not exceed the silent block tool's maximum loading capacity of **7t!**
 - Wear personal protective equipment (safety goggles, protective gloves, safety shoes).
 - Do not stand in the axial extension of the silent block tool.
- A dropping silent block tool can cause **severe injuries**.
- Secure the silent block tool against dropping, for example by using the safety retaining belt - **KL-0040-2590** or **KL-0040-2592** (accessories / see catalogue).

2. Operate the hydraulic pump "A" and retract the spring link **silent block D** into the rear axle beam according to the manufacturer's specifications. During the installation procedure, watch the required force on the pressure gauge of hydraulic pump "A"! (**Fig. 20**)
3. Relieve the hydraulic cylinder "B" with the hydraulic pump "A", and take off the silent block tool from the vehicle. Perform further work on the vehicle as specified by the manufacturer.

5. Care and storage

CAUTION: Benzene and chemical solvents can damage plastic parts.

After each use, clean all parts with a clean cloth only. To protect them against corrosion, lightly rub all metal parts after use with an anti-corrosion oil or wax that is suitable for tool care.

Keep the special tool in a dry and clean place.

6. Maintenance and repair by the GEDORE Automotive Service Center

CAUTION: For safety reasons, ensure that a damaged special tool is no longer used. Only specifically trained personnel are allowed to carry out professional inspection and repair. Improper repair of the special tool can result in **fatal or serious injuries**.

Consequently, please contact GEDORE Automotive GmbH: **GEDORE Automotive GmbH**
Breslauer Str. 41 // 78166 Donaueschingen // Telephone: +49 (0)771/83223-71 // E-mail: info.gam@gedore.com

7. Environmentally compliant disposal

Dispose of special tool and packaging material in accordance with the legal requirements in an environmentally friendly manner.

GEDORE-Werkzeugfabrik GmbH & Co. KG

Remscheider Straße 149
42899 - Remscheid
Postfach 120361
47873 Remscheid
GERMANY

Vertrieb DEUTSCHLAND

☎ +49 (0) 2191 / 596-0
☎ +49 (0) 2191 / 596-230
✉ info@gedore.com
🌐 www.gedore.com

Sales INTERNATIONAL

☎ +49 (0) 2191 / 596-910
☎ +49 (0) 2191 / 596-911
✉ info@gedore.com
🌐 www.gedore.com

GEDORE TOOLS, INC.

Only for USA, Canada & Mexico
Sólo para EE.UU., Canadá y México
Seulement pour les USA, le Canada et le Mexique
7187 Bryhawke Circle, Suite 700, North Charleston, SC 29418, USA

☎ +1-843 / 225 50 15
☎ +1-843 / 225 50 20
✉ info@gedoretools.com
🌐 www.gedoretools.com

Worldwide GEDORE service centers and offices are listed on the Internet at: www.gedore.com

GEDORE Automotive GmbH

Breslauer Straße 41
78166 - Donaueschingen
Postfach 1329
78154 Donaueschingen
GERMANY

Vertrieb DEUTSCHLAND

☎ +49 (0) 771 / 8 32 23-0
☎ +49 (0) 771 / 8 32 23-90
✉ info.gam@gedore.com
🌐 gedore-automotive.com



www.gedore-automotive.com